

智能阀门定位器

1500 系列使用说明书

(安装使用前请仔细阅读使用说明书)



使用说明书目录

1500 系列智能阀门定位器

1. 概述	1
1.1. 产品结构	1
1.2. 产品描述及应用	2
2. 安装说明	3
2.1. 外形尺寸	3
2.2. 与执行器组装	5
2.2.1. 与直行程执行器组装	5
2.2.2. 与角行程执行器组装	7
2.3. 操作界面角度调整	9
3. 接口说明	11
4. 技术参数	12
4.1. 工作参数	12
4.2. 电气参数	12
4.3. 机械参数	13
4.4. 气动参数	13
5. 操作	14
5.1. 界面描述	14
5.2. 工作模式	15
5.2.1. 初始模式	15
5.2.2. 自动模式	15
5.2.3. 手动模式	15
5.3. 功能说明	16
5.3.1. 自整定	16
5.3.2. 死区设置	17
5.3.3. 紧闭功能开关设置	17
5.3.4. 恢复出厂设置	18

5.3.5.	输入信号错误检测	18
5.3.6.	模拟信号输出（可选）	18
6.	问题排除	18
7.	注意事项	19
8.	保修条款	23
9.	选型及订货数据	24

1. 概述

1.1. 产品结构



图 1. 定位器结构

1.2. 产品描述及应用

1500 系列智能阀门定位器是一款基于微处理器的阀门开度调节器。阀门开度可通过外部输入信号设定。定位器运用自动控制算法和 PWM 控制技术，快速而准确地实现阀门的开度调节。该产品可在密封空间中使用，并实现远程自动控制。它容易安装，操作和维护，并且故障率低。

定位器可以与各种气动阀组合使用。如图 2 所示。

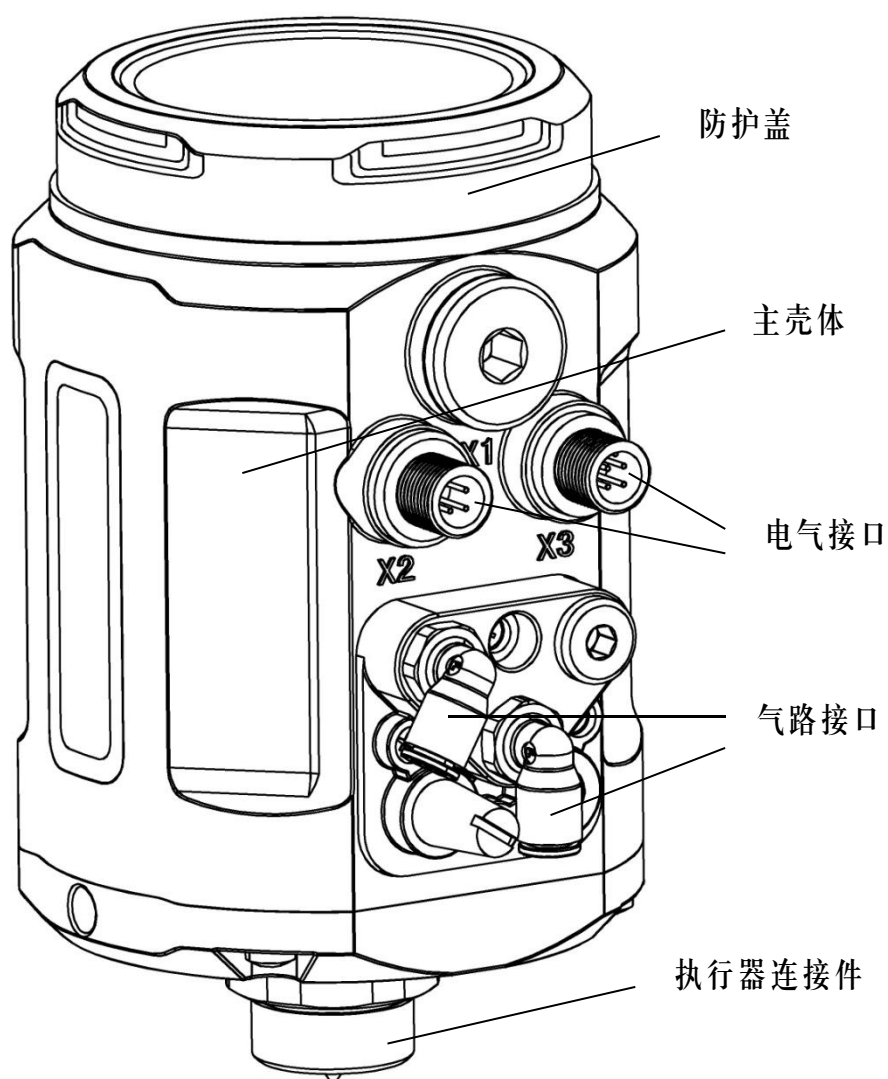

图 2. 定位器与气动阀组合

2. 安装说明

2.1. 外形尺寸



图 3. 直行程外形尺寸



图 4. 角行程外形尺寸

2.2. 与执行器组装

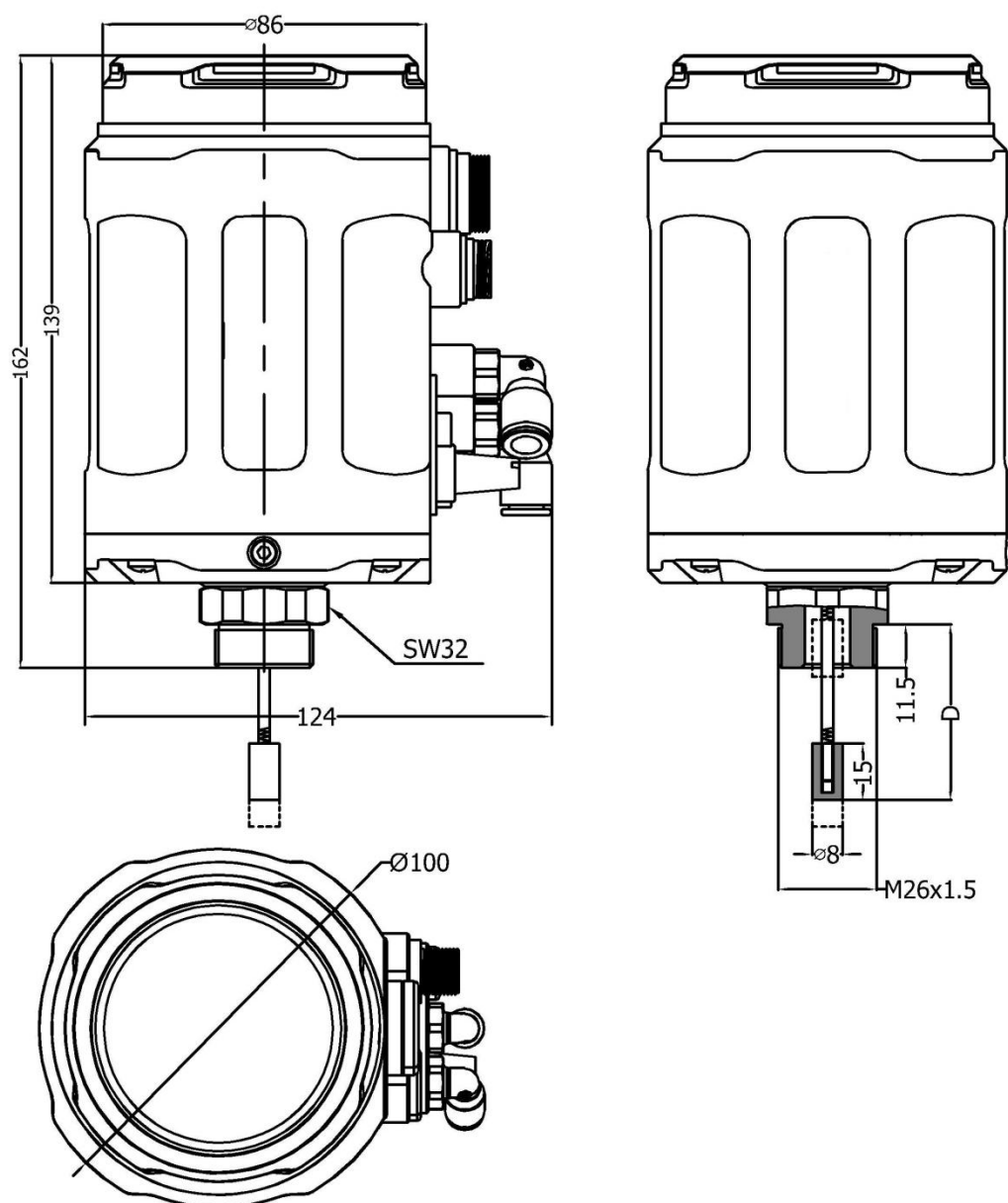
2.2.1. 与直行程执行器组装

1. 确认执行器阀门行程值和执行器顶部螺纹规格是否相符。
2. 阀门处于完全关闭和完全打开状态时,用深度尺分别测量执行器阀杆顶端到执行器顶部安装基准面的距离 C1 值和 C2 值 (图 5 中标注所示),并记录。

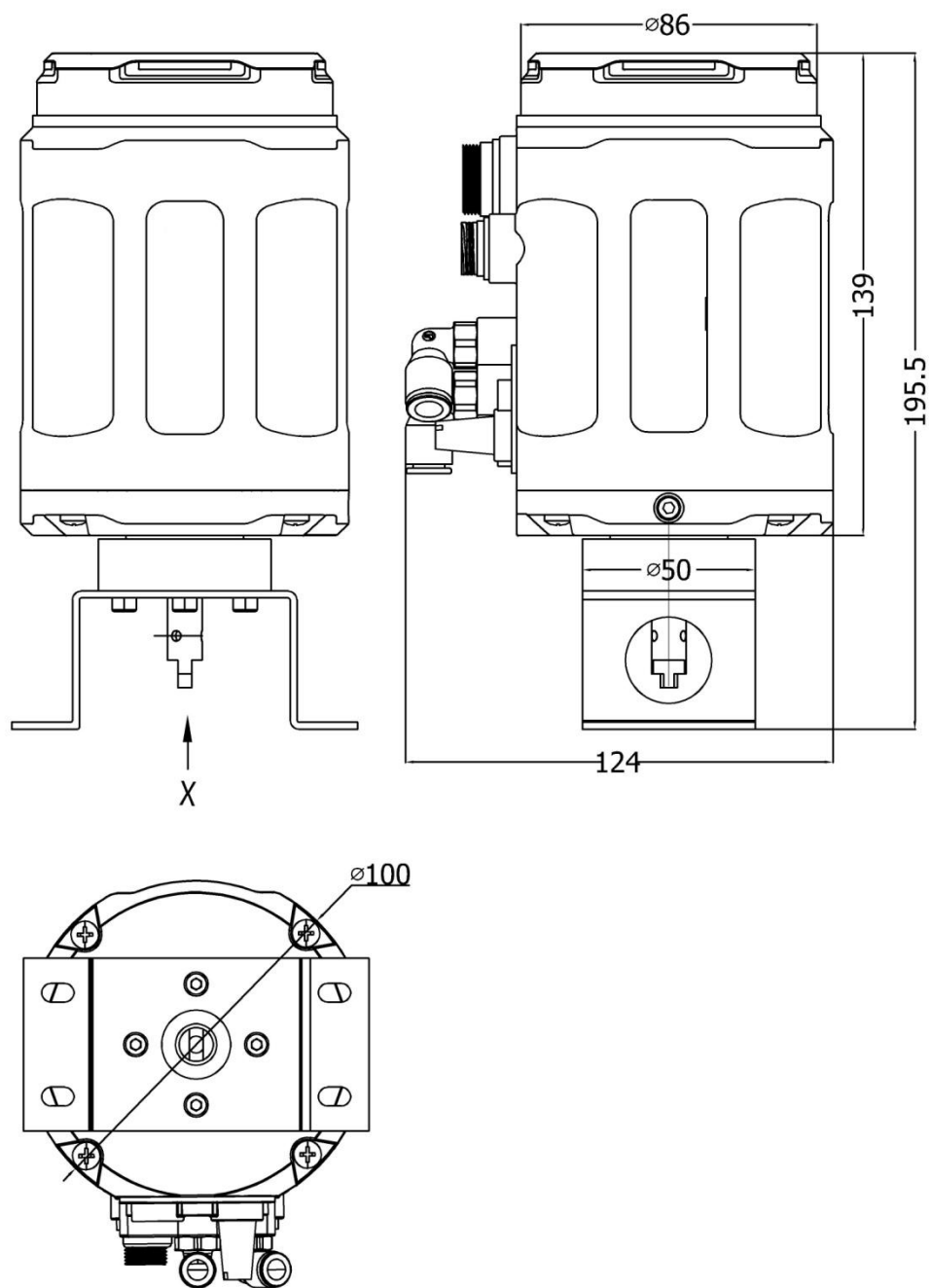

图 5. 执行器测量

3. 调节位移传感器的调节螺母,然后在位移传感器完全松开状态下用深度尺测量 D 值 (图 6 中标注所示)。计算压缩量 $L1 = D - C1$, $L2 = D - C2$ 。建议尽可能使 L1 和 L2 的值在表 1 所示的参考范围内。如果 L1 或 L2 的值无法满足在表 1 所示的参考范围内,则可根据实际情况调节 D 值。

注意!

调节的 D 值必须保证使 $L1 > 0$, $L2 <$ 位移传感器最大压缩量。否则将无法匹配。

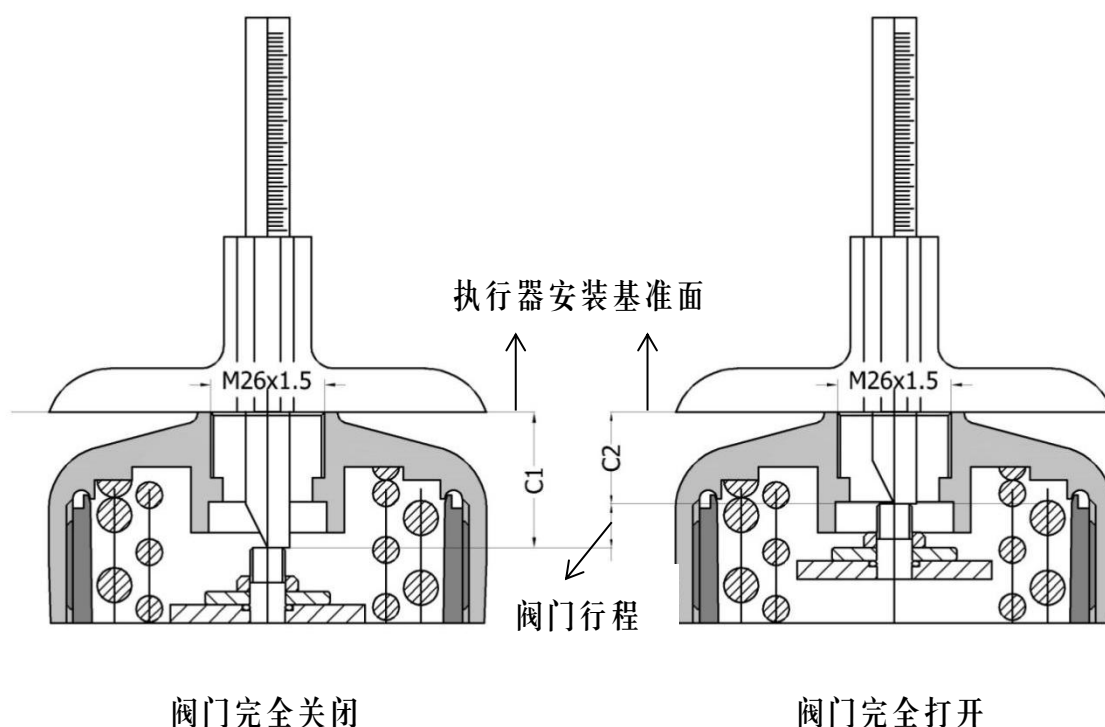
阀门最大行程	D 值范围	压缩量 L1, L2 参考范围
5~25 mm	45~51 mm	3~28 mm
25~50 mm	65~71 mm	3.5~53.5 mm

表 1. 压缩量参考范围



图 6. 位移传感器调节和测量

- 将执行器内部阀杆升到最高位置，用 32 号扳手将定位器底部的执行器连接组件右旋入到执行器对应螺纹接口，并确保旋紧连接组件。如图 7 所示。

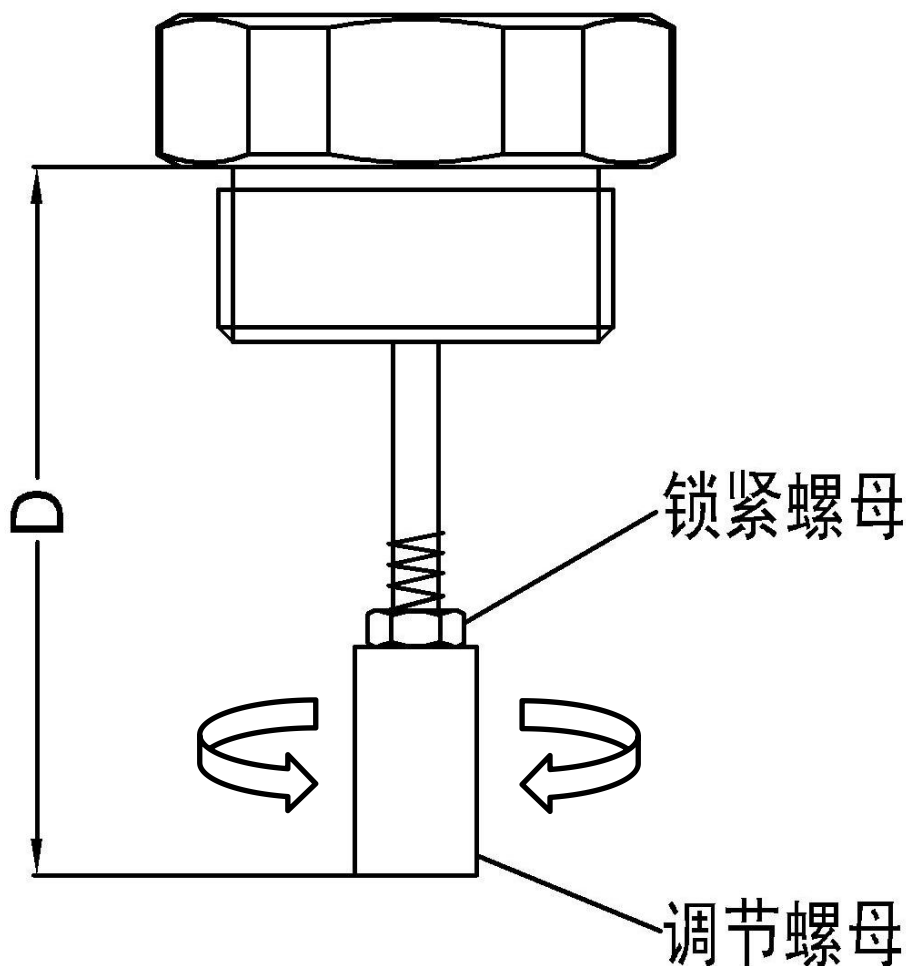

图 7. 定位器与执行器组装

5. 给定位器上电，并在初始模式下手动调节阀位和执行自整定操作，以此来检测阀门行程是否超出位移传感器有效行程范围（详见第五章 5.2.1 节，5.3.1 节）。如果阀门行程超出位移传感器有效行程范围，重新执行第 3 步操作。

2.2.2. 与角行程执行器组装

1. 将安装支架固定在定位器下方。如图 8 所示。
2. 将定位器底部反馈杆插入执行器轴的凹槽内。并将安装支架固定在执行器上。如图 8 所示。

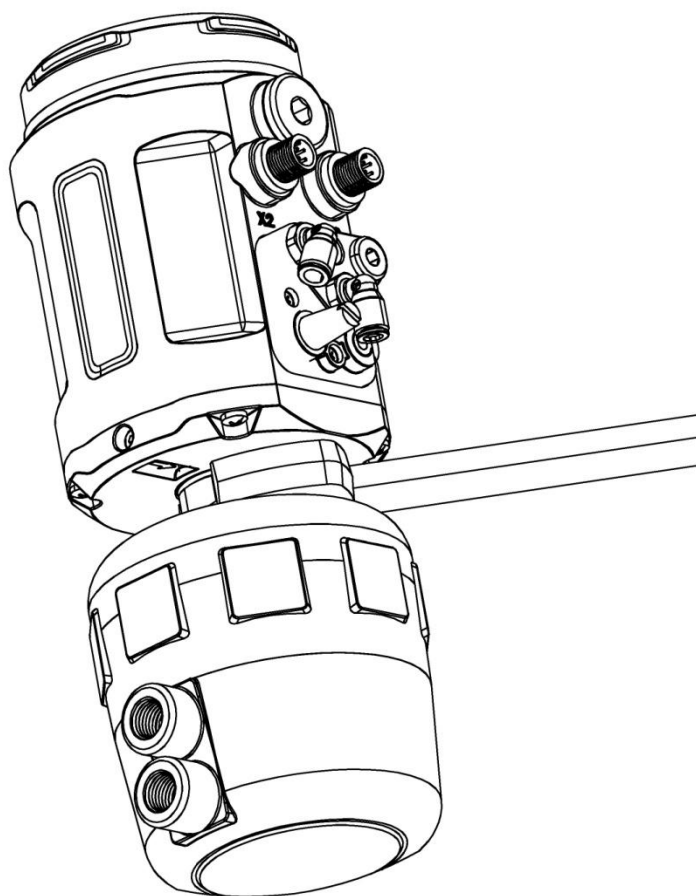

图 8. 安装示意图



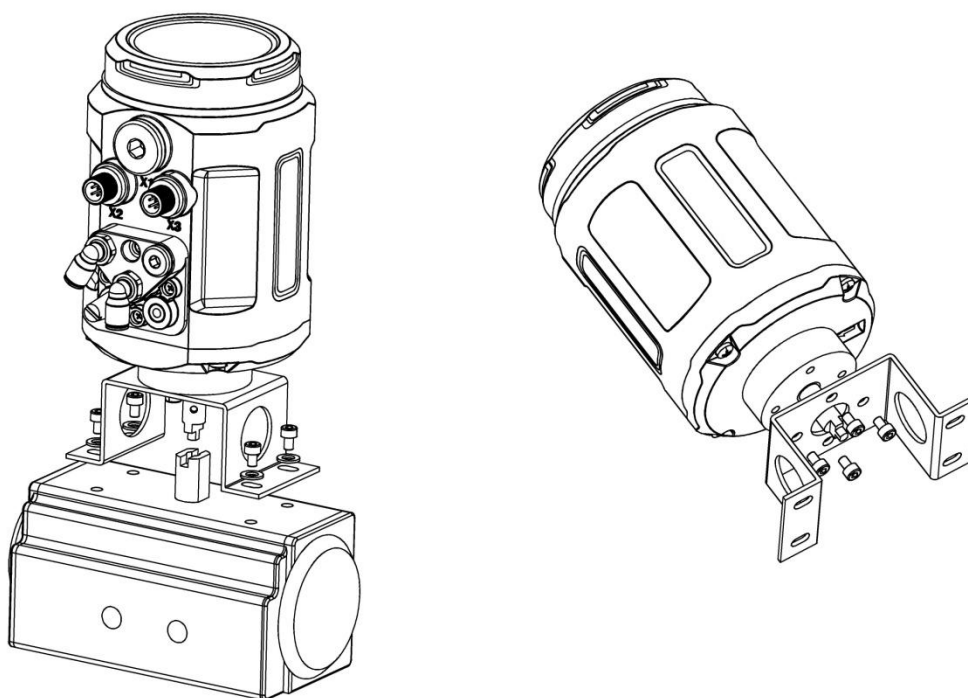
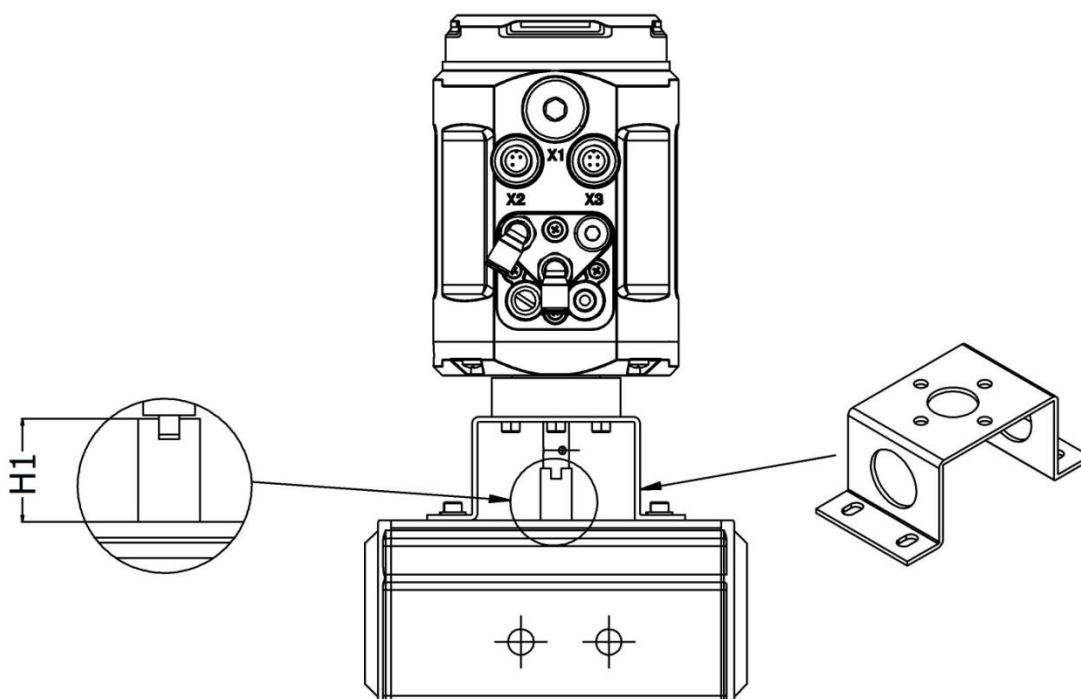
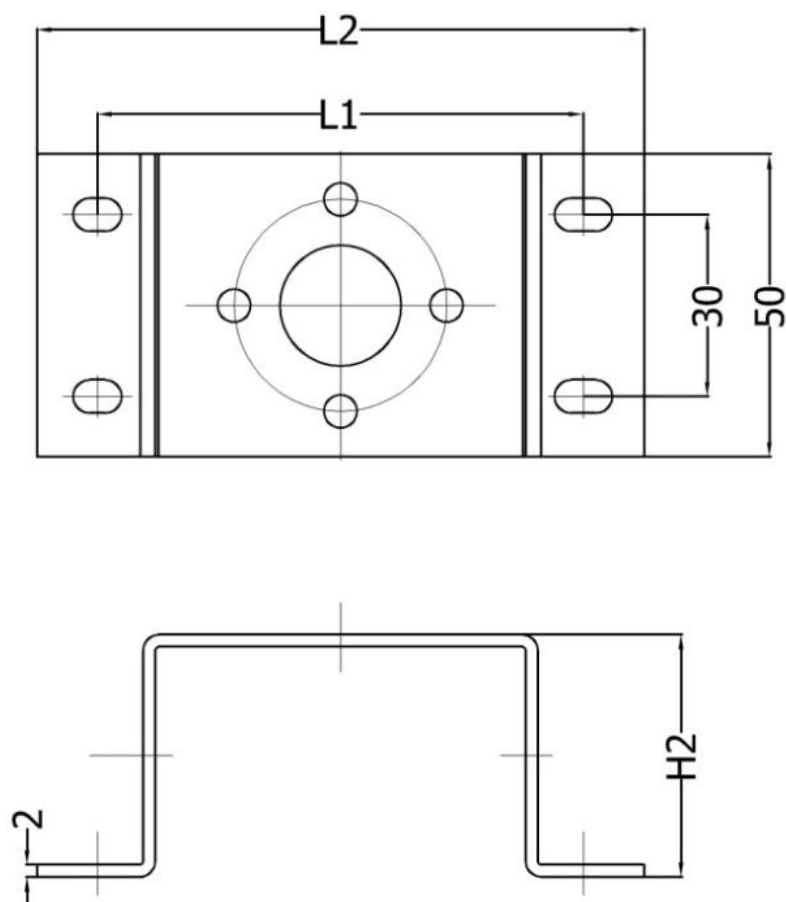

型号	H1	H2	L1	L2
PF-1 (默认)	20	40	80	100
PF-2	30	50	80/130	100/150

图 9. 安装支架尺寸

2.3. 操作界面角度调整

若需要调整定位器操作界面角度，松开 A 处的内六角紧定螺钉后（如图 7 所示），顺时针或逆时针 180° 范围内调整到需要的角度，再拧紧紧定螺钉。



图 10. 调整操作示意图

注意!

定位器内部有旋转限位机构，往一个方向旋转限位后不可强行旋转。

3. 接口说明

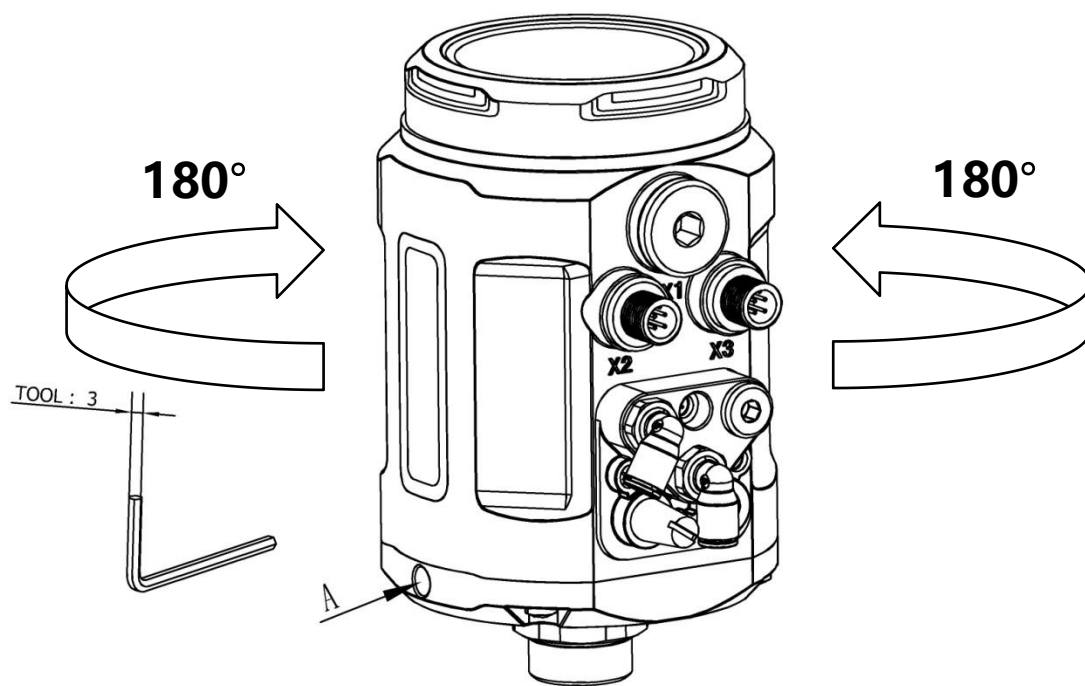

图 11. 接线端子

端口标注	端子号	描述	信号类型
X2	1	模拟信号输出 +	4 – 20 mA
	3	模拟信号输出 GND	GND
	4	空	无

表 2. X2 电气端子 (可选)

端口标注	端子号	描述	信号类型
X3	1	电源 +	+24 V
	2	电源 GND	GND
	3	设定信号输入 +	4 – 20 mA
	4	设定信号输入 GND	GND

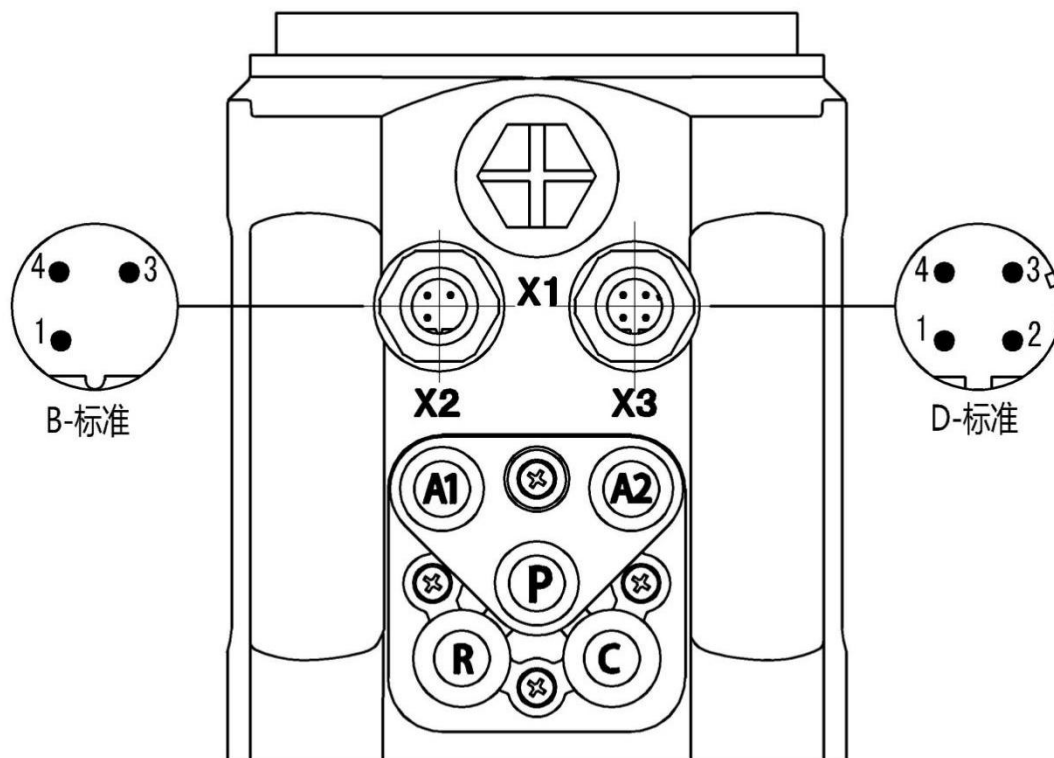
表 3. X3 电气端子

注意!

电气线缆端子接错将可能导致定位器损坏。

端口标注	描述
P	气源进入（内置滤网，过滤尺寸 20 μm）
R	排气
C	单向阀
A1	先导气口 1
A2	先导气口 2

表 4. 气动端子

注意!

气源压力超过 7 bar 可能导致定位器损坏。

4. 技术参数

4.1. 工作参数

环境温度：0~60°C

防护等级：IP67

抗振参数：100Hz

4.2. 电气参数

连接器件：电缆密封接头

供电电源：24 V DC \pm 10 %， \geq 1A。推荐使用开关电源。

功耗：<5W

设定信号输入阻抗：140 Ω

4.3. 机械参数

上盖材料：聚碳酸酯（PC）

密封材料：硅橡胶(SI)

主体材料：聚酰胺(PA6-GF30)

控制行程范围：5~50 mm

4.4. 气动参数

气源压力范围：3~7 bar，具体值视执行机构而定

气动接口规格：1/4 英寸插入式软管接头

气源质量要求：符合 ISO 8573-1

固体颗粒大小和密度 3 级

露点 3 级

含油量 3 级

输出气体流量：17L/min（输入压力为 0.6Mpa）

95L/min（输入压力为 0.6Mpa，仅单作用）

5. 操作

5.1. 界面描述





定位器包括了 4 个按键和 12 个 LED 指示灯。用户可通过 4 个按键来操作定位器相关功能。10 个蓝色指示灯用作数值指示，来显示位移传感器有效行程百分比区间或阀门行程百分比区间。10 个指示灯从左到右分别表示百分比区间 0-10%，10-20%，20-30%，30-40%，40-50%，50-60%，60-70%，70-80%，80-90%，90-100%。“MANUAL”指示灯用于指示工作模式。常亮表示手动模式；不亮表示自动模式；闪烁表示初始模式。“STATUS”指示灯用于指示系统一些运行状态，比如系统错误报警等。



图 12. 操作界面

5.2. 工作模式

5.2.1. 初始模式



定位器出厂时开机默认为初始模式。在初始模式下，“MANUAL”指示灯闪烁显示。10 个蓝色 LED 指示灯用于指示位移传感器有效行程的百分比区间。用户通过操作   键来开启和关闭阀门。持续按  键，执行器进气；持续按  键，执行器排气。根据蓝色数值指示灯和“STATUS”指示灯检测并确保阀门位置可在位移传感器行程范围内自由移动以及阀门行程未超出位移传感器有效行程范围。

当检测到阀门行程超出位移传感器有效行程范围时，阀位保持。此时，如果阀门行程最小值小于位移传感器有效行程范围最小值时，“STATUS”指示灯快速闪烁显示；如果阀门行程最大值大于位移传感器有效行程范围最大值时，“STATUS”指示灯缓慢闪烁显示。系统报错后，用户无法操作按键。

5.2.2. 自动模式

当定位器在初始模式下完成自整定操作，按  键退出自整定，系统处于自动模式。并且重新开机后，系统默认在自动模式。在自动模式下，定位器接收作为设定值的输入信号，并自动调节阀门开度。此时，“MANUAL”指示灯熄灭，10 个蓝色数值指示灯用于指示阀门行程百分比区间。在紧闭功能开启状态下，当设定值 $\leq 1\%$ 时，阀门完全关闭；当设定值 $\geq 99\%$ 时，阀门完全打开。

5.2.3. 手动模式

短按  键来使系统在自动模式和手动模式之间切换。在手动模式下，“MANUAL”指示灯点亮。10 个蓝色数值指示灯用于指示阀门行程百分比区间。在手动模式下，用户操作   按键手动调节阀门开度。用户也可通过操作

组合按键来加快调节速度。当先持续按  键后再持续按  键，阀门快速打开；当先持续按  键后再持续按  键，阀门快速关闭。

5.3. 功能说明

5.3.1. 自整定



自整定功能能够自动测量定位器的相关控制参数。包括行程方向，阀门行程范围，控制电磁阀的 PWM 参数等。

在任何工作模式界面下，长按  键 3 秒左右，开始运行自整定功能。自整定功能运行过程中，蓝色数值指示灯会滚动显示自整定步骤。当自整定完成后，10 个蓝色数值指示灯全部闪烁显示。如果自整定错误，“STATUS”指示灯常亮显示，阀位保持。

自整定运行过程中会同时检测阀门行程是否超出位移传感器有效行程范围。当检测到阀门行程超出位移传感器有效行程范围时，阀位保持。此时，如果阀门行程最小值小于位移传感器有效行程范围最小值时，“STATUS”指示灯快速闪烁显示；如果阀门行程最大值大于位移传感器有效行程范围最大值时，“STATUS”指示灯缓慢闪烁显示。

自整定运行过程中会检测执行器是否有漏气。当检测到执行器漏气时，阀位保持，“STATUS”指示灯间隔 2 秒闪烁 2 次。





自整定运行过程中，可按  键退出自整定，并转到原先的工作模式。

自整定完成后，如果原先工作模式为自动模式或手动模式，按  键退出到原先的工作模式；如果原先工作模式为初始模式，按  键退出到自动模式。

注意!

- 虽然在出厂前已进行过自整定,但是为了能获取工作环境下的控制参数。用户还是必须在实际工作环境下对定位器执行自整定操作。
- 在自整定过程中,确保气源压力在执行器工作的压力范围内并且没有大的波动,否则可能导致自整定参数出错或自整定失败。



5.3.2. 死区设置

此功能用于调节阀位控制精度。当阀位值和设定值之间的差值 \leq 死区值时,系统认为调节到位而不做位置调节动作。死区最小值为 0.2%,最大值为 5%。9 个蓝色指示灯从左至右依次用来表示 0.2%, 0.4%, 0.6%, 0.8%, 1%, 2%, 3%, 4%, 5%这 9 个死区值。在自动模式下,长按  键 3 秒左右进入死区设置界面。其中一个蓝色数值指示灯闪烁显示当前的死区值。按   键改变死区值,修改值通过蓝色数值指示灯闪烁显示。按  键确认更改并返回到自动模式界面。按  键返回到自动模式界面而不改变当前死区值。

注意!



死区设置的越小,所获得的精度越高。请根据匹配的执行器动态特性合理设置此值。因为过小的值可能使电磁阀频繁动作,导致长的调节时间和运行不稳定。

5.3.3. 紧闭功能开关设置

此功能用于设置紧闭功能的开启和关闭。在初始模式或自动模式下,长按  键 3 秒左右进入设置界面。最左边蓝色指示灯闪烁表示紧闭功能开启,最右边蓝色指示灯闪烁表示紧闭功能关闭。按  键切换开启和关闭。按  键确

认更改并退出。按  键退出而不改变设置。

5.3.4. 恢复出厂设置

此功能使定位器恢复到出厂设置状态。在自动模式下，长按  +  键 3 秒左右运行此功能。当此功能完成后，定位器处于初始模式，死区值为 1%，紧闭功能开启。如果定位器与执行器匹配安装前，定位器上电默认不在初始模式，则必须使定位器恢复到出厂设置状态，再进行匹配安装。

5.3.5. 输入信号错误检测

此功能用于系统运行在自动模式下检测输入的 4-20mA 设定信号的错误。信号出错条件为信号值 $\leq 3.5\text{mA}$ 。当检测到错误信号时，“STATUS”指示灯闪烁显示。单作用断电复位定位器将排空执行器气缸空气。单作用断电保持定位器将使阀位保持（默认）或关闭（根据客户需求）。双作用定位器将使阀位处于自由态。

5.3.6. 模拟信号输出（可选）

定位器运行在自动模式或手动模式时，输出反映阀位值的 4-20mA 模拟信号。初始模式或自整定状态下不输出信号。

6. 问题排除

1. 定位器上电后 LED 指示灯不亮

确保直流 24V 电源供电正常，供电线缆连接正确。

2. 定位器长时间无法定位或者阀门无法全开或全关

确保进气气压达到要求；确保设置的死区值能够满足阀位稳定调节，无波动；确保执行机构和定位器的气动端口没有漏气现象。

7. 注意事项

1. 您采购的定位器的电源电压为 24V DC $\pm 10\%$ ，请用万用表确认后再接入定位器电气端子。连接电气端子到定位器前请确认电源是否切断。接入过大电压造成的产品损坏不在保修范围内。
2. 气源使用规范
 - 1> 产品的气源供气压力最大不能超过 0.7MPa。
 - 2> 产品的气源连接口前方必须安装过滤精度为 5um 的过滤减压器，防止水分，油污等异物渗入。对于压缩空气中油污比较多的情况，建议增加安装过滤精度 0.3um 以下的油雾分离器。推荐用户使用 SMC 过滤器和油雾分离器，型号为 AC20D-01CG-A。对于未加装以上要求的过滤减压器或油雾分离器导致过量油污进入定位器内部造成元器件损坏的不在保修范围内。
3. 定位器调试完毕后，1500 定位器顶部防水防尘盖务必旋紧，以保证整个产品 IP66 防水等级。如未旋紧或者丢失防水防尘盖造成的定位器损坏不在保修范围内。

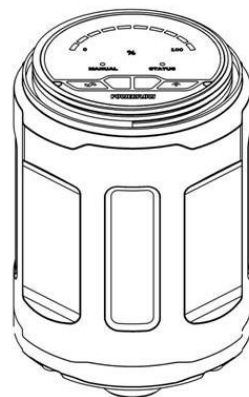
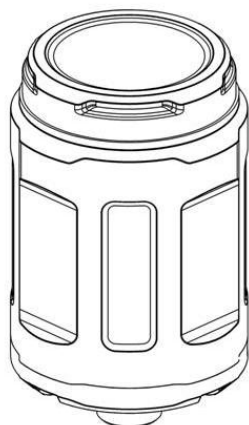

4. 防水电气接头使用规范

1> 电气接口有防呆设计，请按照 X2、X3 标识对应插入到防水针插公头。

如没有对应且强行插入会造成插针弯曲损坏。

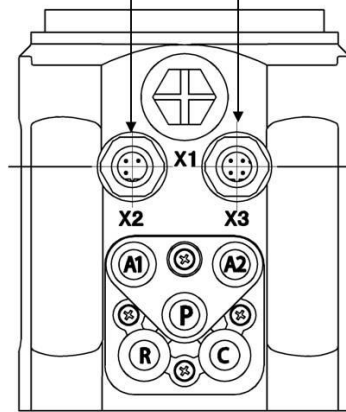
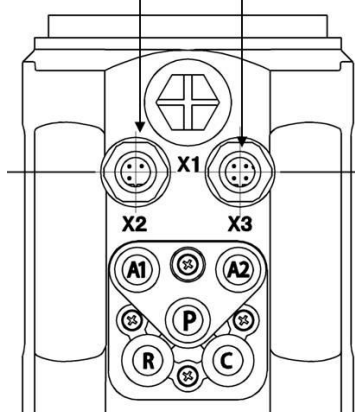
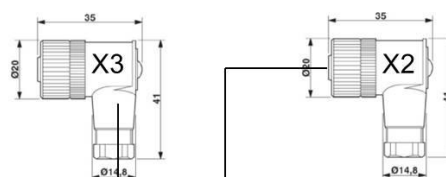
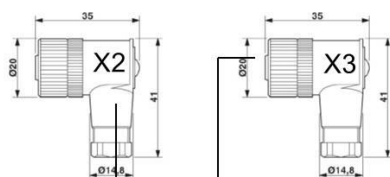

2> 防水电气接头兼容的线缆外径为 PG7(4mm-6mm)。请使用有外部绝缘保护皮的国标多芯线，否则电气接头不能保证 IP66 的防水等级。

正确和错误的接线方式如下图所示：

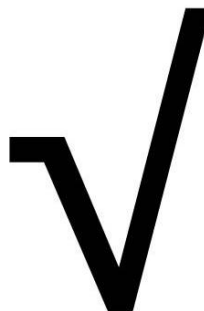

3> 电气接口如长时间不使用，请将防水针插母头连接到定位器防水针插公头，并且用提供的硅胶堵头将引线口堵死。防止水蒸气或者腐蚀性气体腐蚀插针或侵入损坏定位器。

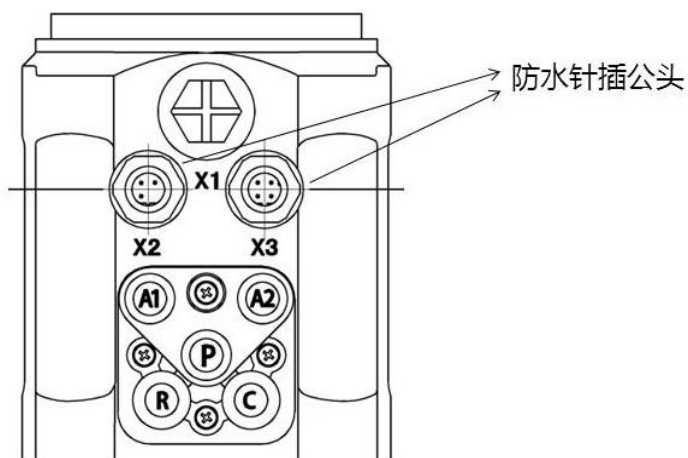

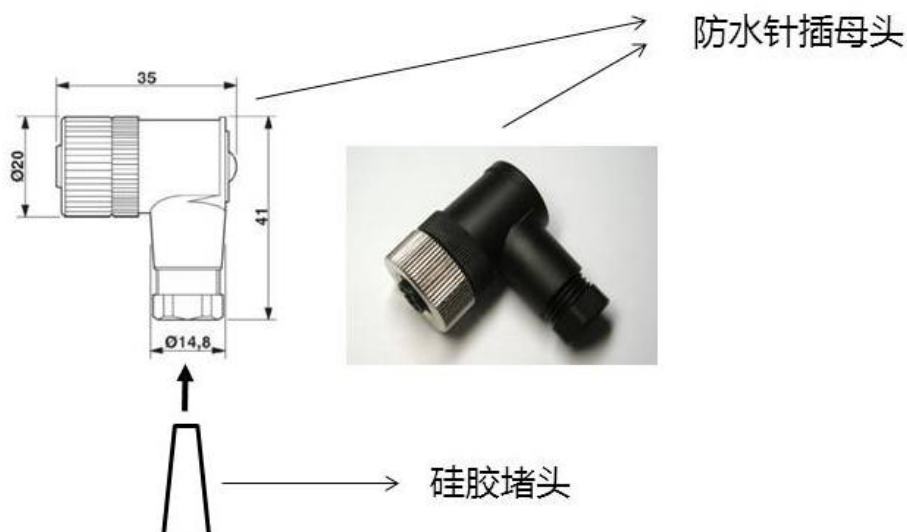

未严格按上述防水电气接头使用规范使用防水接头造成的定位器损坏不在保修范围内。

5. 用户私自拆除定位器上的气动接头或气动接头处的滤网而造成的定位器损坏不在保修范围内。
6. 对于定位器匹配角行程执行机构。务必保证角行程执行机构轴的凹槽处于垂直状态，使执行机构轴和定位器传感器主轴尽量同心。否则产生的径向负荷力会使定位器传感器损坏，对于上述原因造成的定位器损坏不在保修范围内。

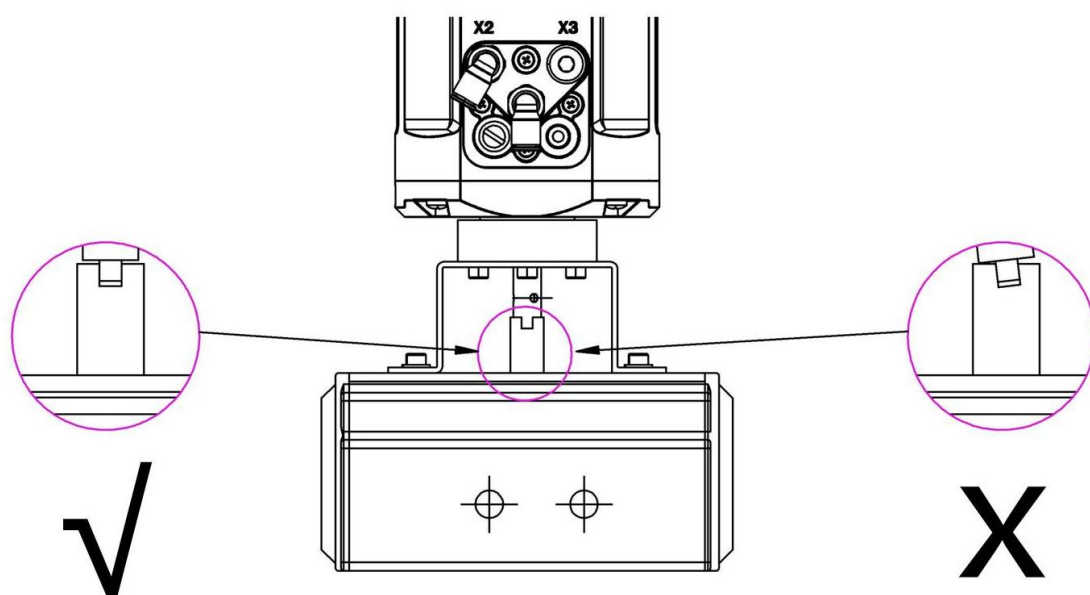

8. 保修条款

1. 发现产品有质量问题，经我公司人员确认后，客户享有在质保期内免费更换或维修的售后服务。服务响应时间为 24 小时（非工作日除外）。
2. 产品的质保期以本公司最新质保政策为准，不低于售出后 12 个月。
3. 如下情况的返修品，不属质保范围：
 - (1) 超过质保期的产品。
 - (2) 未经我公司授权和允许，私自拆装过的产品。
 - (3) 未按产品使用说明书操作或其他人为因素造成的产品损坏，包括但不限于：
 - 1> 产品表面有碰撞伤痕。
 - 2> 接线或供电错误造成元器件损坏。
 - 3> 零部件或配件丢失。
 - 4> 未加装过滤减压器或油雾分离器导致油污进入产品内部造成元器件损坏。
 - 5> 未旋紧或丢失防护盖导致产品损坏。
 - 6> 未按使用规范使用防水电气接头导致产品损坏。
 - (4) 不可抗拒因素（自然灾害）造成产品故障或损毁。
4. 不属于产品质保范围的维修，我公司将视实际情况提供免费或收费维修服务。
5. 本条款自双方签定供货合同时生效。

9. 选型及订货数据

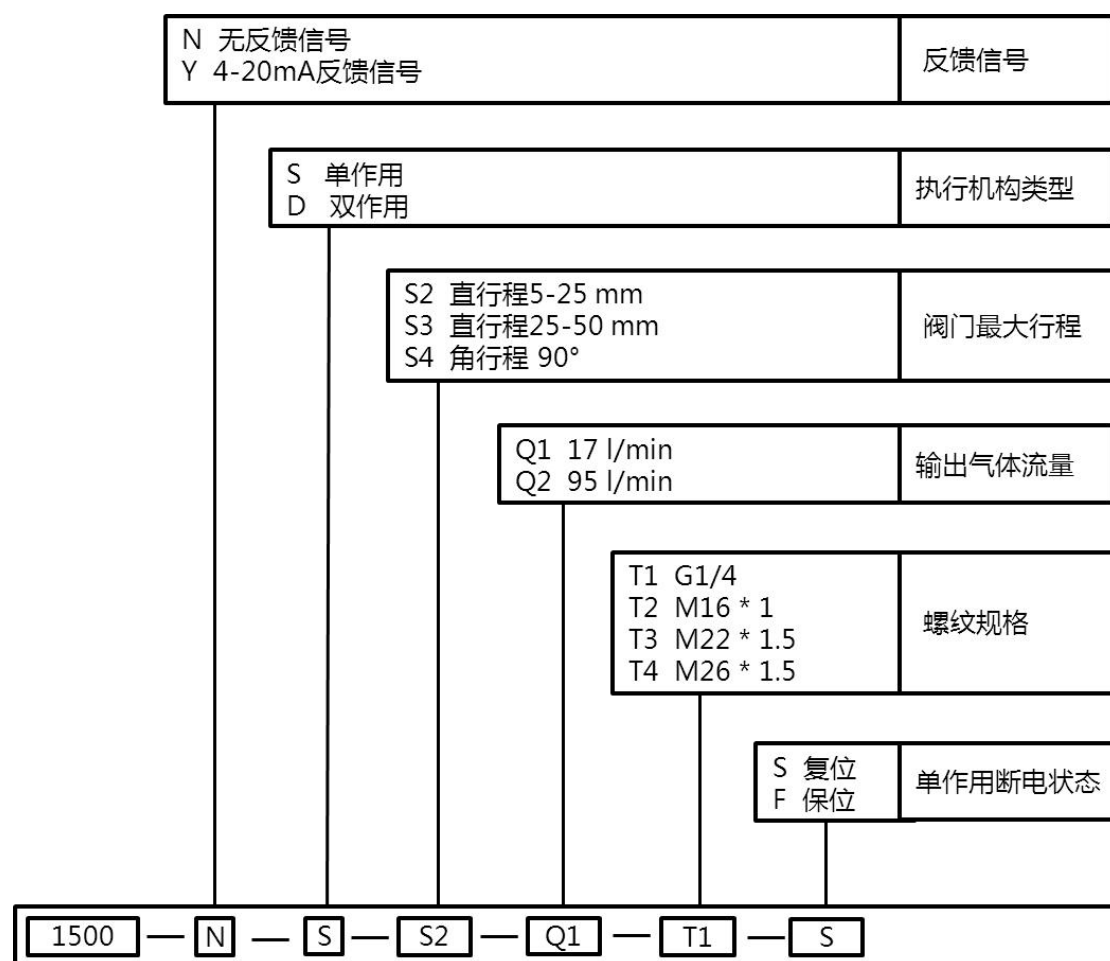

备注：

输出气体流量选项中，代码 Q1 建议匹配气室内径 40-100 mm 的执行器，代码 Q2 建议匹配气室内径 125-160 mm 的执行器。代码 Q2 仅适用于单作用执行器，且断电时只支持保位状态。代码 Q1、Q2 标注的气体流量均为输入压力在 0.6Mpa 下的气体流量。

阀门最大行程选项中代码 S4 适用的 AT 执行器范围是 AT50~AT125。其他型号请客户咨询我司。如果选择代码 S4，则螺纹规格选项不需要选择。

单作用断电状态默认为复位。

Contents

1. Overview	27
1.1. Product structure	27
1.2. Product description and application	28
2. Installation	29
2.1. Mechanical dimensions	29
2.2. Actuator combination	31
2.2.1. Actuator of line stroke	31
2.2.2. Actuator of angle stroke	33
2.3. Interface angle adjustment	35
3. Connection description	37
4. Technical data	38
4.1. Working data	38
4.2. Electrical data	38
4.3. Mechanical data	39
4.4. Pneumatic data	39
5. Operation	39
5.1. Interface description	39
5.2. Operating mode	40
5.2.1. Initial mode	40
5.2.2. Automatic mode	41
5.2.3. Manual mode	41
5.3. Function instruction	41
5.3.1. Auto-tuning	41
5.3.2. Dead band setting	42
5.3.3. Cut off function switch setting	43
5.3.4. Factory setting	43
5.3.5. Input signal error detection	44

5.3.6. Analogue signal output (optional).....	44
6. Trouble shooting.....	44
7. Attention.....	45
8. Warranty terms.....	49
9. Selection and ordering data.....	50

1. Overview

1.1. Product structure

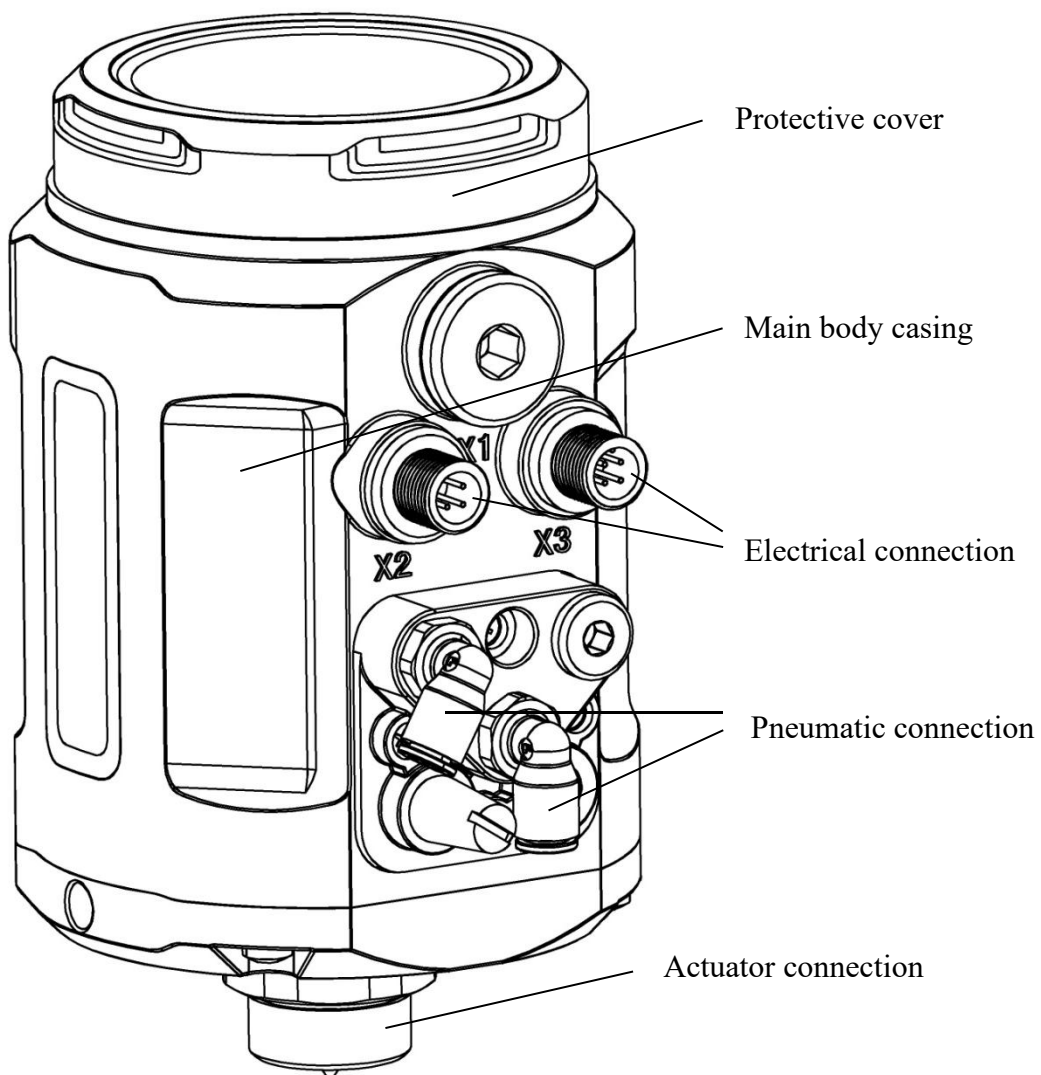

Figure 1. Positioner structure

1.2. Product description and application

1500 series intelligent valve positioner is a valve stroke controller based on microprocessor. The valve stroke can be set by external input signal. The positioner can adjust valve stroke quickly and accurately by using automatic control algorithm and PWM control technology. The product can be used in sealed space and controlled automatically and remotely. It is easy to install, operate, maintain and has low failure rate.

The positioner can combine with different pneumatically actuated valves for using. As shown in Figure 2.



with diaphragm valve



with angle seat valve

Figure 2. Combinations of positioner and pneumatically actuated valves

2. Installation

2.1. Mechanical dimensions

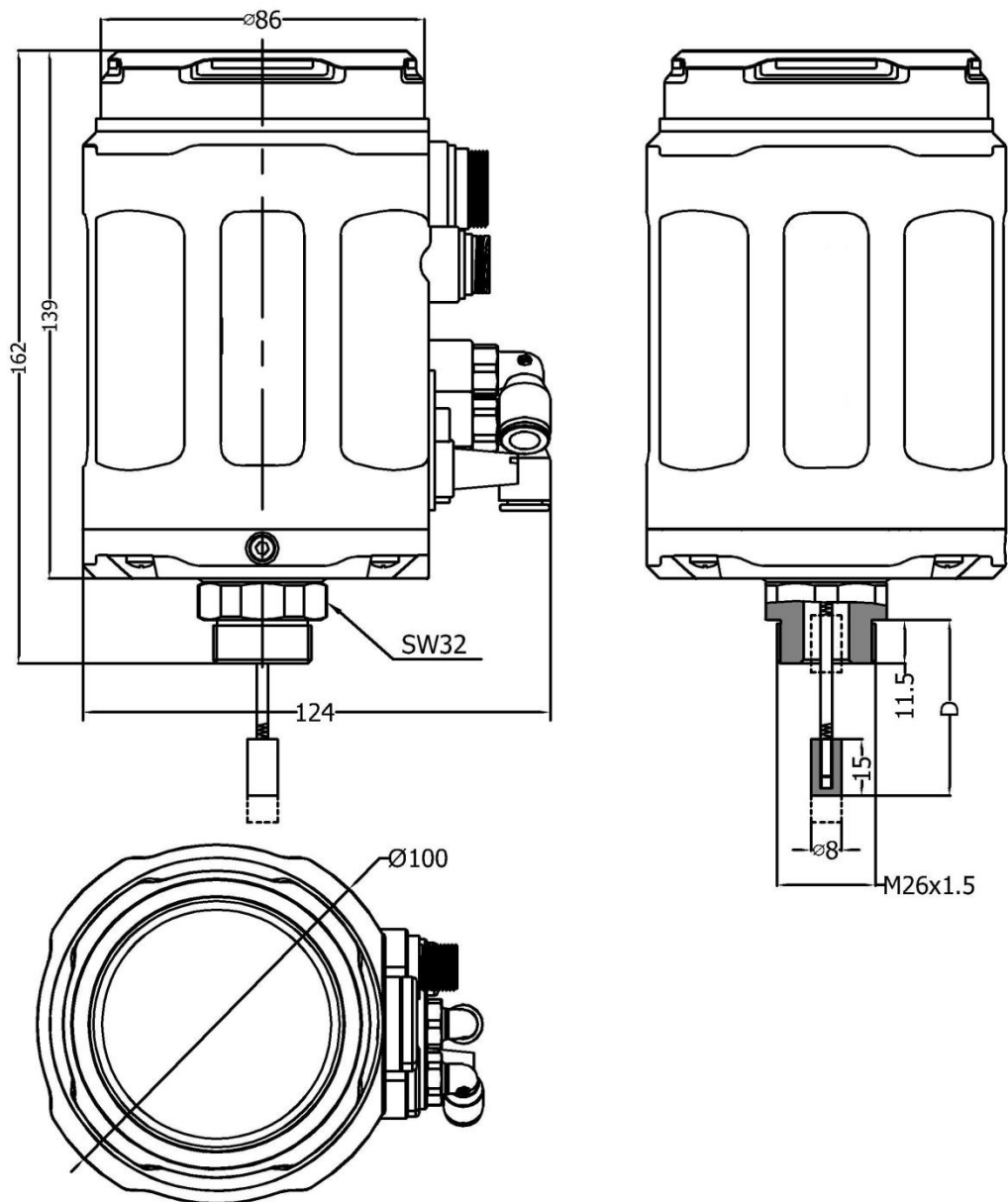

Figure 3. Mechanical dimensions for line stroke

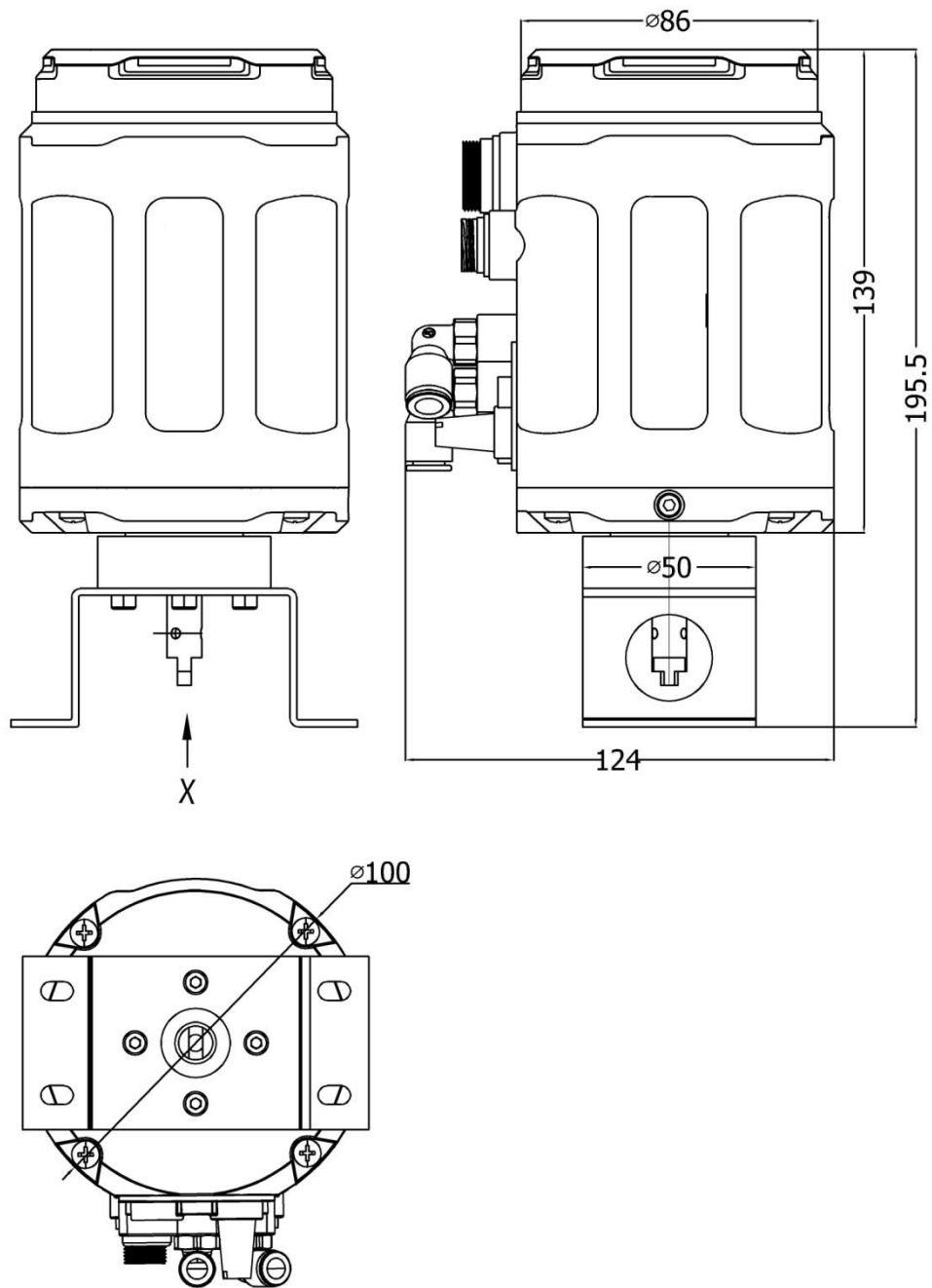

Figure 4. Mechanical dimensions for angle stroke

2.2. Actuator combination

2.2.1. Actuator of line stroke

1. Make sure that the stroke range and the screw thread size of the actuator which needs to combine meet the requirements.
2. Separately measure the C1 value when the valve is fully closed and C2 value when the valve is fully open by **the depth ruler**. The values are the distance between the stem top and the datum clamp face of the actuator. As shown in Figure 5.

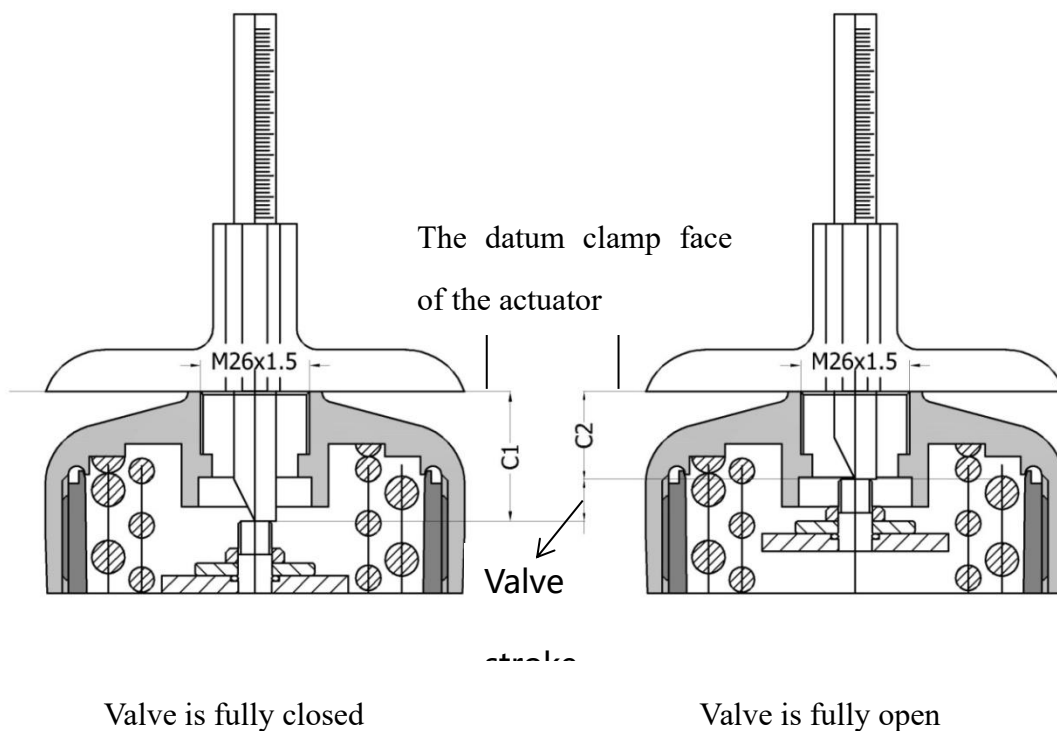

Figure 5. Actuator measurement

3. Adjust the adjusting nut of the displacement sensor. Then measure the D value (as shown in Figure 6) by **the depth ruler** in the state of the displacement sensor being completely loosened. Calculate the compression value $L1 = D - C1$, $L2 = D - C2$. It is recommended that the compression value L1 and L2 are both in the reference range which is showed in Table 1. If L1 value or L2 value is unable to meet the reference range, adjust the D value according to the actual situation.

NOTE!

The adjusted D value must ensure that $L1 > 0$, $L2 <$ the maximum compression value of the displacement sensor. Otherwise, the positioner cannot match the actuator.

Maximum valve stroke	D range	L1, L2 reference range
5~25 mm	45~51 mm	3~28 mm
25~50 mm	65~71 mm	3.5~53.5 mm

Table 1. The reference range of the compression value

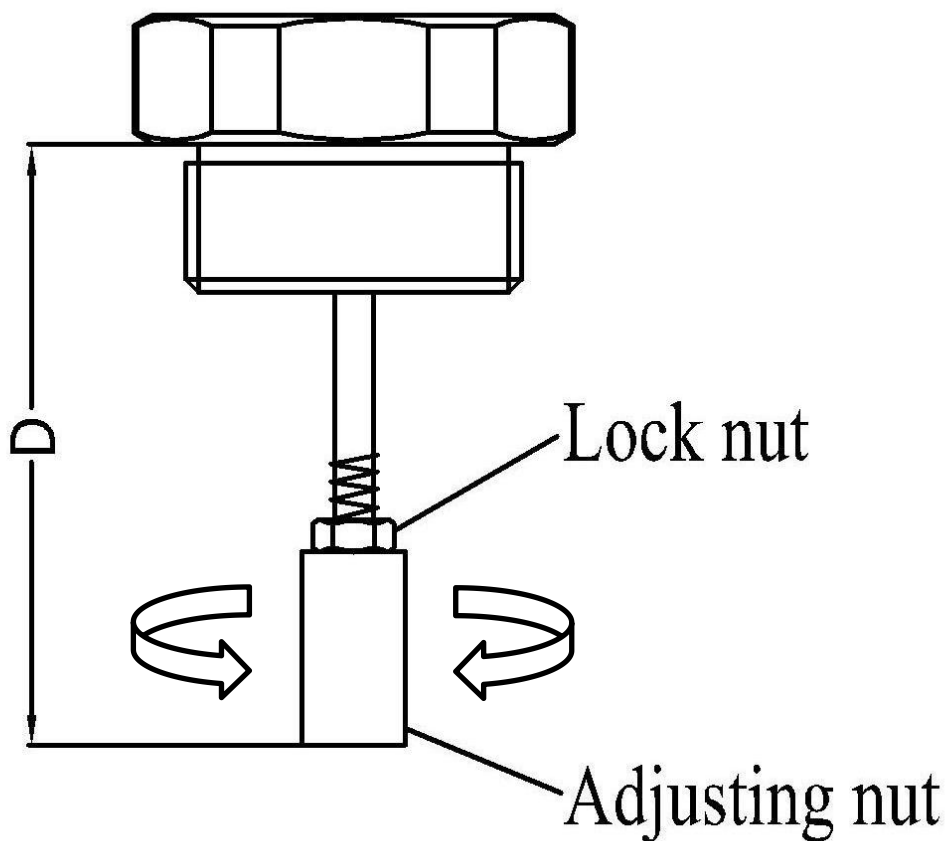

Figure 6. Travel sensor adjustment and measurement

4. Raise the internal valve stem of the actuator to the highest position. Make the actuator connection of the positioner entering into the thread connection of the actuator by **NO.32 wrench**. As shown in Figure 7.

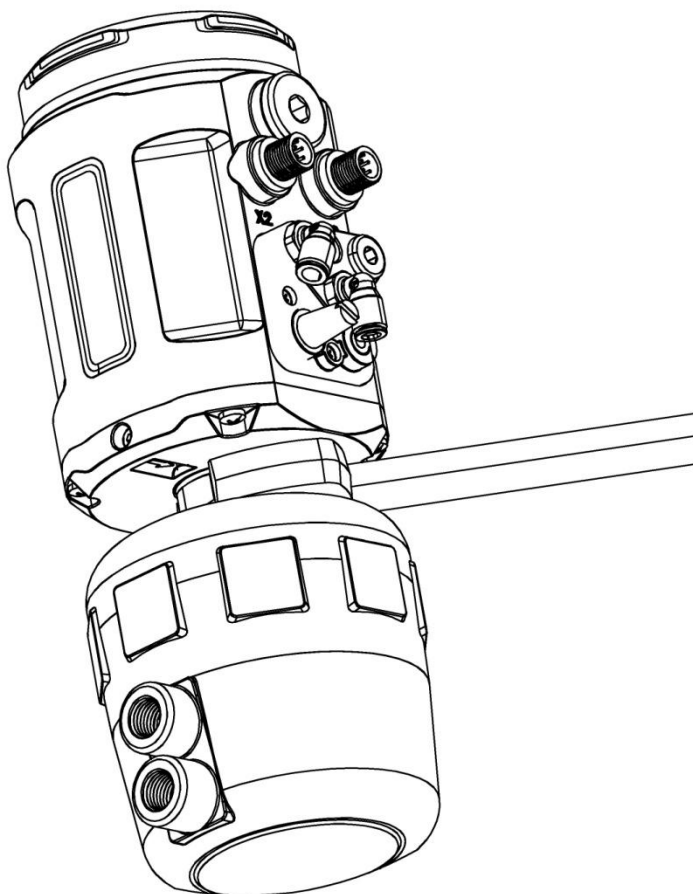

Figure 7. Actuator Combination

5. Power up the positioner, adjust the valve position manually and run the auto-tuning function in the initial mode. Check that whether the whole valve stroke range is in the effective range of the displacement sensor (Refer to the Chapter 5 Section 5.2.1 and Section 5.3.1 for details.). If not, repeat step 3.

2.2.2. Actuator of angle stroke

1. Fix the mounting body under the positioner. As shown in Figure 8.
2. Connect the feedback pole of the positioner with the axis of the actuator. As shown in Figure 8.

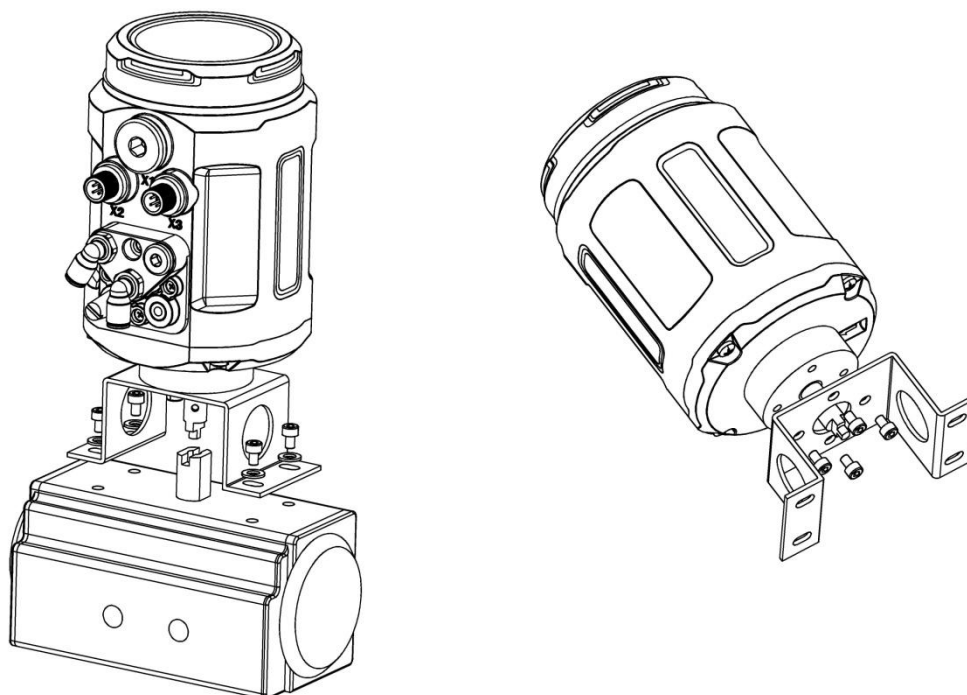
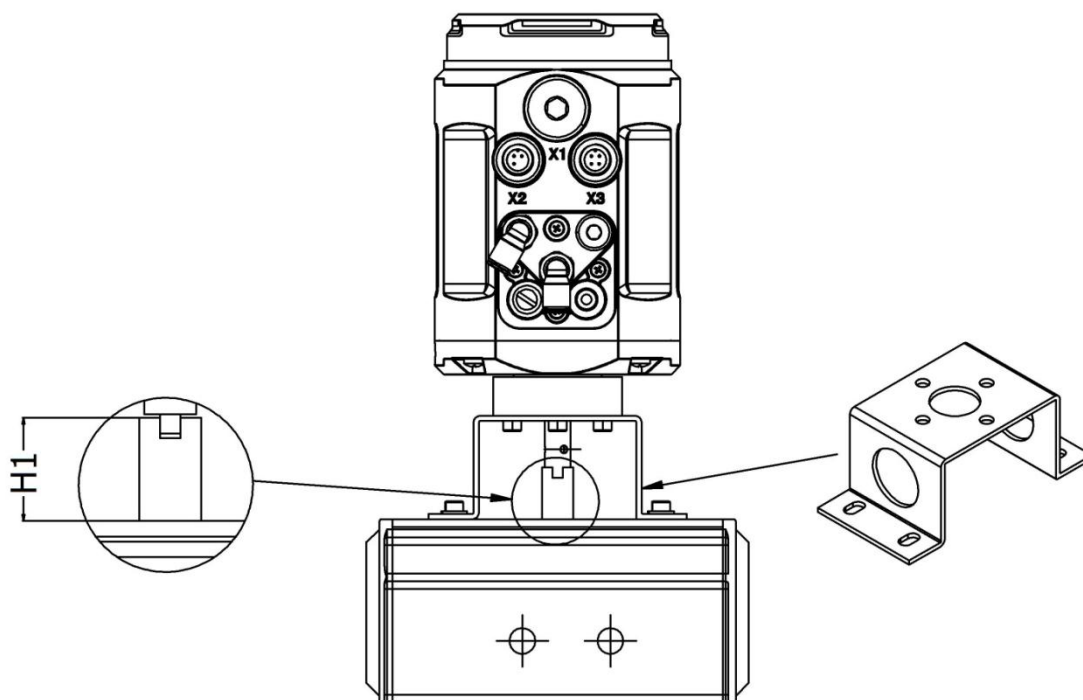
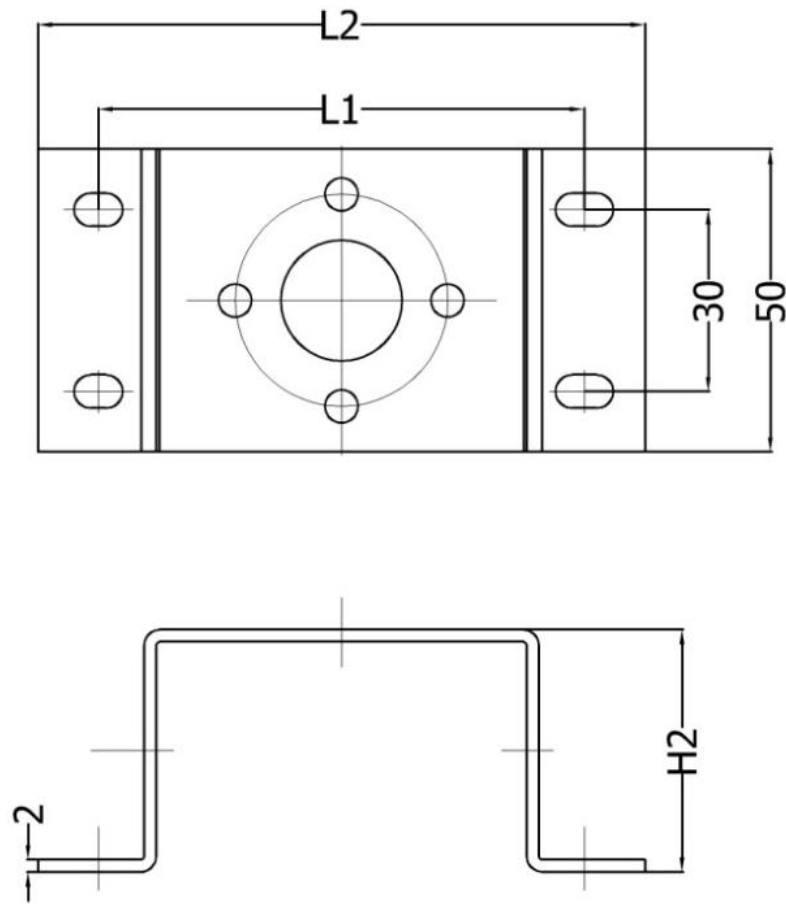

Figure 8. Graph Installation





Type	H1	H2	L1	L2
PF-1 (Default)	20	40	80	100
PF-2	30	50	80/130	100/150

Figure 9. Mechanical dimensions of the mounting body

2.3. Interface angle adjustment

If you need to adjust the interface angle, relax the hexagon screw in place A (As shown in Figure 7) first. Then adjust the angle clockwise or counter-clockwise in 180°range. After adjusting the angle, lock the angle by the hexagon screw.

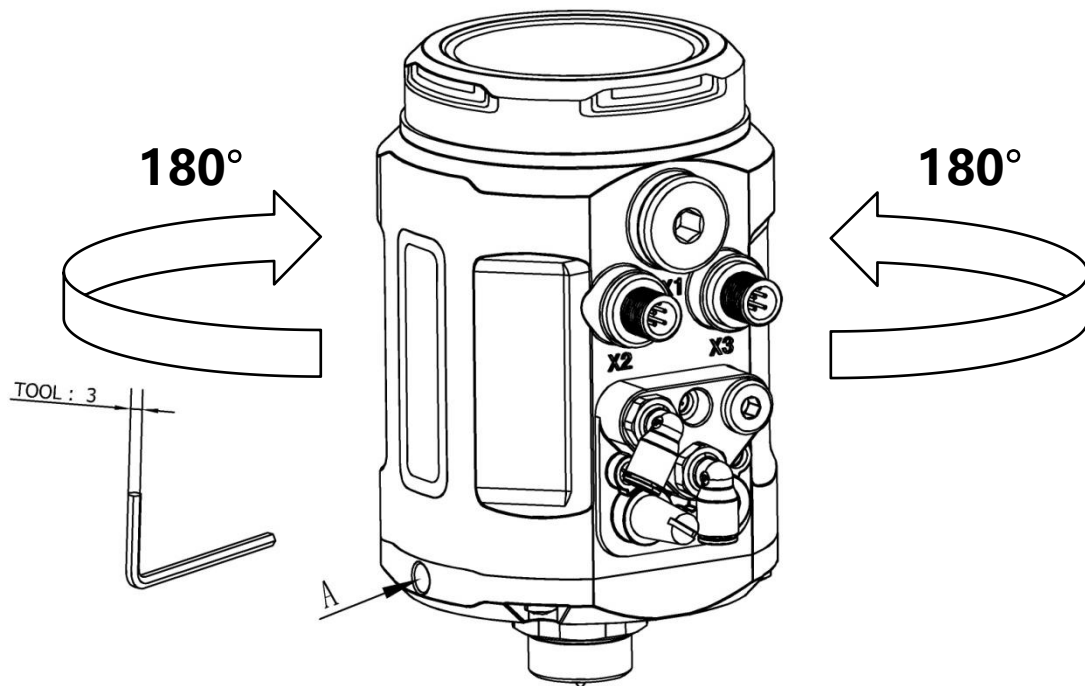

Figure 10. Graph operation

NOTE !

The positioner has rotation stopper mechanism. If it is restricted to rotate in one direction, please do not force to rotate continuously.

3. Connection description

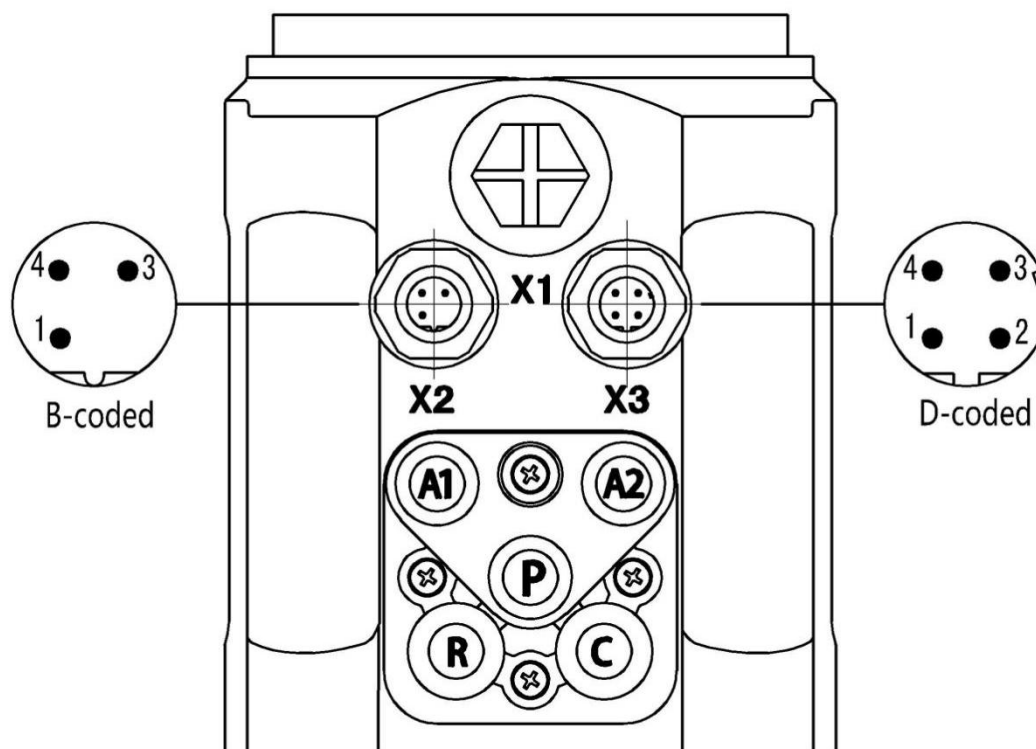

Figure 11. Connection

Connection	Pin	Description	Signal Type
X2	1	Analogue signal output +	4 – 20 mA
	3	Analogue signal output GND	GND
	4	NC	NULL

Table 2. Electrical connection description – X2 (optional)

Connection	Pin	Description	Signal Type
X3	1	Power supply +	+24 V
	2	Power supply GND	GND
	3	Set signal input +	4 – 20 mA
	4	Set signal input GND	GND

Table 3. Electrical connection description – X3

NOTE !

Error connection of the electrical pin may cause the positioner damage.

Connection	Description
P	Air supply enter (built-in filter, filter size 20 μm)
R	Air exhaust
C	Check valve
A1	Pilot air outlet 1
A2	Pilot air outlet 2

Table 4. Pneumatic connection description

NOTE !

The air source pressure bigger than 7 bar may cause positioner damage.

4. Technical data

4.1. Working data

Ambient temperature: 0~60°C

Protection class: IP67

Vibration resistance parameter: 100Hz

4.2. Electrical data

Connections: cable gland

Supply voltage:

24 V DC \pm 10 %, \geq 1A. Recommend switching-mode power supply.

Power input: <5W

Input resistance for set-point signal: 140 Ω

4.3. Mechanical data

Cover material: Polycarbonate (PC)

Sealing material: Silicone rubber (SI)

Main body material: Polyamide Resin (PA6-GF30)

Control stroke range: 5-50 mm

4.4. Pneumatic data

Air pressure range: 3~7 bar, specific values depending on the actuator

Connections: Plug-in hose connector G1/4

Air quality:

ISO 8573-1

Solid particle size and density Class 3

Dew point Class 3

Oil content Class 3

Air flow rate:

17L/min (input pressure of 0.6Mpa)

95L/min (input pressure of 0.6Mpa, only single-acting)

5. Operation

5.1. Interface description





The positioner has a 4-key and 12-led control panel. User can set parameters and functions by pressing the four keys. 10 blue led lights are used to indicate the position percent zone of the displacement sensor or the position percent zone of the valve. They indicate the percent zones of 0-10%, 10-20%, 20-30%, 30-40%, 40-50%, 50-60%, 60-70%, 70-80%, 80-90%, 90-100%. The “MANUAL” led is used to indicate the operating mode. Led off indicates automatic mode. Led on indicates manual mode. Led flash indicates initial mode. “STATUS” led is used to indicate some system running states, such as system error alarms.



Figure 12. Operating interface

5.2. Operating mode

5.2.1. Initial mode







The positioner is default in the initial mode when it starts up after leaving factory. In the initial mode, the “MANUAL” led is flash, 10 blue led lights indicate the position percent zone of the displacement sensor effective stroke. User can operate   keys to open and close the valve. Press  key continuously, the actuator is aerated. Press  key continuously, the actuator is deaerated. Check out and make sure that valve position can move in the effective range of the displacement sensor and the whole valve stroke range is in the effective range of the displacement sensor according to 10 blue led and “STATUS” led.

If the whole valve stroke range is out of the effective range of the displacement sensor, valve position is held. If the minimum value of the whole valve stroke range is smaller than the minimum value of the effective range of the displacement sensor, the “STATUS” led is flash quickly. If the maximum value of the whole valve stroke range is larger than the maximum value of the effective range of the displacement sensor, the “STATUS” led is flash slowly. After system reporting the error, user can't operate keys.

5.2.2. Automatic mode

After the positioner completes the auto-tuning in the initial mode, system is in the automatic mode by pressing  key to exit. And if the positioner restarts up, system is default in the automatic mode. In this mode, the positioner accepts the input signal for set-point value and adjusts the valve stroke automatically, “MANUAL” led is turned off, 10 blue led lights are used to indicate the valve position percent zone. If the cut off function is enabled, the valve is fully close when the percent of set-point value $\leq 1\%$, and is fully open when the percent of set-point value $\geq 99\%$.

5.2.3. Manual mode

Short press  key to switch between the automatic mode and the manual mode. In the manual mode, “MANUAL” led is turned on, 10 blue led lights are used to indicate the valve position percent zone. User can operate   keys to open and close the valve manually. User also can operate combination keys to increase the adjustment speed. If after pressing  key continuously first, press  key continuously, the valve is quickly open. If after pressing  key continuously first, press  key continuously, the valve is quickly close.

5.3. Function instruction

5.3.1. Auto-tuning

The auto-tuning function can test the related control parameters including the direction between the aeration state of the actuator and the actual position, the total valve scale, PWM parameters etc.

Under the any operating mode interface, press  key for about 3 seconds to run the function. During the process of the function running, blue led lights are scrolling to display the step of the auto-tuning.

After finishing the auto-tuning, all 10 blue led lights are flash. If error appears during the auto-tuning, “STATUS” led is turned on, and valve position is held.

System will check whether the whole valve stroke range is in the effective range of

the displacement sensor during the auto-tuning process. If the whole valve stroke range is out of the effective range of the displacement sensor, valve position is held. If the minimum value of the whole valve stroke range is smaller than the minimum value of the effective range of the displacement sensor, the "STATUS" led is flash quickly. If the maximum value of the whole valve stroke range is larger than the maximum value of the effective range of the displacement sensor, the "STATUS" led is flash slowly.

During the auto-tuning, the actuator will be detected for air leakage. When the air leakage of the actuator is detected, the valve position is held, and the "STATUS" led flashes twice every 2 seconds.

During the auto-tuning, user can press  key to exit and turn back to the previous operating mode.

After finishing the auto-tuning, press  key to exit and turn to the specific operating mode according to the previous operating mode. If the previous operating mode is automatic mode or manual mode, system turns back to the previous operating mode. If the previous operating mode is initial mode, system turns to the automatic mode.





NOTE !

- Although the positioner has ran the auto-tuning function in the factory. In order to get the control parameters of the actual work environment, the positioner must run the function again in the actual work environment.
- Make sure that the air supply pressure is in the working range of the actuator and has no big wave. Otherwise the auto-tuning may fail or the test parameters may be error.

5.3.2. Dead band setting

The function is used to adjust the valve position control accuracy. The system does not adjust the valve position when the gap between the current position value and the position set-point value is not bigger than the dead band value.





The minimum value of the dead band is 0.2%, and the maximum value of the dead

band is 5%. Nine blue led lights separately indicate nine dead band values of 0.2%, 0.4%, 0.6%, 0.8%, 1%, 2%, 3%, 4%, 5% from left to right. In the automatic mode, press  key for about 3 seconds to enter the dead band setting interface. One led light is flash in order to display the current dead band value. Press   keys to change the dead band value. And the value is displayed by the blue led flashing. Press  key to confirm and exit back to automatic mode interface. Press  key to exit back to automatic mode interface without change.



NOTE!

The smaller the dead band setting, the higher the control accuracy getting. Please set the dead band value in reason. Because the too small value may cause the solenoid valve in the body to act frequently and lead to long adjustment time and unstable working state.

5.3.3. Cut off function switch setting

The function is used to enable and disable the cut off function. In the initial or automatic mode, press  key for about 3 seconds to enter the setting interface. The blue led on the far left flashes to indicate that the cut off function is enabled, and the blue led on the far right flashes to indicate that the cut off function is disabled. Press  key to change. Press  key to confirm the change and exit. Press  key to exit without change.

5.3.4. Factory setting

The function is used to recovery the system to factory state. In the automatic mode, press  +  key for about 3 seconds to run the function. After finishing the function, system is in the initial mode, the dead band value is 1%, and the cut off function is enabled. Before matching between the positioner and the actuator, please make sure that the positioner is in the initial mode after starting up.

5.3.5. Input signal error detection

The function is used to detect the error of 4-20mA input signal. The error condition is the value of 4-20mA input signal $\leq 3.5\text{mA}$. Once detecting the error signal, "STATUS" led is flash. The single-acting power-off safe positioner will exhaust the actuator cylinder's air. The single-acting power-off freeze positioner will keep the valve (default) or close the valve position (according to customer needs). The double-acting positioner will leave the valve position in a free state.

5.3.6. Analogue signal output (optional)

The positioner outputs 4-20mA analogue signal in the automatic mode and the manual mode, and dose not output in the initial mode and the running state of the auto-tuning.

6. Trouble shooting

1. LED does not light after the positioner starting up.

Make sure that the 24V DC power supply is normal.

Make sure that the power cables are connected correctly.

2. The positioner is unable to locate position. The valve cannot be fully opened or fully closed for a long time.

Make sure that the pressure of air supply meets the requirement.

Make sure that the dead band value meets the situation that the valve position adjustment is stable and has no fluctuation.

Make sure that the pneumatic connections of the positioner and actuator are not leaking.

7. Attention

1. The power supply voltage of the positioner is 24V DC $\pm 10\%$. Please check the power supply before connecting the power cable to the electrical terminal. Make sure that the power supply is cut off before connecting the power cable. If the product is damaged by high voltage, it will lose warranty.
2. **Air supply use specification**
 - 1> The air pressure should be less than 0.7MPa.
 - 2> Install the filter pressure reducer (5 μm filtration accuracy) in front of the air supply inlet of the positioner to prevent moisture or oil from infiltrating. In the situation of much oil in the air, it is suggested to additionally install the oil separator (3 μm filtration accuracy) in front of the air supply inlet of the positioner. It is suggested to use the combination of SMC brand filter pressure reducer and SMC brand oil separator. Its model is AC20D-01CG-A. If the product is damaged due to the oil entering the product without oil separator or filter pressure reducer being installed, it will lose warranty.
3. After adjustment, the protective cover must be rotated tightly to ensure IP66 protection class. If the product is damaged by losing the protective cover or not rotating the protective cover tightly, it will lose warranty.

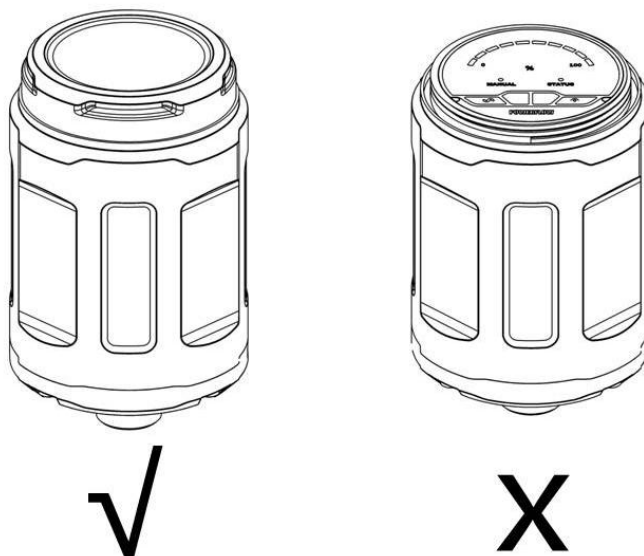

4. **Waterproof electrical connectors use specification**

- 1> The electrical connectors have foolproof design. Please connect the electrical female connector with the electrical male connector of the positioner according to the sign X2 and sign X3. Error connecting by strong force will destroy the electrical male connector.

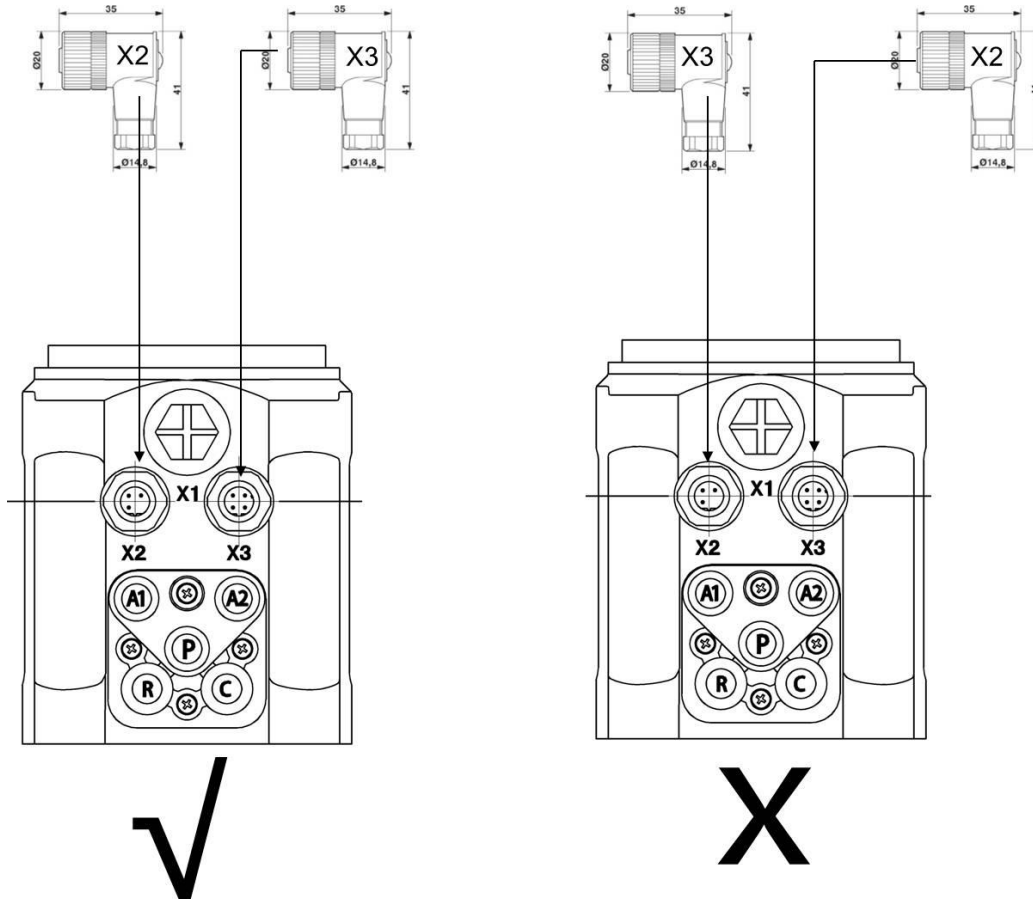

- 2> The cable diameter which is compatible with the waterproof electrical connectors is PG7 (4mm-6mm). Please use the multi - core cable with external insulation protection skin, otherwise the electrical connectors cannot achieve IP66 protection class.

Correct and error wiring ways are showing in the following pictures.

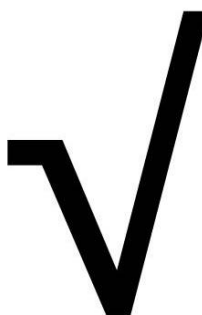

- 3> If the electrical male connectors are not used for a long time, to prevent water vapor or corrosive gases corroding the connector pins or entering the positioner inside, please screw on the electrical female connectors and block another side of the electrical female connectors with the silicone plugs. As shown below.

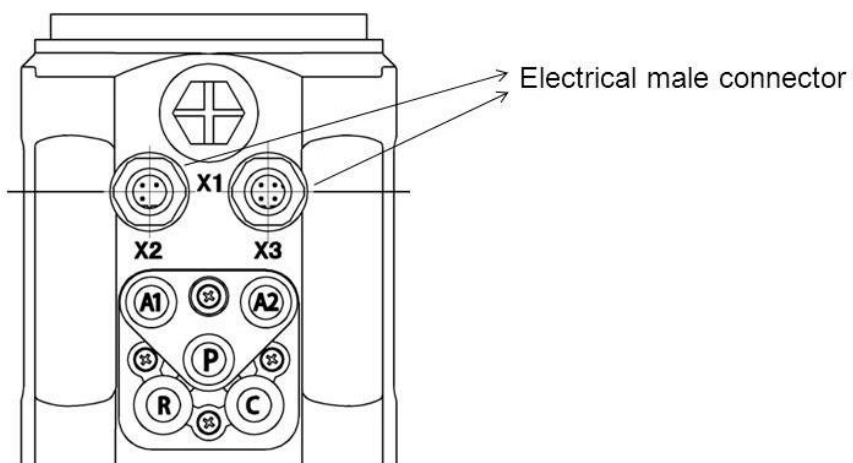

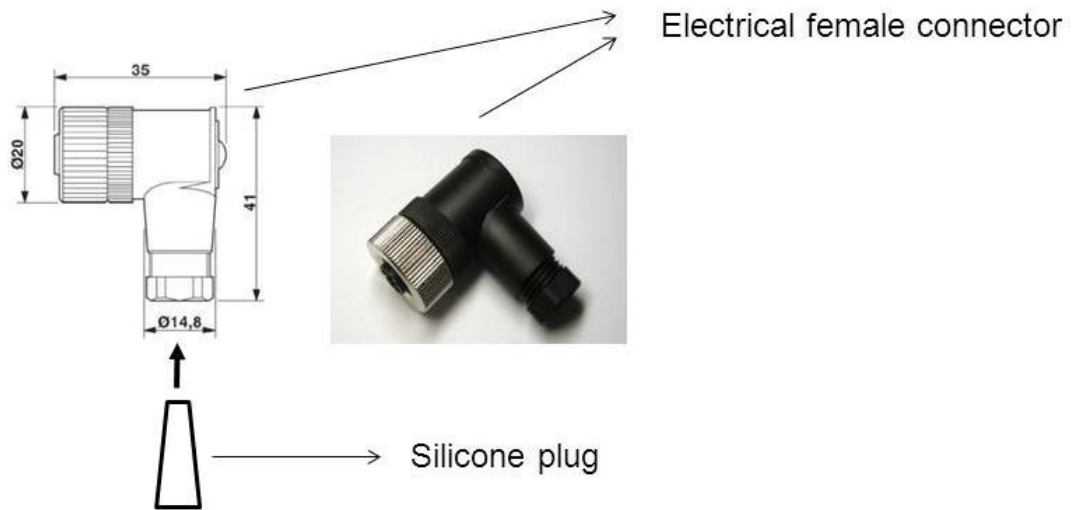

If the product is damaged by error operations for the waterproof electrical connectors, it will lose warranty.

5. If the product is damaged by the user removing the pneumatic connectors or the filter elements near the pneumatic connectors, it will lose warranty.
6. For matching the angle stroke actuator, make sure that the groove of the actuator axis is vertical, so that the connection between the actuator axis and the positioner sensor is suitable. Otherwise the radial load force will destroy the sensor. If the product is damaged by the above reason, it will lose warranty.

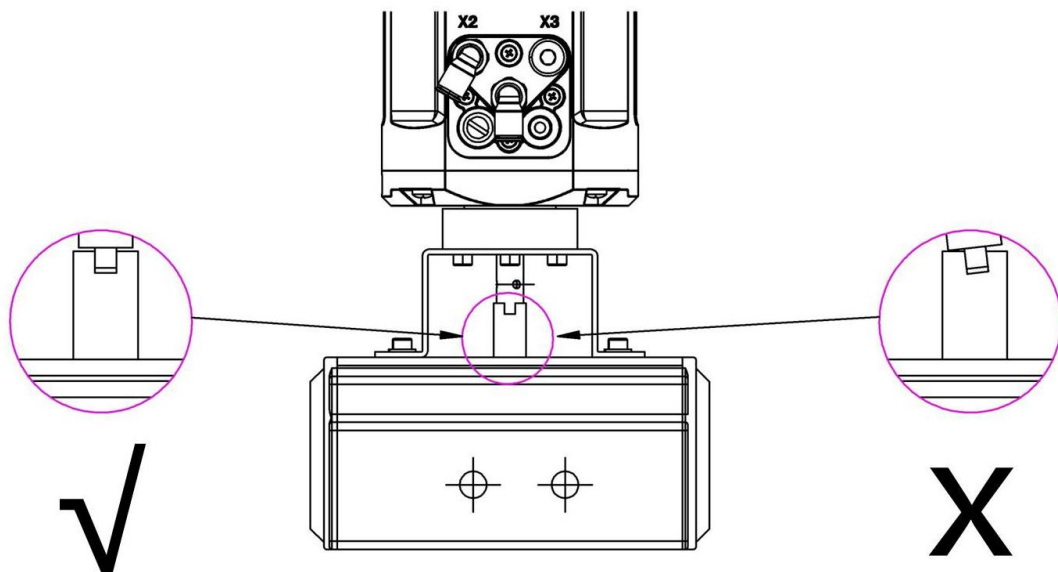

8. Warranty terms

1. If the product is found to have quality problems which are confirmed by our company staff, customers have after-sale services for product maintenance or free replacement in the warranty period. Service response time is 24 hours (excluding non-working days).
2. The warranty period of the product is based on the company's latest warranty policy, which is no less than 12 months after the sale.
3. The following situations for repaired product do not belong to the warranty range:
 - (1) The date is not in the warranty period.
 - (2) The product is disassembled without authorization and permit by the product company.
 - (3) The damage causes from the operation which is not according to the product instruction manual or other human factors. Including but not limited to:
 - 1> The product surface has collision scars.
 - 2> Error wiring or error power supply makes the product damaged.
 - 3> Parts and accessories are lost.
 - 4> The product is damaged due to the oil entering the product without oil separator or filter pressure reducer being installed.
 - 5> Losing the protective cover or not rotating the protective cover tightly makes the product damaged.
 - 6> Error using the waterproof electrical connectors makes the product damaged.
 - (4) Force majeure (natural disasters) causes product failure or damage.
4. According to the actual situation, the product company offers the free or fee-based maintenance services outside the warranty range.
5. The terms become effective since the two sides signed a supply contract.

9. Selection and ordering data

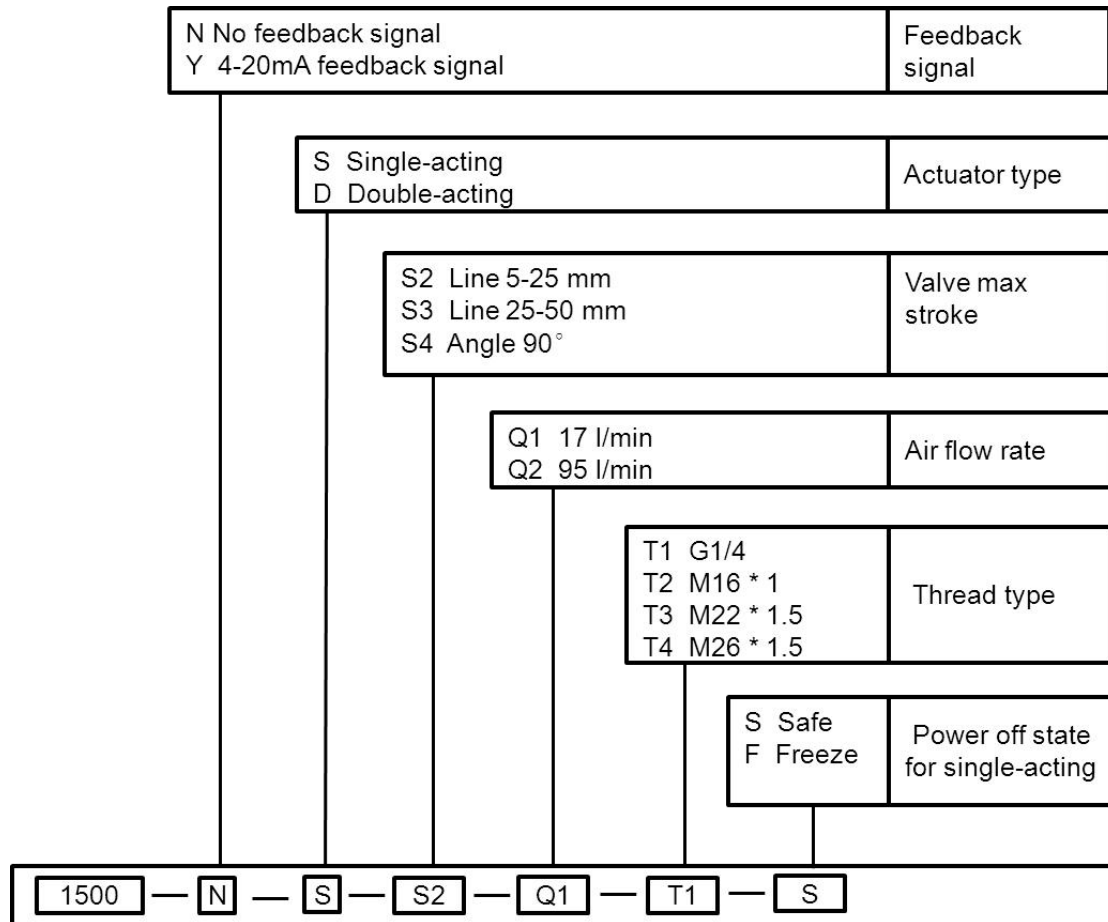

Remark:

In the **air flow rate** option, code Q1 is suggested to match the actuator of 40-100 mm internal gas chamber diameter, code Q2 is suggested to match the actuator of 125-160 mm internal gas chamber diameter. Code Q2 is only used for single-acting actuator, and only in **Freeze** state when power-off. The air flow rates for code Q1 and Q2 are under the condition of 0.6Mpa input pressure.

In the **valve max stroke** option, AT actuator range for code S4 is AT50~AT125. For other actuator models, please consult our company. It is no need to select the **thread type** option for code S4.

Power off state for single-acting option is **Safe** by default.

V251127

The changed contents of this manual are not noticed.

The Company reserves the final interpretation for related technical updating.

本说明书内容变更，恕不另行通知。

相关技术更新本公司保留最终解释权。

附件

智能阀门定位器气源要求

全系列产品

按照技术要求，全系列的智能阀门定位器气源要求为 3 级，提供符合气源要求的压缩空气，可以确保定位器的正常使用。

露点 3 级：露点为 -20°C 。（若定位器实际工作环境温度低于 -20°C ，则使用的压缩空气露点需相应低于定位器实际工作环境温度 -10°C ）

固体颗粒大小和密度 3 级： $5.0\text{mg}/\text{m}^3$ （对应粒径为 $5.0\mu\text{m}$ ），不允许有粒径大于 $5.0\mu\text{m}$ 的颗粒进入。

含油量 3 级： $1.0\text{mg}/\text{m}^3$ ，每单位立方米的空气累积油含量不超过 1.0mg 。

流程示例



图 1. 流程图

①在主管路中配备压缩空气干燥机，过滤掉压缩空气中产生的大部分水分，过滤后的压力露点可达到 -20°C ；

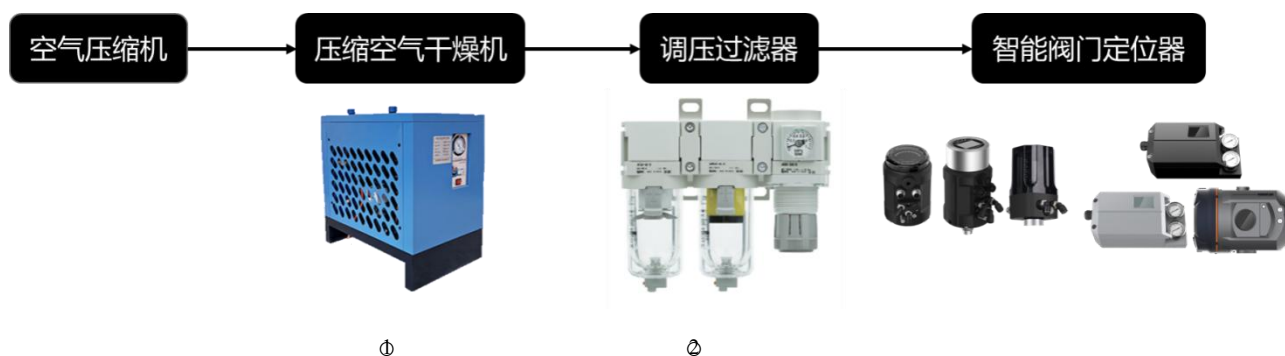

②选择任意与图 2 一致的调压过滤器组合安装在定位器管路的前端，安装时需过滤减压阀（空

气过滤器)在前,油雾分离器在后,要求过滤器过滤粒径在5.0um以上的颗粒,最高残余油含量 $\leq 1.0\text{mg}/\text{m}^3$ 。



图2. 调压过滤器组合

过滤器选型推荐

选型组合	<p>空气过滤器 + 油雾分离器 + 减压阀</p> <p>AF AFM AR</p> 	<p>过滤减压阀 + 油雾分离器</p> <p>AW AFM</p> 
	<p>AC 30 C- [] 03 DG - [] - [] - A</p> <p style="text-align: center;"> 1 2 3 4 5 6 </p>	<p>AC 30 D- [] 03 DG - [] - [] - A</p> <p style="text-align: center;"> 1 2 3 4 5 6 </p>
选型编号	SMC AC20C-02G-A	<p>SMC</p> <p>AC20D-02G-A SMC</p> <p>AC30D-02G-A</p>

	入口侧压缩空气质量略低于定位器使用要求时	入口侧压缩空气质量符合定位器使用要求时	
基础参数	流体：空气 环境温度及使用温度：-5~60°C（未冻结） 耐压：1.5MPa 使用压力范围：0.05~1.0MPa 设定压力范围：0.05~0.7MPa 过滤精度：AW:5um、AFM：0.3um（捕集效率 99.9%） 杯体材质：聚碳酸酯 结构：溢流型		
选型参数	①主体尺寸：20 额定流量：200L/min 杯体保护罩：标准（钢带） 质量：0.39kg ②螺纹种类（无记号）：Rc ③接口管径 02：1/4 ④无记号：手动排水器 压力表 G：圆形压力表（带限位指示器） ⑤无记号：无附件 ⑥无记号：无特殊选择	①主体尺寸：20 额定流量： 150L/min 杯体保护罩：标准 （钢带） 质量：0.33kg	①主体尺寸：30 额定流量： 330L/min 杯体保护罩：标准 装备（聚碳酸酯） 质量：0.66kg
		②螺纹种类（无记号）：Rc ③接口管径 02：1/4 ④无记号：手动排水器 压力表 G：圆形压力表（带限位指示器） ⑤无记号：无附件 ⑥无记号：无特殊选择	
1 系列定位器*	●	●	/
IP 系列定位器*	●	/	●

*●为推荐的选择

注：过滤器处理空气额定流量需大于定位器的最大工作流量，在同一串联管路上存在多台定位器时则最大工作流量需相加计算（1系列最大流量 1500、1600： Q1-17L/min； Q2-95L/min； 1880S： 17L/min IP系列最大流量 IP5500: 155 L/min； IP6000/IP6500:187 L/min； IP6000d: 150 L/min 以上数据均为 0.6MPa 下测量所得）。

注意事项

1. 应视工况要求选择不同性能的调压过滤器，避免因工作环境的高温、低温、高压、腐蚀等原因导致调压过滤器失效,详见末尾附录选型表。
2. 定期巡查过滤器的使用情况，若使用频繁的工况应提高巡查次数，避免因过滤器滤芯堵塞导致的故障问题（故障举例：①过滤失效，导致定位器进入异物，致使定位器故障；②滤芯堵塞，导致气源供应异常，定位器无法正常工作等）。
3. 采用自动排水功能的调压过滤器需要避免排水孔的堵塞，定期巡查可避免过滤器故障导致滤杯内大量积水。手动排水的应视工况下过滤器的积水速率，定时人工排水。
4. 按照调压过滤器的使用说明，定期维护或更换不合格的产品，可避免不必要的故障出现。