

智能阀门定位器

1880S 系列使用说明书

(安装使用前请仔细阅读使用说明书)



使用说明书目录

1880S 系列智能阀门定位器

1. 概述	1
1.1. 产品结构	1
1.2. 产品描述及应用	2
2. 安装说明	3
2.1. 外形尺寸	3
2.2. 与执行器组装	4
2.3. 操作界面角度调整	6
3. 接口说明	8
4. 技术参数	10
4.1. 工作参数	10
4.2. 电气参数	10
4.3. 机械参数	10
4.4. 气动参数	11
5. 操作	11
5.1. 界面描述	11
5.2. 工作模式和工作界面	13
5.3. 主菜单	14
5.3.1. 输入信号	15
5.3.2. 自整定	15
5.3.3. 附加功能	17
5.3.3.1. 特性曲线	17
5.3.3.2. 紧闭功能	21

5.3.3.3. 信号方向	23
5.3.3.4. 行程限制	24
5.3.3.5. 死区设置	26
5.3.3.6. 安全位置	27
5.3.3.7. 输出设置（可选）	27
5.3.3.8. 信号错误	28
5.3.3.9. 用户校正	29
5.3.3.10. 手动速度	32
5.3.3.11. 密码保护	33
5.3.3.12. 出厂设置	34
5.3.4. 界面语言	34
6. 问题排除	35
7. 注意事项	35
8. 保修条款	38
9. 选型及订货数据	40

1. 概述

1.1. 产品结构



图 1. 定位器结构

1.2. 产品描述及应用

1880S 系列智能电气阀门定位器是一款基于微处理器的阀门开度调节器。阀门开度可通过外部输入信号设定。定位器运用自动控制算法和 PWM 控制技术，快速而准确地实现阀门的开度调节，从而来控制流体管路的流量。

定位器可以与各种气动阀组合使用。如图 2 所示。

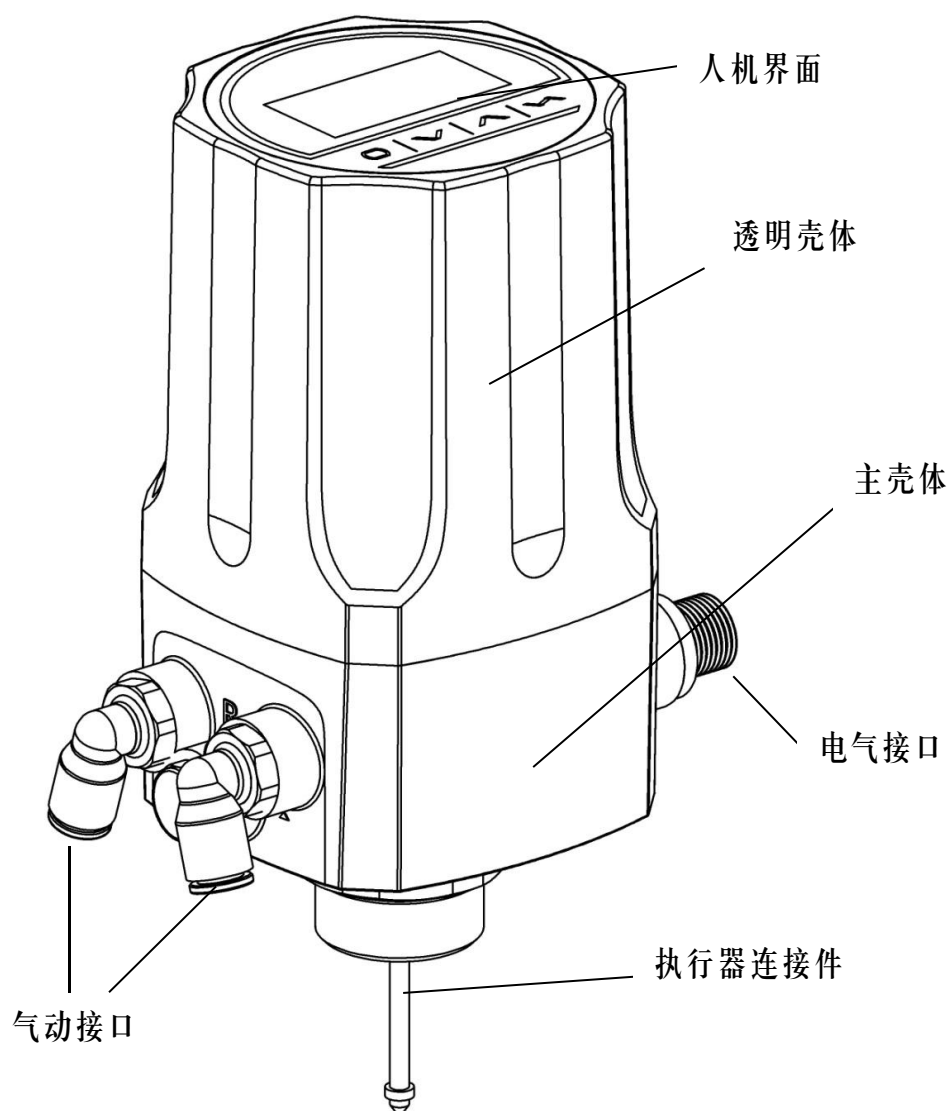

与隔膜阀组合



与角座阀组合

图 2. 定位器与气动阀组合

该产品可在密封空间中使用，并实现远程自动控制。它具有传输特性，安全位置，紧闭等多种辅助功能。同时它容易安装，操作和维护，并且故障率低。

2. 安装说明

2.1. 外形尺寸



图 3. 外形尺寸

2.2. 与执行器组装

1. 确认执行器阀门行程值和执行器顶部螺纹规格是否相符。
2. 阀门处于完全关闭和完全打开状态时，用深度尺分别测量执行器阀杆顶端到执行器顶部安装基准面的距离 C1 值和 C2 值（图 4 中标注所示），并记录。

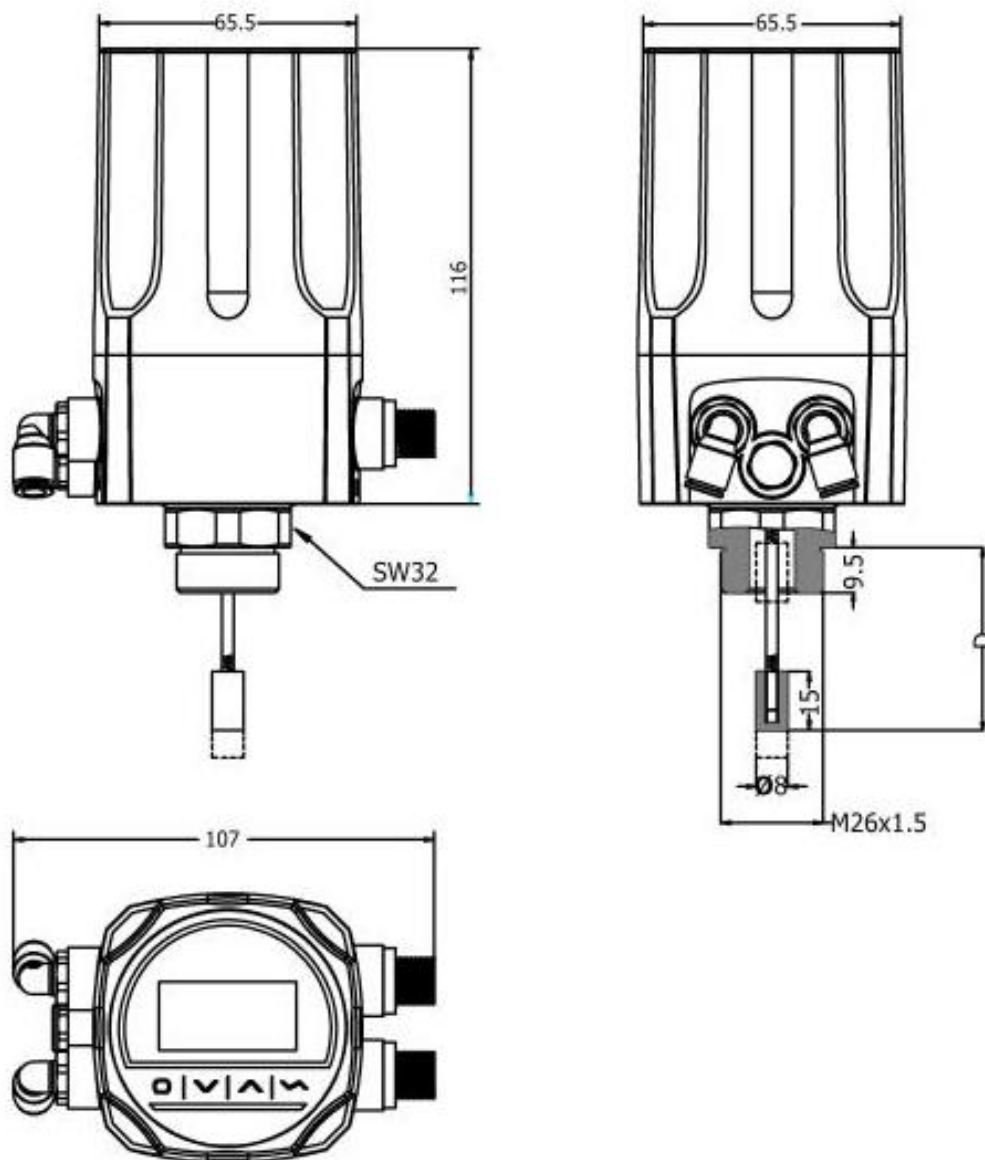

图 4. 执行器测量

3. 调节位移传感器的调节螺母，然后在位移传感器完全松开状态下用深度尺测量 D 值（图 5 中标注所示）。计算压缩量 $L1 = D - C1$ ， $L2 = D - C2$ 。建议尽可能使 L1 和 L2 的值在表 1 所示的参考范围内。如果 L1 或 L2 的值无法满足在表 1 所示的参考范围内，则可根据实际情况调节 D 值。

注意!

调节的 D 值必须保证使 $L1 > 0$ ， $L2 <$ 位移传感器最大压缩量。否则将无法匹配。

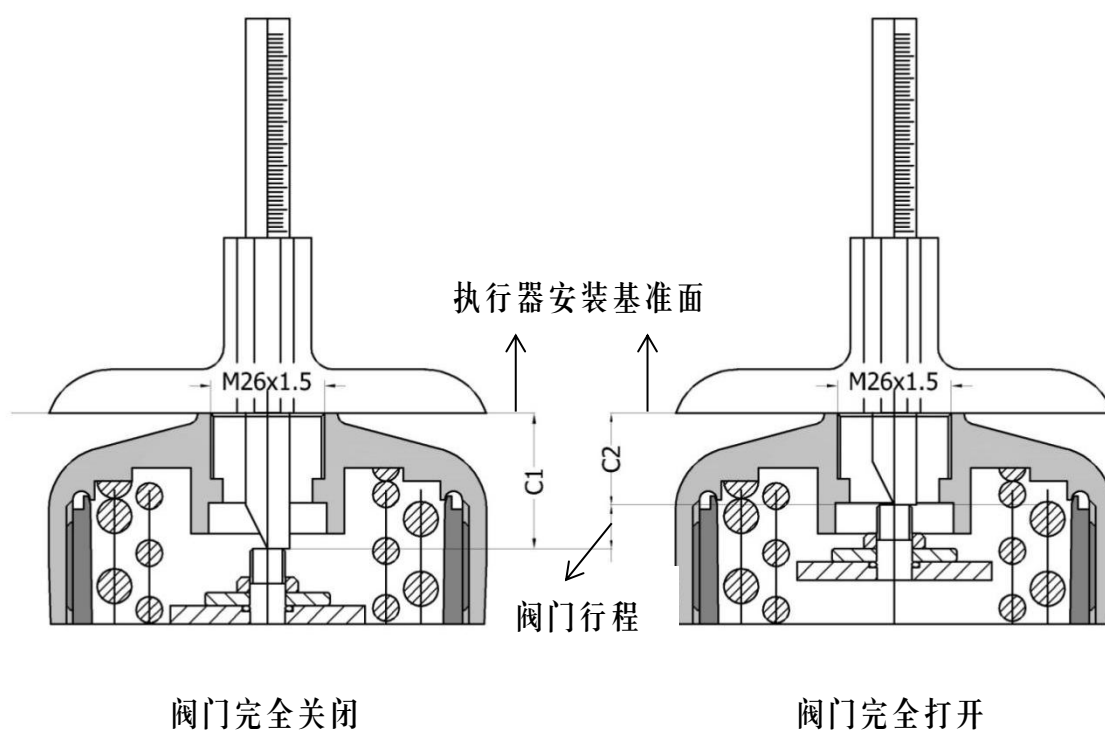
阀门最大行程	D 值范围	压缩量 L1, L2 参考范围
5~25 mm	45~51 mm	3~28 mm

表 1. 压缩量参考范围



图 5. 位移传感器调节和测量

4. 将执行器内部阀杆升到最高位置,用 32 号扳手将定位器底部的执行器连接组件右旋入到执行器对应螺纹接口,并确保旋紧连接组件。如图 6 所示。

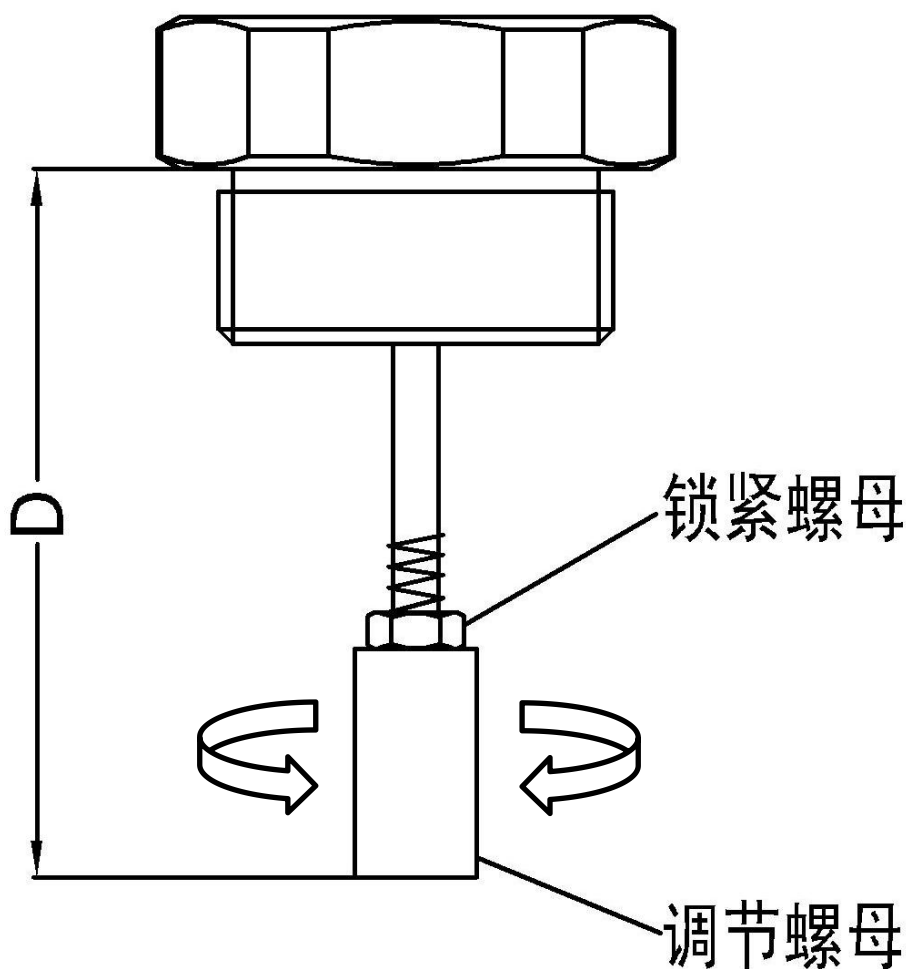

图 6. 定位器与执行器组装

2.3. 操作界面角度调整

将定位器与阀门连接之后，定位器可与阀门之间做角度调整。若需要调整定

位器操作界面角度，可以顺时针或逆时针 180° 范围内旋转主壳体到需要的角度。

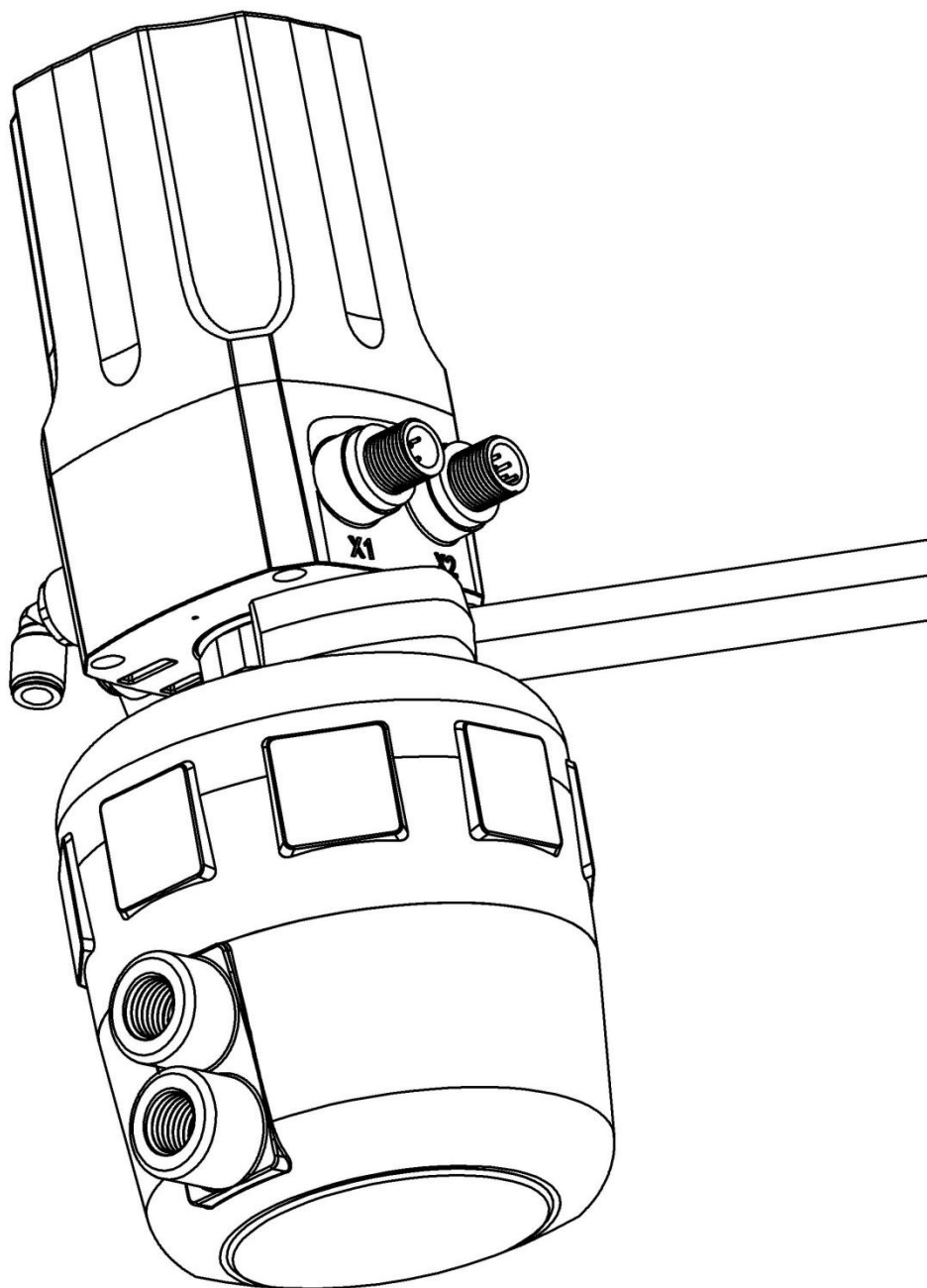

图 7. 调整操作示意图

3. 接口说明

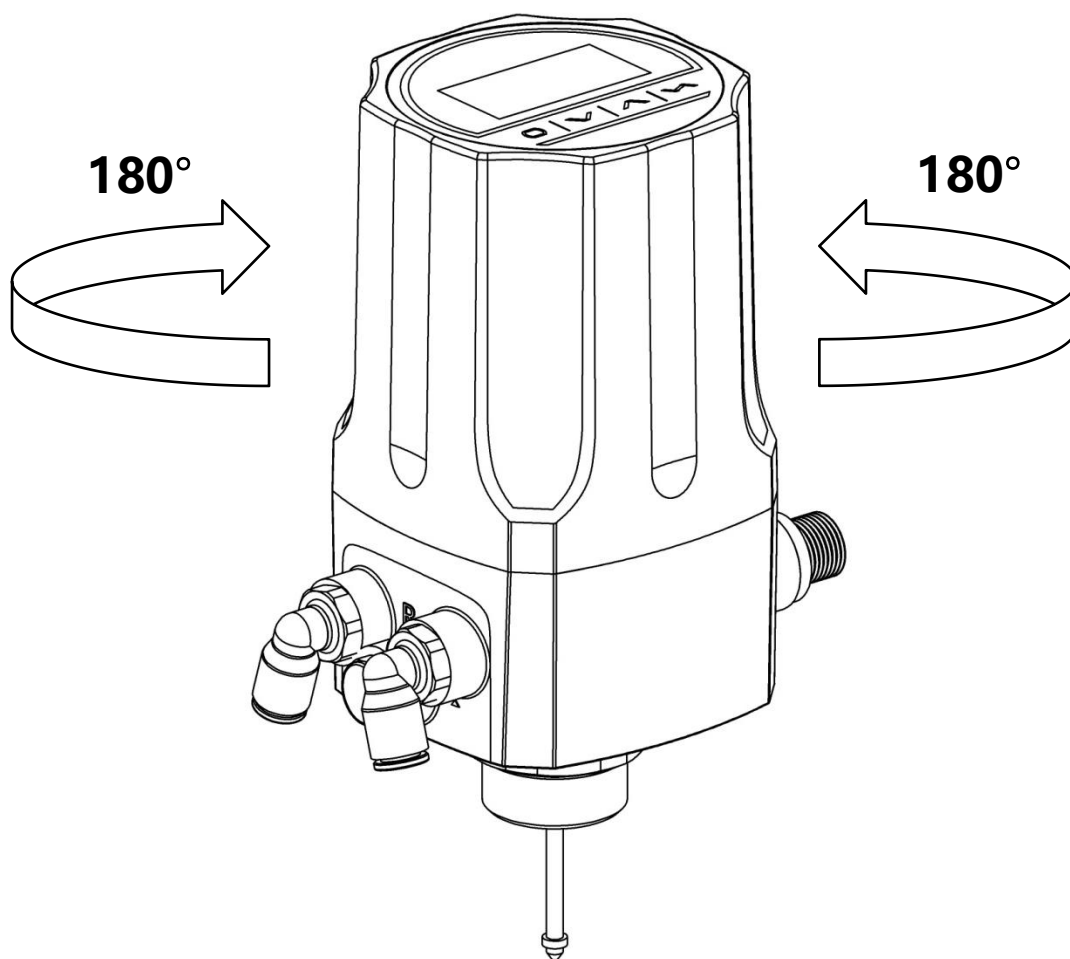

图 8. 接线端子

端口标注	端子号	描述	信号类型
X1	1	模拟信号输出 +	0/4 – 20 mA
	3	模拟信号输出 GND	GND

表 2. X1 电气端子 (可选)

端口标注	端子号	描述	信号类型
X2	1	电源 +	+24 V
	2	电源 GND	GND
	3	设定信号输入 +	0/4 – 20 mA
	4	设定信号输入 GND	GND

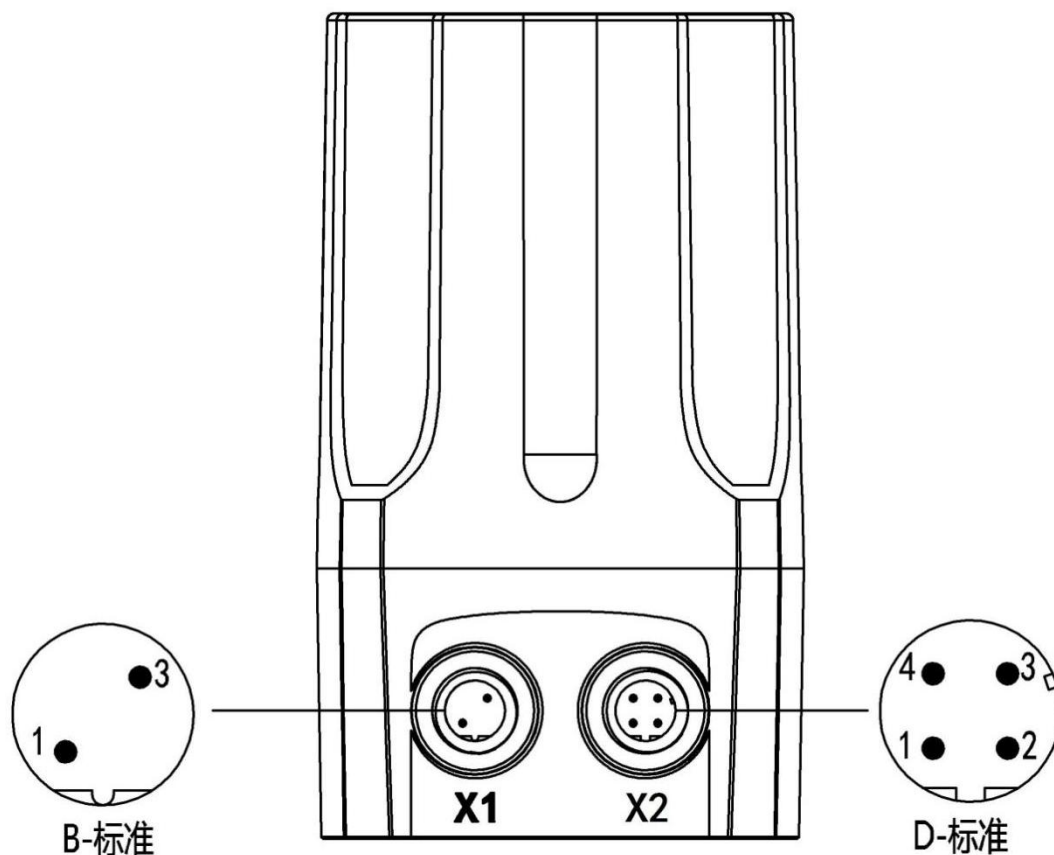
表 3. X2 电气端子

注意!

电气线缆端子接错将可能导致定位器损坏。

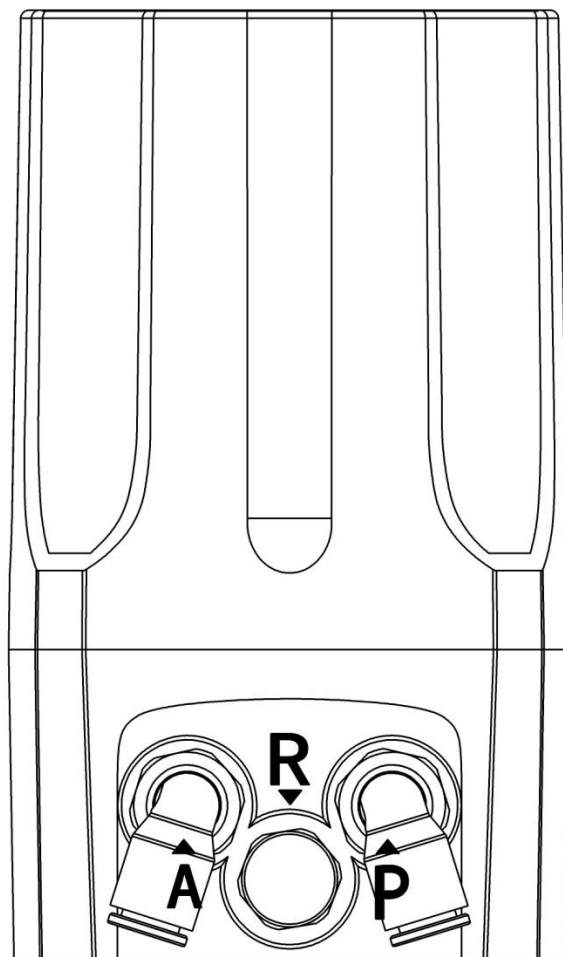

端口标注	描述
P	气源进入 (内置滤网, 过滤尺寸 20 μm)
R	排气
A	先导气口

表 4. 气动端子

注意!

气源压力超过 7 bar 可能导致定位器损坏。

4. 技术参数

4.1. 工作参数

环境温度：0~60℃

防护等级：IP67

抗振参数：100Hz

4.2. 电气参数

连接器件：电缆密封接头

供电电源：24 V DC \pm 10 %， \geq 1A。推荐使用开关电源。

功耗：<5W

设定信号输入阻抗：120 Ω

模拟输出信号：最大负载 560 Ω

4.3. 机械参数

上盖材料：聚碳酸脂（PC）

密封材料：硅橡胶(SI)

主体材料：聚酰胺(PA6-GF30)

控制行程范围：5~25 mm

4.4. 气动参数

气源压力范围：3~7 bar，具体值视执行机构而定

气动接口规格：1/4 英寸插入式软管接头

气源质量要求：符合 ISO 8573-1

固体颗粒大小和密度 3 级

露点 3 级

含油量 3 级

输出气体流量：17L/min（输入压力为 0.6Mpa）

5. 操作

5.1. 界面描述

定位器包括了 4 个按键和两个显示屏。主显示屏位于壳体正上方。用户可通过 4 个按键来切换主显示屏上的显示界面和设定参数。主显示屏最下方的显示用来描述对应按键的功能配置。副显示屏位于壳体侧边，方便用户从侧边查看阀位值。



图 9. 主显示屏和按键



图 10. 副显示屏

5.2. 工作模式和工作界面

定位器有两种工作模式：自动模式和手动模式。定位器开机时默认运行在自动模式下。此时界面处于锁定状态，如需要操作界面，需要同时长按左右两个“解锁”键 3 秒解锁。

在自动模式下，定位器接收作为设定值的输入信号，并自动调节阀门开度。

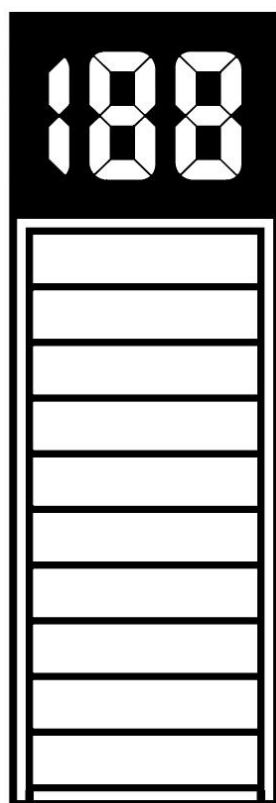
在手动模式下，用户必须操作+/-按键手动调节阀门开度。手动调节完阀门开度后或自动模式转手动模式后，当前位置值作为设定值，并在手动模式界面上显示。

如果开关量信号输入功能没有被使能用于切换工作模式，工作模式的切换将通过屏幕上的“自动”和“手动”按键。如果使能了开关信号用于切换，按键切换将不起作用。

用户可通过按键切换工作界面。工作界面描述如表 5 所示。在工作界面下，当长时间不按按键时，界面会自动锁定。如要解锁，同时长按左右两个“解锁”键 3 秒。在锁定界面下，当长时间不按按键时，显示屏显示屏保界面。按任意键可退出屏保界面。

显示	描述
	<p>自动模式下当前阀位值。按“位置”键或“自动”键显示。</p>
	<p>自动模式下输入信号值。按“输入”键显示。</p>



	<p>自动模式下设定值。按“设定”键显示。</p>
	<p>手动模式下当前阀位值（大字体）和阀位设定值（小字体）。按“手动”键显示。</p>
	<p>屏保界面，显示阀位值。自动模式下显示光标。</p>

表 5. 工作界面

5.3. 主菜单

在主菜单下，用户可以操作具体功能或设置具体参数。用户操作完具体功能或设置完具体参数后请从主菜单退出到工作界面。如果长时间不操作菜单，系统会自动从菜单界面退出到自动模式锁定界面。

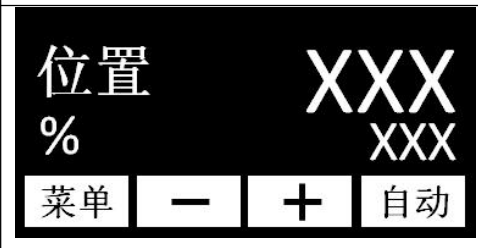

图 11. 主菜单操作结构

5.3.1. 输入信号

此选项是用来选择用于作为设定值的输入信号的类型。恢复出厂设置后为 4-20mA。

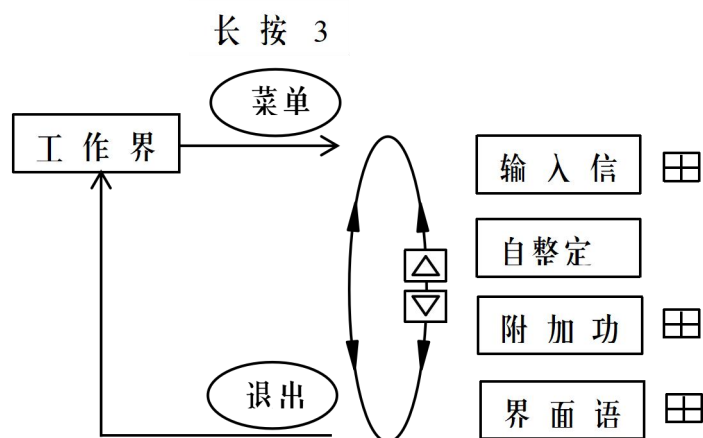

图 12. 输入信号操作结构

5.3.2. 自整定

自整定功能能够自动测量定位器的相关控制参数。包括行程方向；阀门行程范围；控制电磁阀的 PWM 参数。正常运行情况下整个过程将会持续 2-3 分钟。

自整定运行过程中会同时检测阀门行程是否超出位移传感器有效行程范围。当检测到阀门行程超出位移传感器有效行程范围时，如果阀门行程最小值小于位移传感器有效行程范围最小值时，屏幕显示“位置最小值错误”；如果阀门行程最大值大于位移传感器有效行程范围最大值时，屏幕显示“位置最大值错误”。

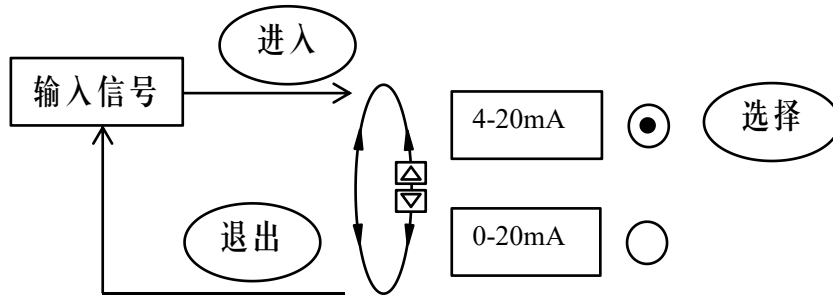
如果屏幕显示以上错误信息，用户需要对定位器和执行器重新匹配。详见第二章。



图 13. 自整定操作结构

注意!

- 虽然在出厂前已进行过自整定,但是为了能获得工作环境下的控制参数。用户还是必须在实际工作环境下对定位器执行自整定操作。
- 在自整定过程中,确保气源压力在执行器工作的压力范围内并且没有大的波动,否则可能导致自整定参数出错或自整定失败。

5.3.3. 附加功能

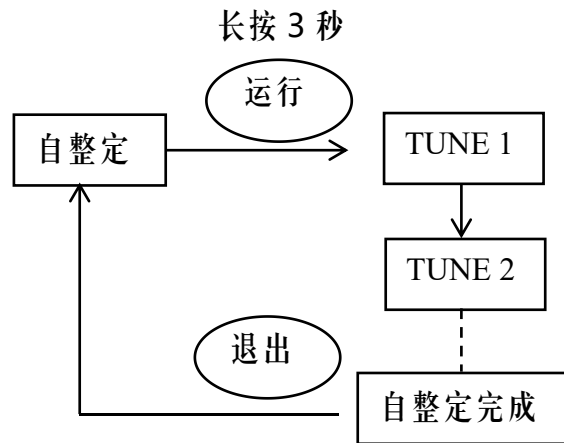

图 14. 附加功能操作结构

5.3.3.1. 特性曲线

出厂设置:

特性曲线选项：线性

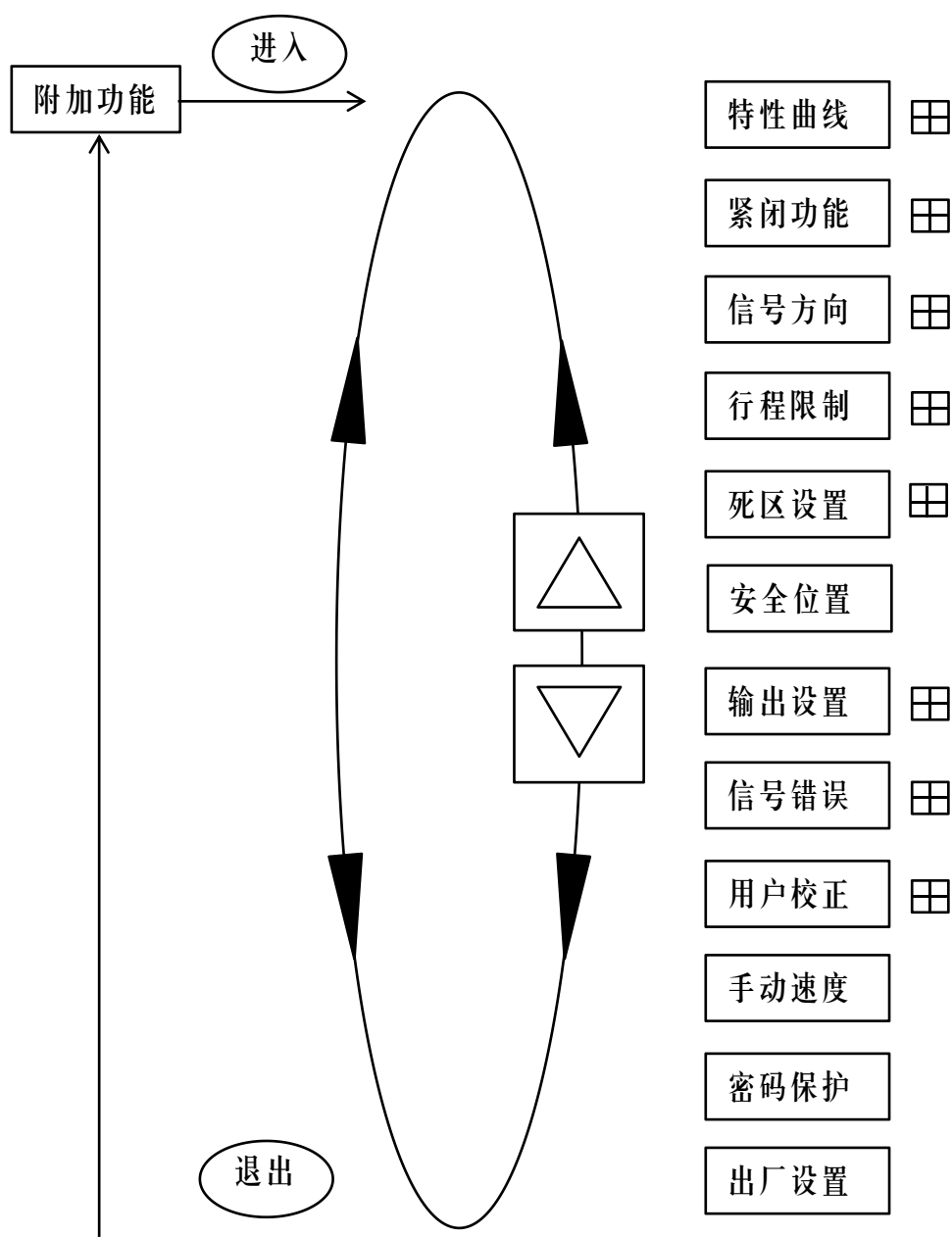
等百分比类型选项：1:25

自定义参数：0%，5%，10%……95%，100%

特性曲线是阀位设定值与阀门行程的转换关系。在实际控制系统中，通常要求使被控量具有特定的控制特性（比如线性）。用户可以通过在功能菜单中选择和设置相应的特性曲线来达到控制要求。



图 15. 线性和等百分比特性



图 16. 特性曲线操作结构

选项	描述
线性	位置设定值与阀门行程为 1:1 转换关系。
等百分比	位置设定值与阀门行程为等百分比转换关系。
自定义	用户自定义位置设定值与阀门行程的转换关系。

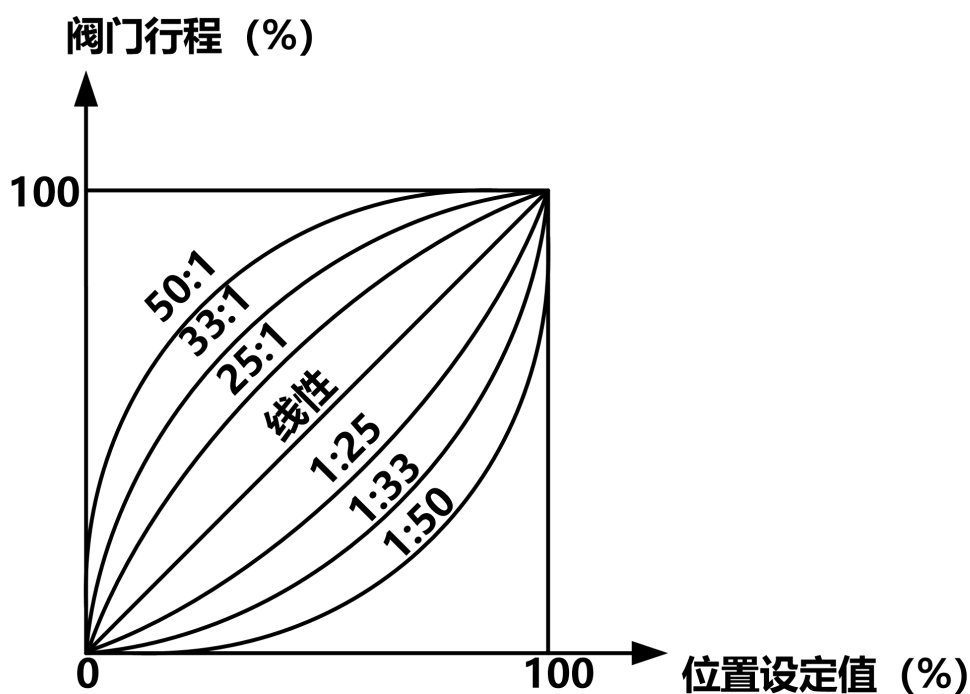
表 6. 特性曲线选项

等百分比特性

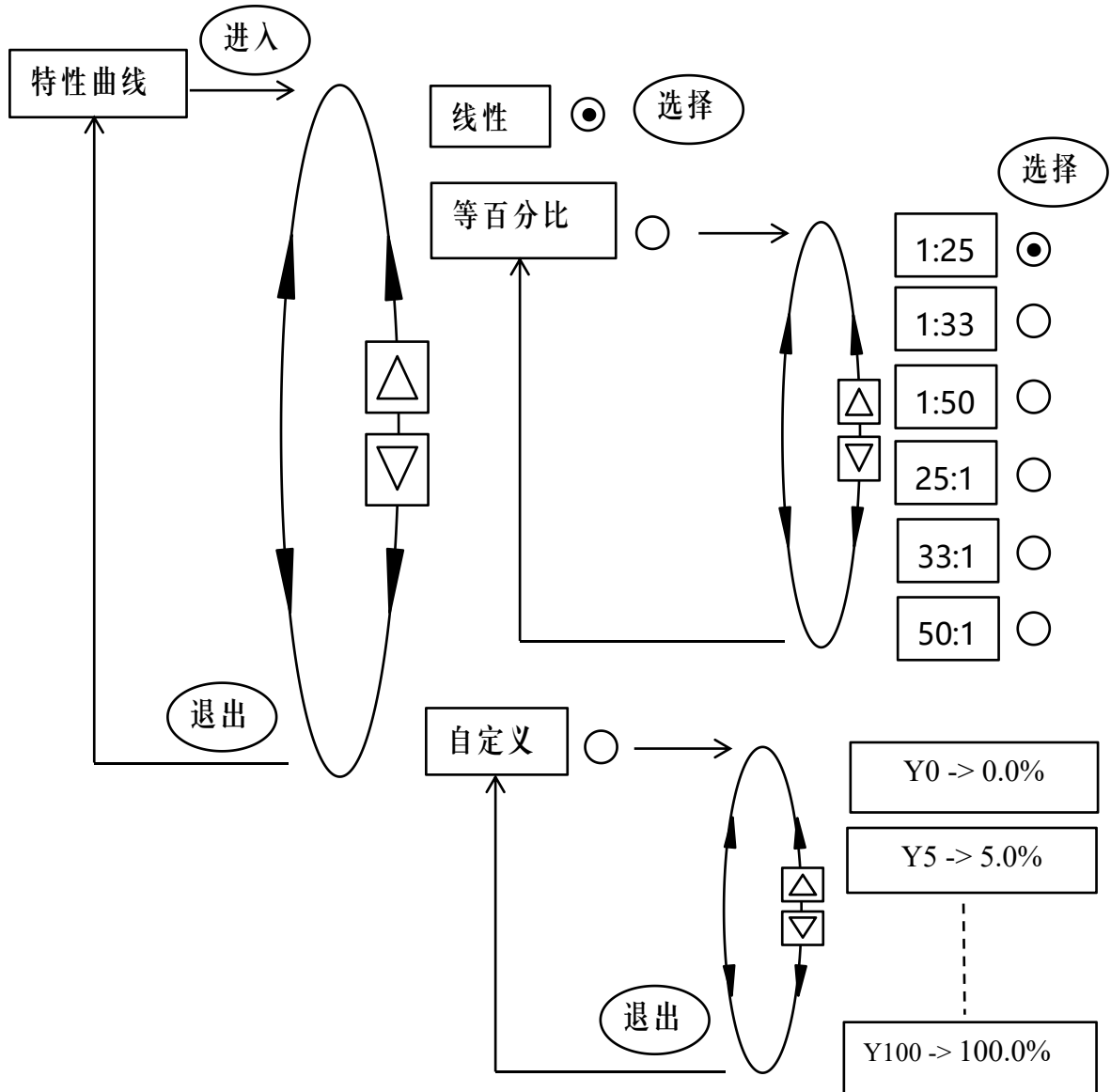
等百分比特性选项包括 1:25, 1:33, 1:50, 25:1 (反向), 33:1 (反向), 50:1 (反向)。

自定义特性

用户能通过操作自定义选项来编辑自定义特性。

将 0-100% 的设定值范围等间隔分为 21 个设定点。每个点上都可设置行程范围为 0-100% 的值。



图 17. 自定义操作结构



图 18. 自定义特性曲线示意图

5.3.3.2. 紧闭功能

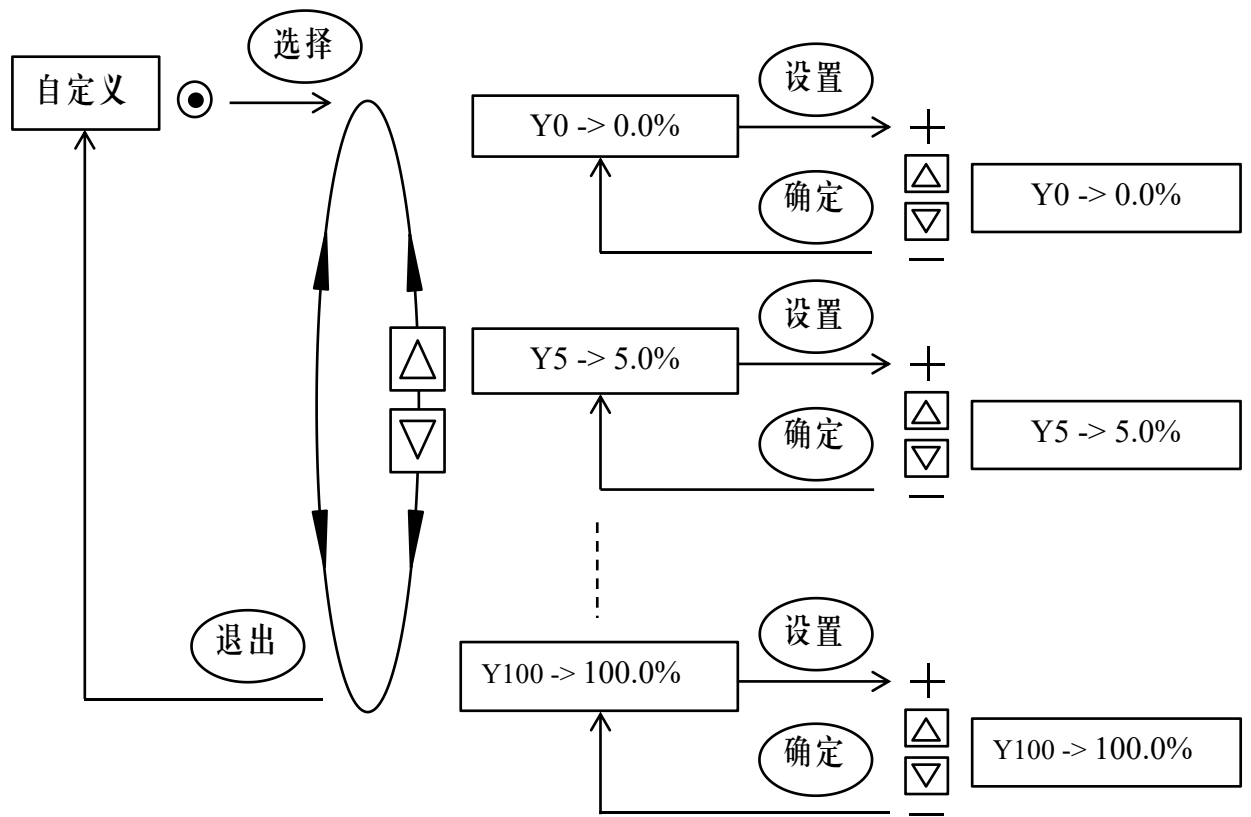
出厂设置：

自动紧闭最小值 1%，最大值 99%

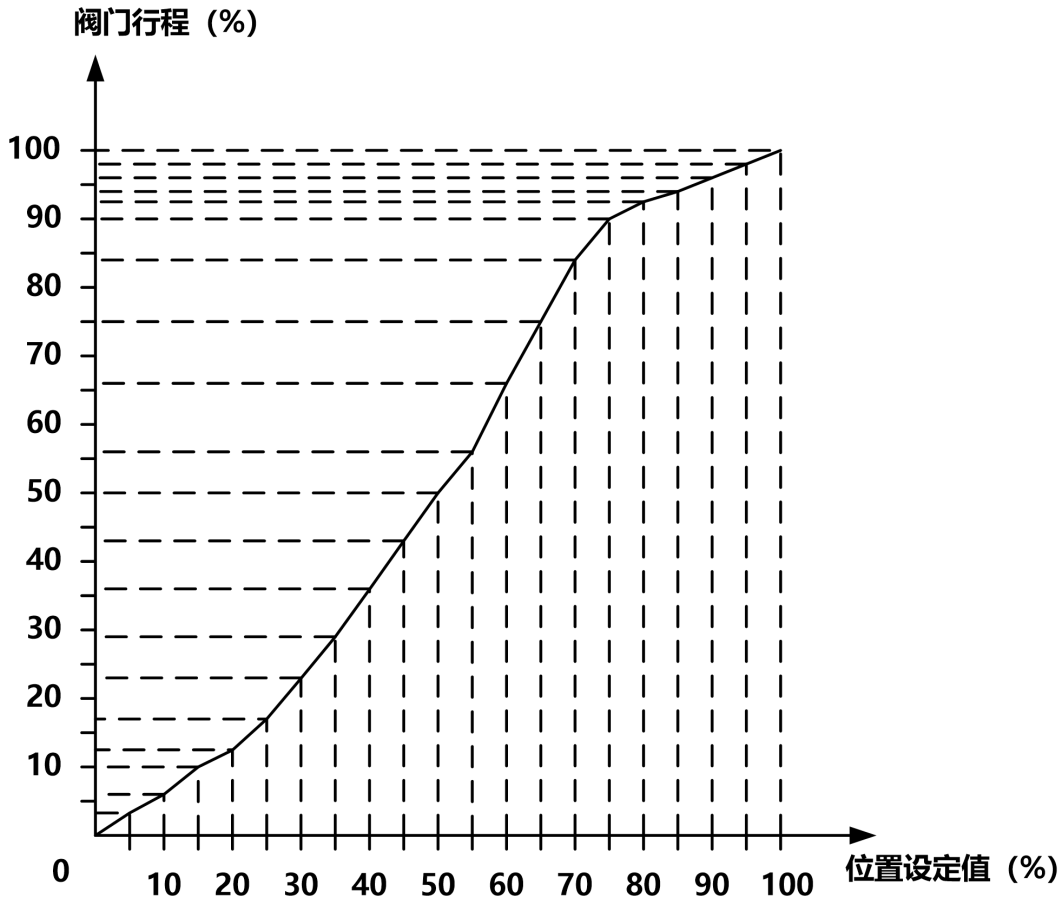
手动紧闭最小值 2%，最大值 98%

当设定值百分比在紧闭功能使能范围内时，阀门执行完全进气或完全排气操作。当设定值百分比小于等于紧闭最小值时，阀门完全关闭；当设定值百分比大于等于紧闭最大值时，阀门完全打开。

紧闭功能分为自动紧闭和手动紧闭，分别用于自动模式和手动模式下。紧闭

最小值设置范围：0-25%，紧闭最大值设置范围：75-100%。当紧闭功能使能后，工作界面会显示“cut off”标志。

在自动模式下，最小值为 0%时，关阀门紧闭不使能；最大值为 100%时，开阀门紧闭不使能。

定位器在执行紧闭操作时，由于阀门执行机构内部特性，阀门全闭或全开时的阀位会产生一定的偏差。在阀门全闭时，阀位值可能小于 0；在阀门全开时，阀位值可能大于 100。



图 19. 紧闭功能操作结构



图 20. 紧闭功能示意图

5.3.3.3. 信号方向

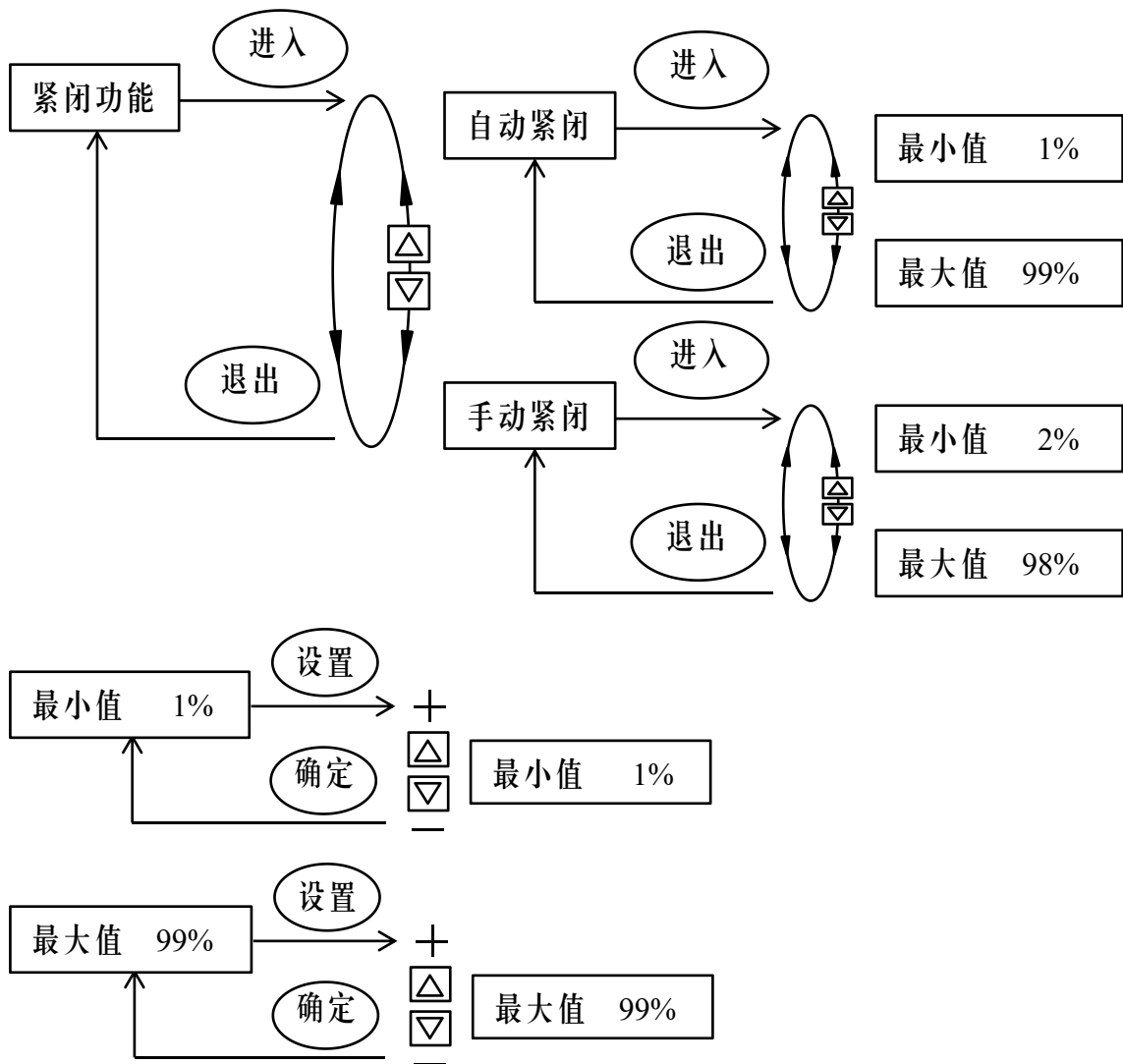
出厂设置：

信号方向选项：上升

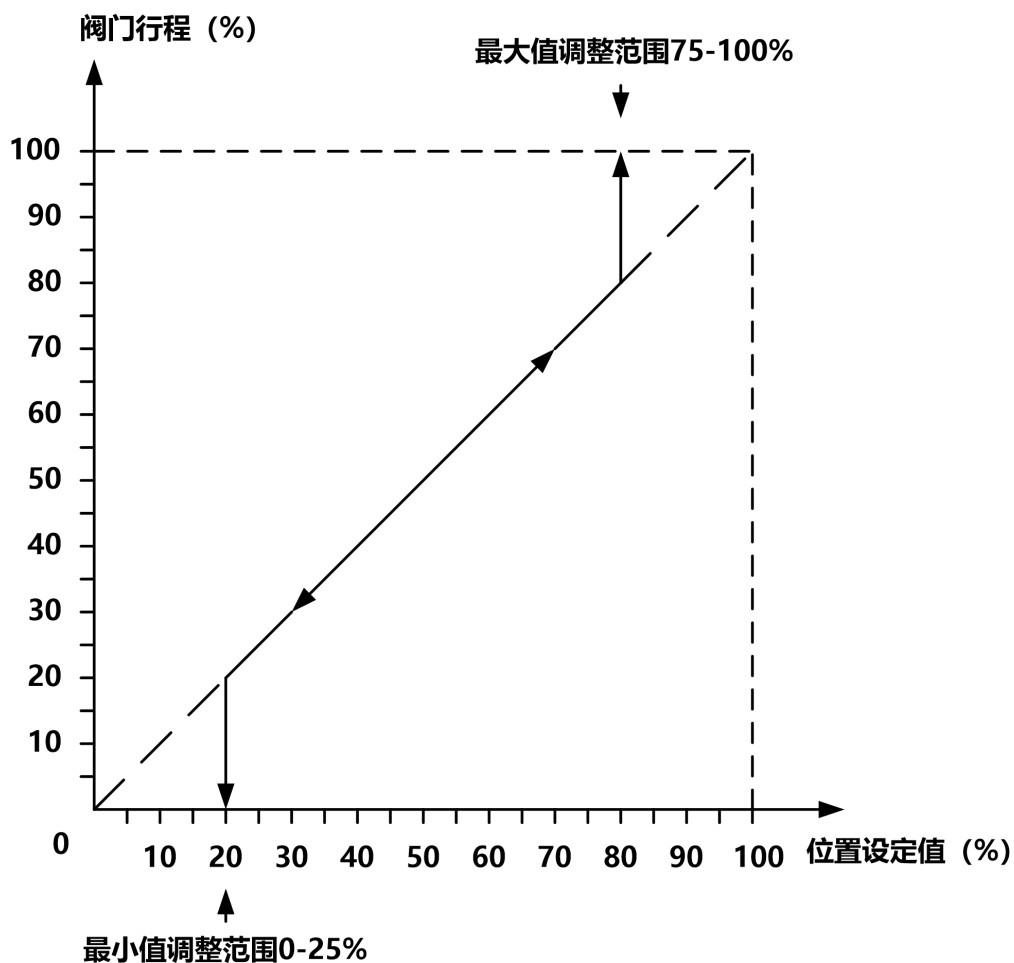
此功能用来设置模拟输入信号与设定值之间的对应关系。

上升：0/4 mA → 0%, 20 mA → 100%

下降：0/4 mA → 100%, 20 mA → 0%



图 21. 信号方向操作结构



图 22. 信号方向示意图

5.3.3.4. 行程限制

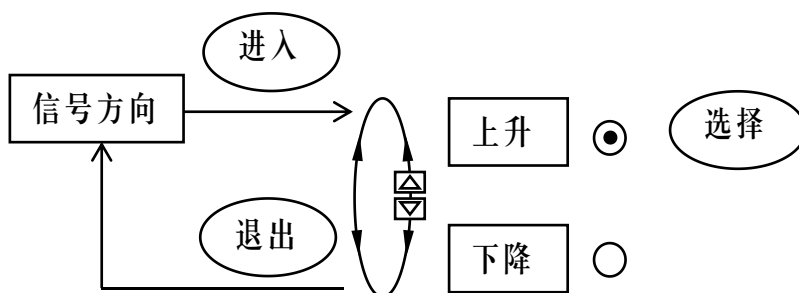
出厂设置：

最小值 0% （无限制）

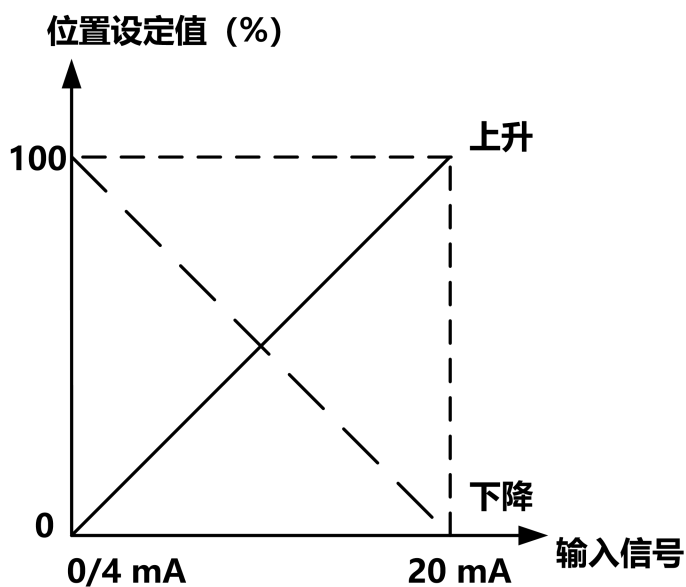
最大值 100%（无限制）

此功能限制了在物理行程范围内的自动调节范围。当设置了行程限制后，阀位显示值可能大于 100%或小于 0%。

最小值调整范围：总物理行程的 0-50%。

最大值调整范围：总物理行程的 50-100%。

最小最大值之间最小差值为总物理行程的 50%。



图 23. 行程限制操作结构



图 24. 行程限制示意图

注意!

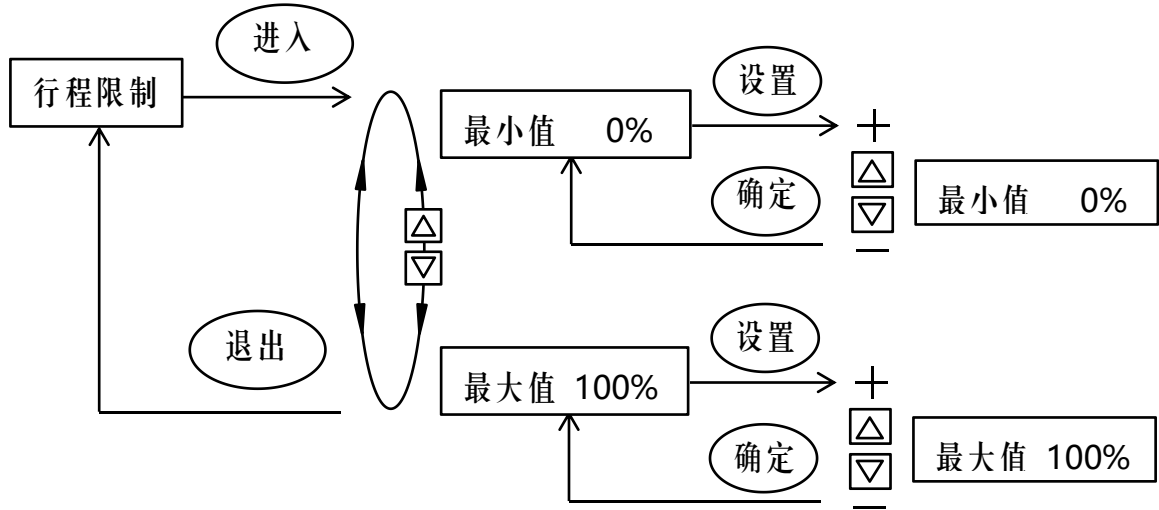
死区设置的越小，所获得的精度越高。请合理设置此值。因为过小的值可能使电磁阀频繁动作，导致长的调节时间和运行不稳定。

5.3.3.6. 安全位置

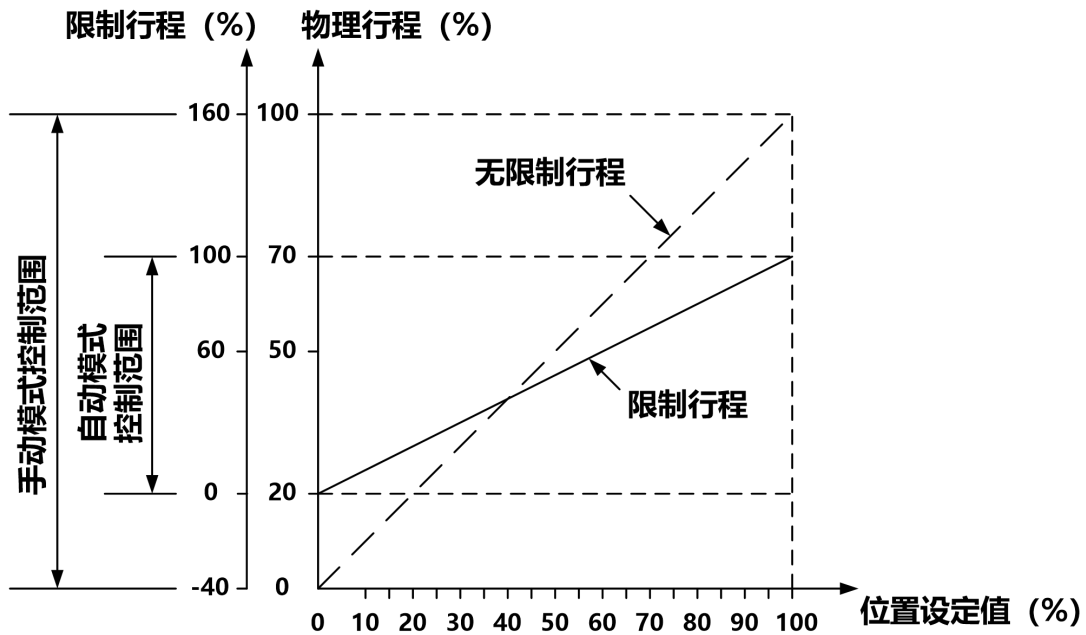
出厂设置:

安全位置值: 0%

此功能设置一个安全位置用于一些特定情况下阀门调节到此位置。阀位是否调节到安全位置可以通过开关输入信号或者判断设定值输入信号是否正确来控制。当阀位调节到安全位置被使能后，工作界面会显示“safe pos”标志。



图 26. 安全位置操作结构

5.3.3.7. 输出设置（可选）

出厂设置:

模拟输出选项: 位置输出

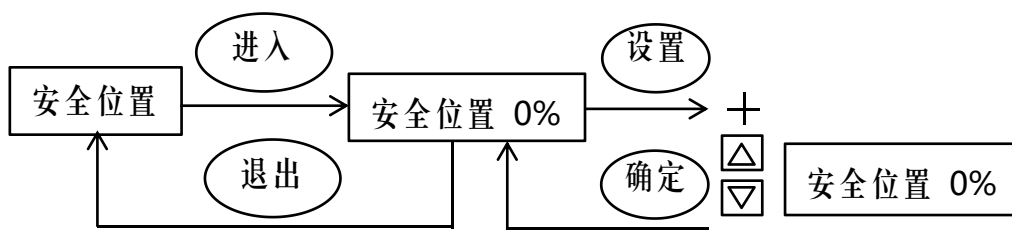
模拟信号类型选项: 4-20mA

当前阀位值或设定值用模拟量信号做为反馈信号输出。模拟量信号类型有 4-20mA, 0-20mA 二种可选。如果产品选型选择无反馈信号，此功能无效。



图 27. 输出设置操作结构



图 28. 信号类型操作结构

5.3.3.8. 信号错误

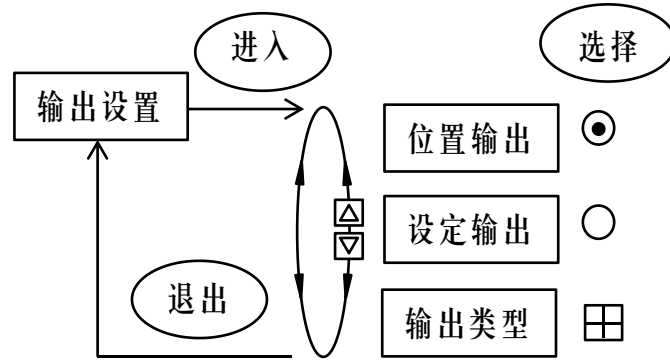
出厂设置:

信号错误选项: 错误关闭

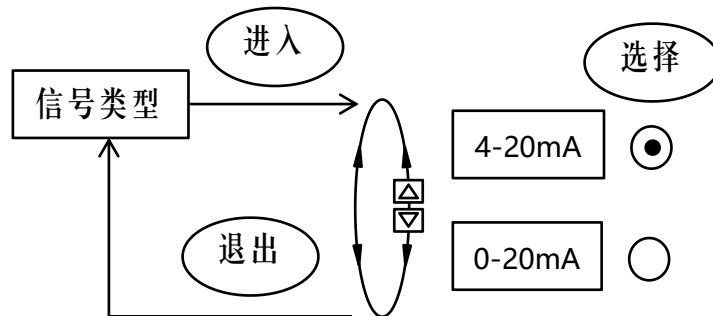
信号错误, 安全位置选项: 关闭

信号错误功能用来检测 4~20mA 输入信号的错误, 但无法检测其他类型的输入信号。信号出错条件为外部输入信号 $\leq 3.5\text{mA}$ 。如果开启了错误检测, 一旦检测到错误, 工作界面上的设定值将显示“错误”。如果没有使能安全位置, 定位器将排空执行器气缸空气。



图 29. 信号错误操作结构

选项	描述
错误关闭	信号错误检测不使能。
错误开启	信号错误检测使能。
安全位置	选择“开启”和“错误开启”选项后，当检测到错误输入信号时，安全位置功能使能。

表 7. 信号错误选项

5.3.3.9. 用户校正

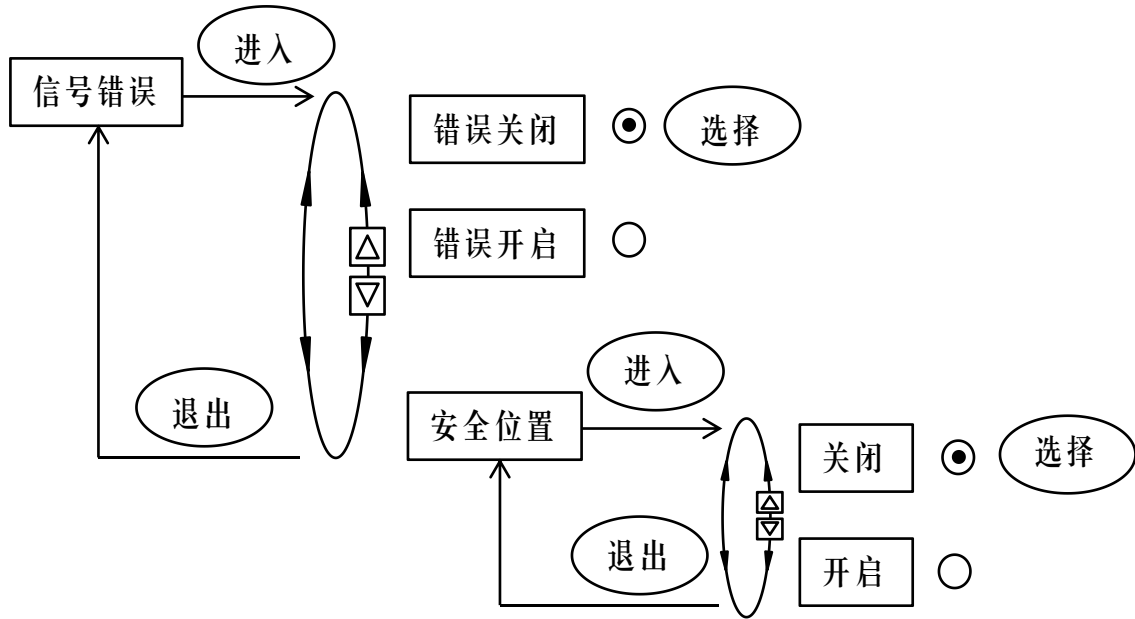
出厂设置：

位置校正最小值：自整定后的位置最小开度 AD 采样值

位置校正最大值：自整定后的位置最大开度 AD 采样值

4-20mA 设定信号校正最小值：655

4-20mA 设定信号校正最大值：3277

0-20mA 设定信号校正最小值：0

0-20mA 设定信号校正最大值：3277

此功能用于校正阀门行程和设定信号的量程值。此功能不推荐一般用户使用。

校正数值为系统 12 位 AD 采样值，取值范围为 0-4095。



图 30. 用户校正操作结构

选项	描述
位置校正	<p>阀门行程量程值的校正。</p> <p>当设置最小值时，阀门自动完全关闭；当设置最大值时，阀门自动完全打开。设置界面会显示当前的校正 AD 值和高亮显示的当前阀位 AD 值。</p>
设定校正	<p>设定信号量程值的校正。</p> <p>当设置此选项时，执行器完全排空空气，不进行其它操作。设置界面会显示当前的校正 AD 值和高亮显示的当前输入信号 AD 值。</p>
恢复缺省	位置校正和设定校正的参数恢复至出厂设置值。

表 8. 用户校正选项

当系统运行位置校正或设定校正操作时，观察高亮显示的变化值是否趋于稳定，可依照跳变的数字量范围长时间在 5 个以内认为稳定。判定稳定之后，按“确定”按键，系统会记录当前变化值作为校正的最小或最大值。记录后的校正值可能会与记录前的变化值不同。

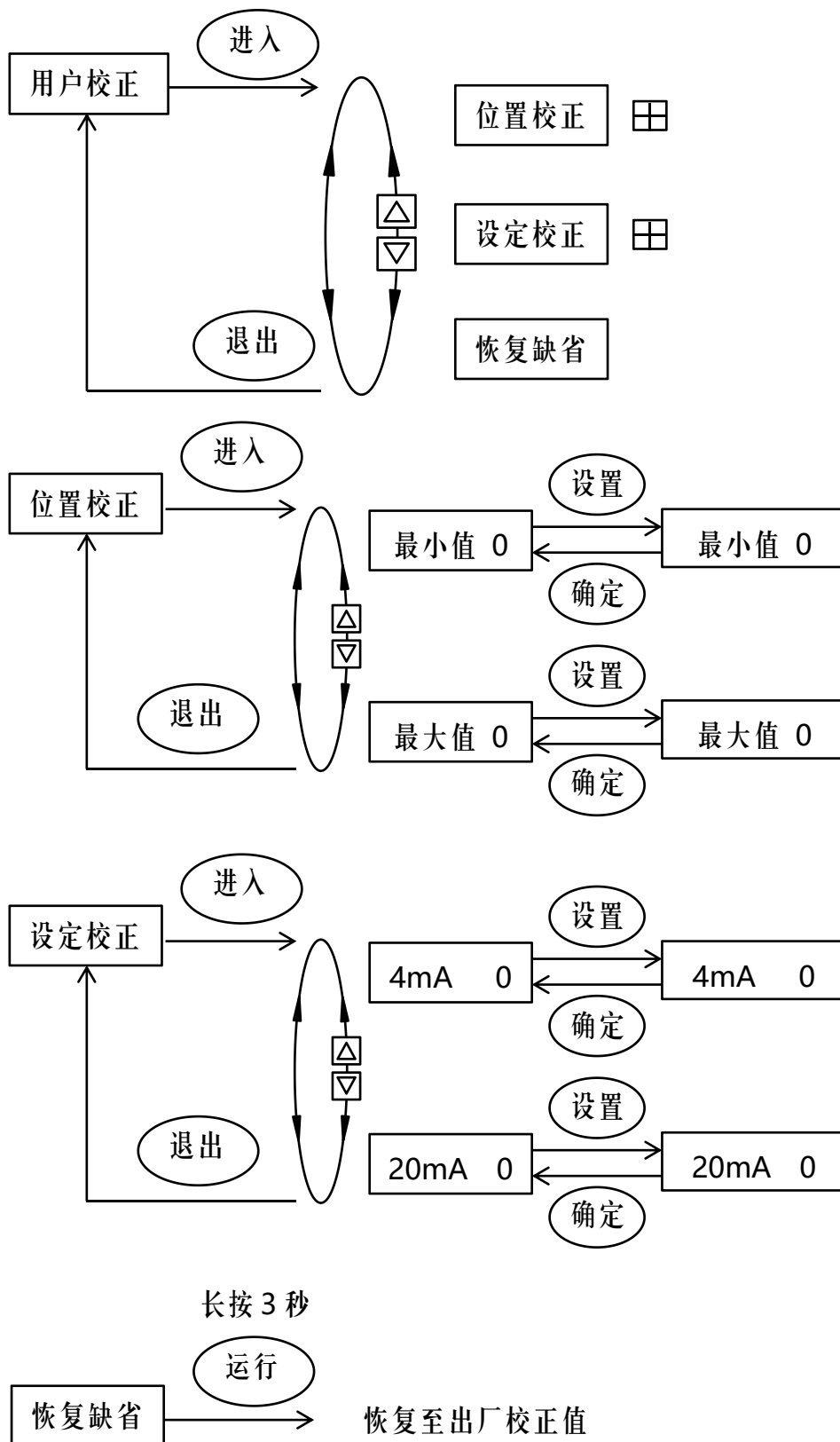
注意！

记录校正前记下当前变化值。将被记录的变化值可能与记录后的值不同。如果它们之间的数字量偏差小于 3，则记录的值可用。否则请重新运行相关值的校正

5.3.3.10. 手动速度

出厂设置：

速度等级：2

此功能用于设置手动模式下调节阀门开闭的速度。调节的速度等级有 1-5 级，

1 为最小调节速度，5 为最大调节速度。



图 31. 手动速度操作结构

5.3.3.11. 密码保护

出厂设置：

密码：0000

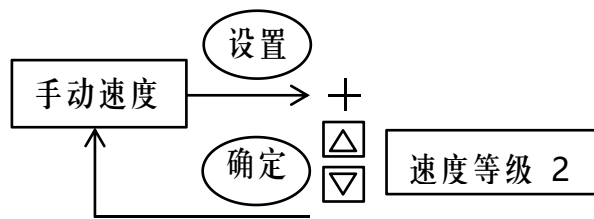
保护选项：无

此功能用于防止系统一些功能的运行和访问。如果使能了密码保护功能，当打开被保护的菜单或运行被保护的功能前需要输入密码。



图 32. 密码保护操作结构

选项	描述
主菜单	进入主菜单的密码保护。
手自切换	自动模式和手动模式切换的密码保护。
附加功能	进入附加功能菜单的密码保护。
自整定	运行自整定功能的密码保护。
密码修改	对保护选项和进入密码保护菜单的密码的修改。

表 9. 密码保护选项

5.3.3.12. 出厂设置

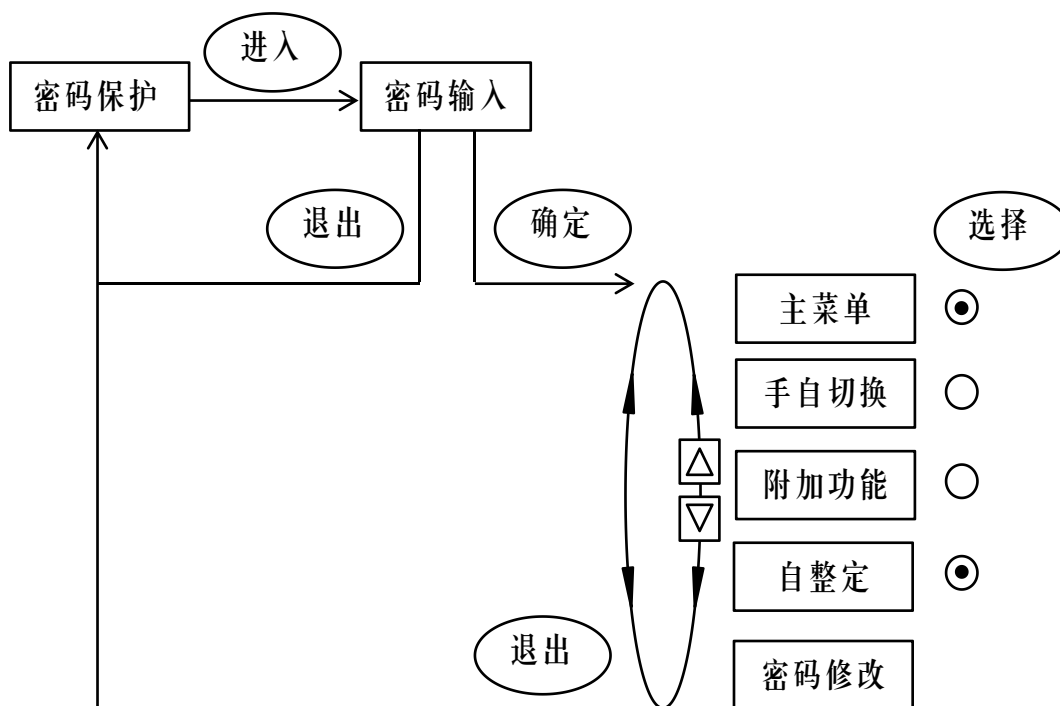
所有设置参数（不包括自整定和用户校正参数）恢复至出厂默认设置。需要恢复时，进入附加功能菜单，选择出厂设置选项，按住“运行”键三秒即可。



图 33. 出厂设置操作结构

5.3.4. 界面语言

此选项用于选择界面语言。

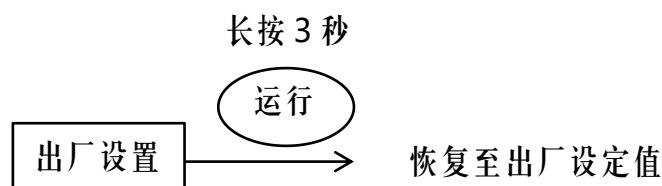

图 34. 界面语言操作结构

6. 问题排除

1. 定位器上电后显示屏不亮

确保直流 24V 电源供电正常，供电线缆连接正确。

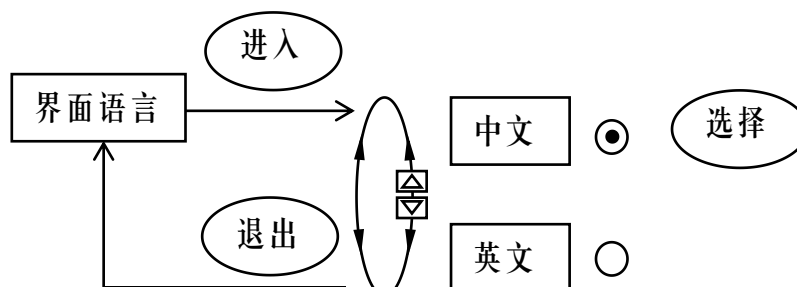
2. 定位器长时间无法定位或者阀门无法全开或全关

确保进气气压达到要求；确保行程限制或死区设置没有过小；确保执行机构和定位器的气动端口没有漏气现象。

7. 注意事项

1. 您采购的定位器的电源电压为 24V DC $\pm 10\%$ ，请用万用表确认后再接入定位器电气端子。连接电气端子到定位器前请确认电源是否切断。接入过大电压造成的产品损坏不在保修内。

2. 气源使用规范

1> 产品的气源供气压力最大不能超过 0.7MPa。

2> 产品的气源连接口前方必须安装过滤精度为 5um 的过滤减压器，防止水分，油污等异物渗入。对于压缩空气中油污比较多的情况，建议增加安装过滤精度 0.3um 以下的油雾分离器。推荐用户使用 SMC 过滤器和油雾分离器，型号为 AC20D-01CG-A。对于未加装以上要求的过滤减压器或油雾分离器导致过量油污进入定位器内部造成元器件损坏的不在保修范围内。

3. 防水电气接头使用规范

1> 电气接口有防呆设计，请按照 X1、X2 标识对应插入到防水针插公头。如果没有对应且强行插入会造成插针弯曲损坏。

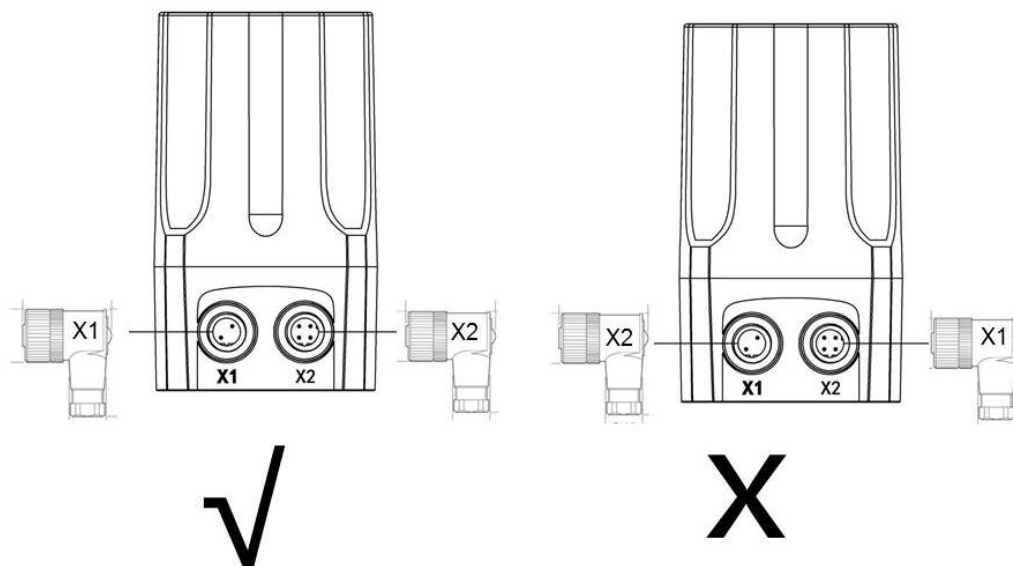

2> 防水电气接头兼容的线缆外径为 PG7(4mm-6mm)。请使用有外部绝缘保护皮的国标多芯线，否则电气接头不能保证 IP66 的防水等级。

正确和错误的接线方式如下图所示：



- 3> 电气接口如长时间不使用, 请将防水针插母头连接到定位器防水针插公头, 并且用提供的硅胶堵头将引线口堵死。防止水蒸气或者腐蚀性气体腐蚀插针或侵入损坏定位器。

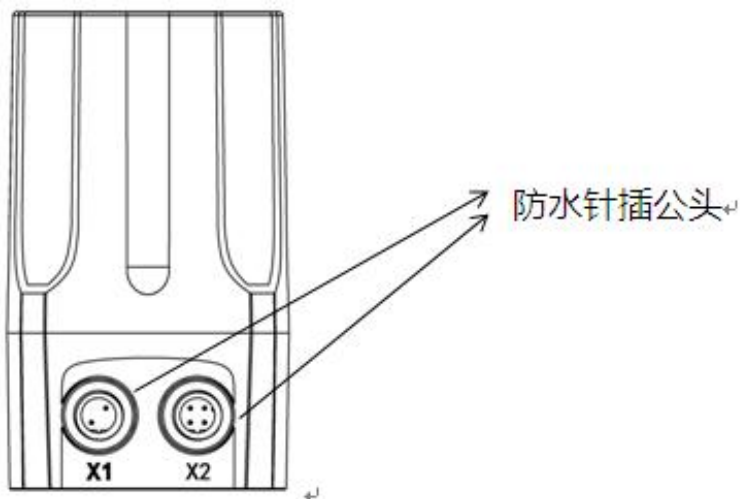

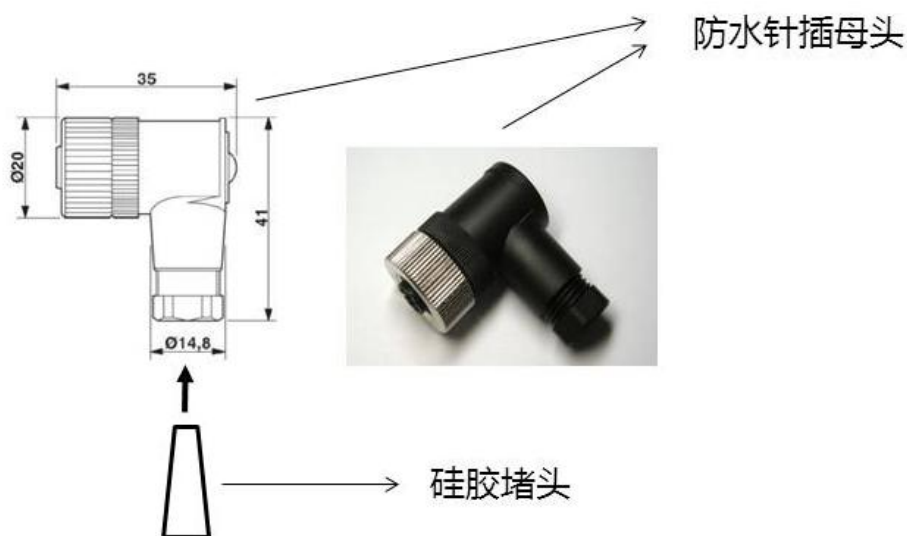

未严格按上述防水电气接头使用规范使用防水接头造成的定位器损坏不在保修范围内。

4. 用户私自拆除定位器上的气动接头或气动接头处的滤网而造成的定位器损坏不在保修范围内。

8. 保修条款

1. 发现产品有质量问题，经我公司人员确认后，客户享有在质保期内免费更换或维修的售后服务。服务响应时间为 24 小时（非工作日除外）。
2. 产品的质保期以本公司最新质保政策为准，不低于售出后 12 个月。
3. 如下情况的返修品，不属质保范围：
 - (1) 超过质保期的产品。

- (2) 未经我公司授权和允许，私自拆装过的产品。
- (3) 未按产品使用说明书操作或其他人为因素造成的产品损坏, 包括但不限于:
 - 1> 产品表面有碰撞伤痕。
 - 2> 接线或供电错误造成元器件损坏。
 - 3> 零部件或配件丢失。
 - 4> 未加装过滤减压器或油雾分离器导致油污进入产品内部造成元器件损坏。
 - 5> 未按使用规范使用防水电气接头导致产品损坏。
- (4) 不可抗拒因素（自然灾害）造成产品故障或损毁。
- 4. 不属于产品质保范围的维修，我公司将视实际情况提供免费或收费维修服务。
- 5. 本条款自双方签定供货合同时生效。

9. 选型及订货数据

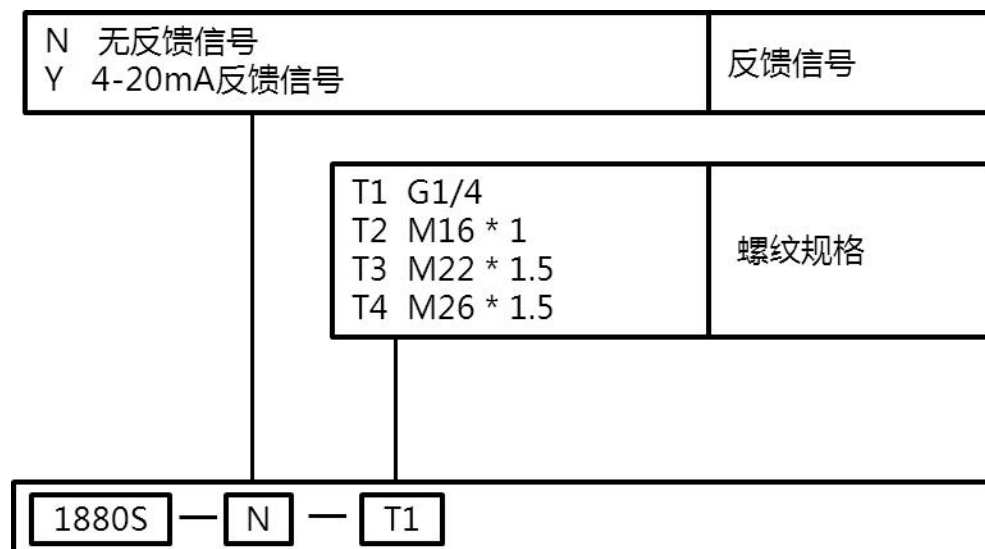

备注：

该产品只适用于单作用直行程执行器。断电状态为复位。建议匹配气室内径 40-100 mm 的执行器。

Contents

1. Overview	43
1.1. Product structure	43
1.2. Product description and application	44
2. Installation	45
2.1. Mechanical dimensions	45
2.2. Actuator combination	46
2.3. Interface angle adjustment	49
3. Connection description	50
4. Technical data	52
4.1. Working data	52
4.2. Electrical data	52
4.3. Mechanical data	52
4.4. Pneumatic data	52
5. Operation	53
5.1. Interface description	53
5.2. Operating mode and operating interface	54
5.3. Main menu	56
5.3.1. INPUT	56
5.3.2. AUTO TUNE	57
5.3.3. ADD FUNC	59
5.3.3.1. CHARACT	60
5.3.3.2. CUTOFF	63
5.3.3.3. DIR CMD	65
5.3.3.4. LIM STROKE	66
5.3.3.5. DEAD BAND	68

Intelligent Valve Positioner 1880S Series User's Manual

5.3.3.6. SAFEPOS	69
5.3.3.7. OUTPUT(optional).....	69
5.3.3.8. SIG ERROR.....	70
5.3.3.9. CAL USER.....	71
5.3.3.10. MANU RATE.....	74
5.3.3.11. CODE.....	74
5.3.3.12. SET FACT.....	76
5.3.4. LANGUAGE.....	76
6. Trouble shooting.....	77
7. Attention.....	77
8. Warranty terms.....	80
9. Selection and ordering data.....	81

1. Overview

1.1. Product structure

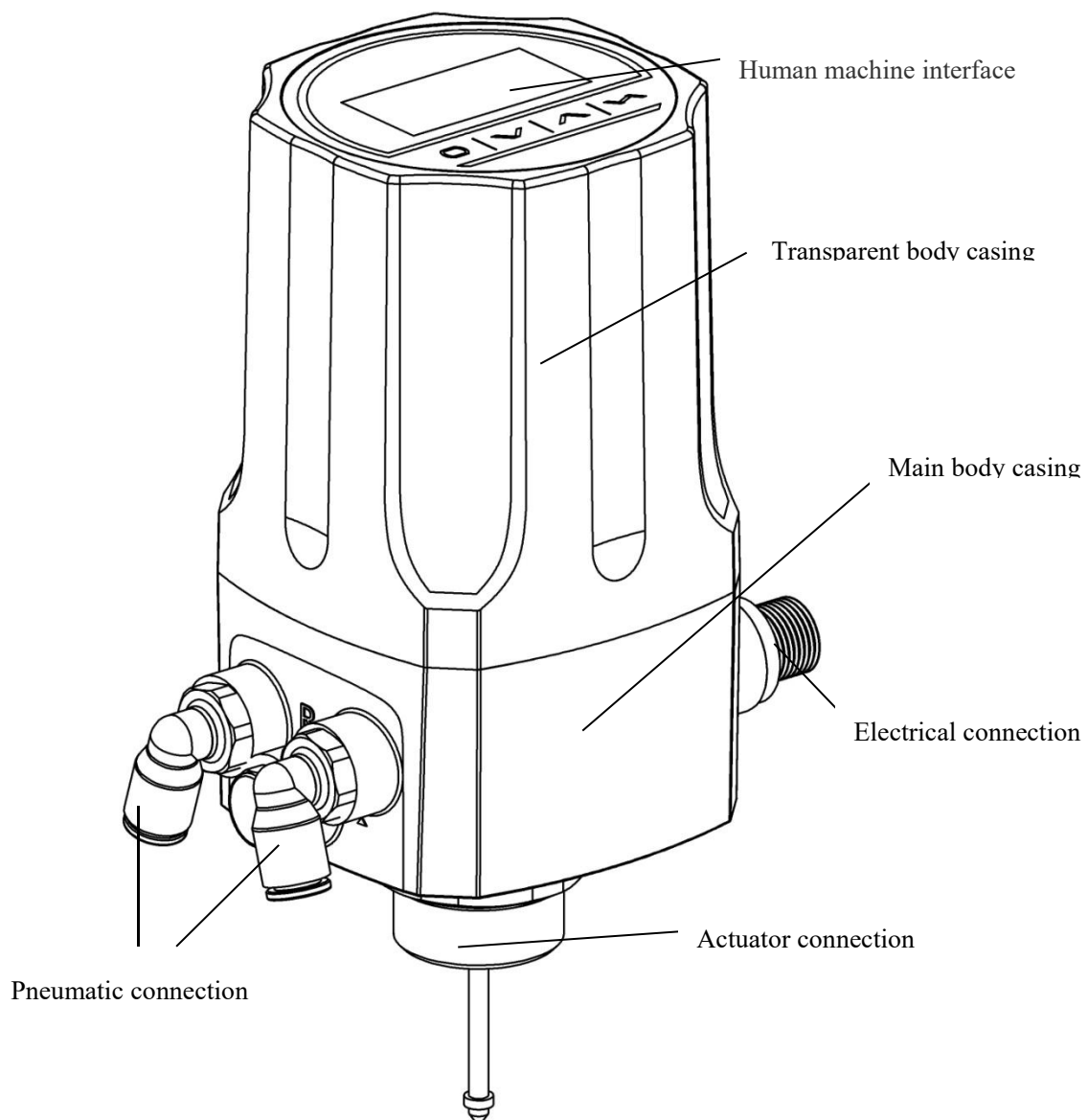

Figure 1. Positioner structure

1.2. Product description and application

1880S series intelligent valve positioner is a valve stroke controller based on microprocessor. The valve stroke can be set by external input signal. The positioner can adjust valve stroke quickly and accurately by using automatic control algorithm and PWM control technology, accordingly control the flow of fluid line.

The positioner can combine with different pneumatically actuated valves for using. As shown in Figure 2.



with diaphragm valve



with angle seat valve

Figure 2. Combinations of positioner and pneumatically actuated valves

The product can be used in sealed space and controlled automatically and remotely. It has a variety of auxiliary functions such as transfer characteristic, safety position, cut off, etc. It is easy to install, operate, maintain and has low failure rate.

2. Installation

2.1. Mechanical dimensions

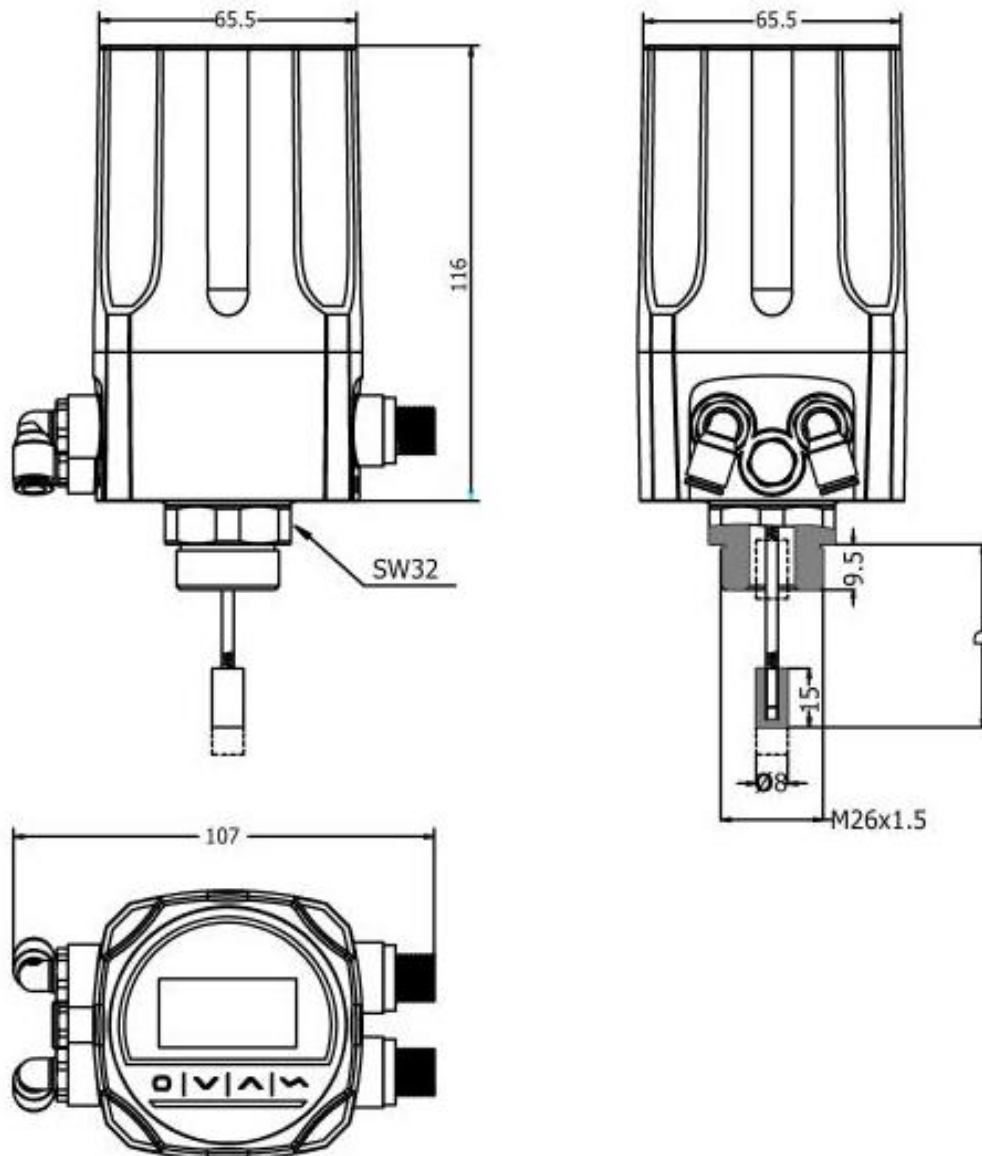

Figure 3. Mechanical dimensions

2.2. Actuator combination

1. Make sure that the stroke range and the screw thread size of the actuator which needs to combine meet the requirements.
2. Separately measure the C1 value when the valve is fully closed and C2 value when the valve is fully open by **the depth ruler**. The values are the distance between the stem top and the datum clamp face of the actuator. As shown in Figure 4.

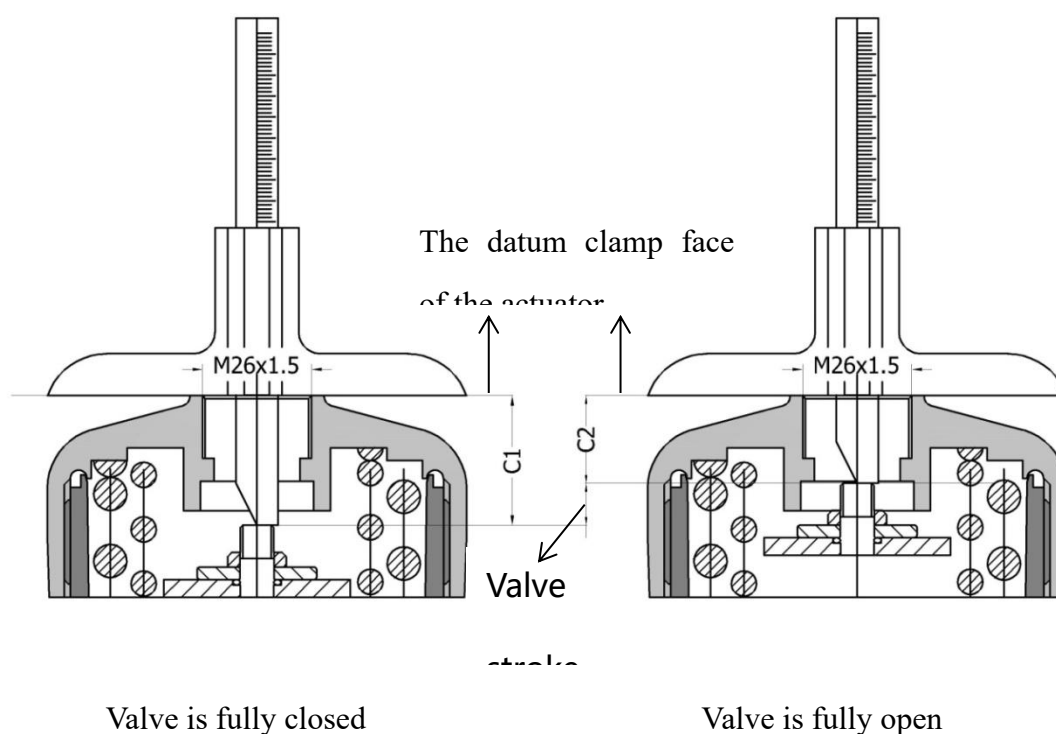

Figure 4. Actuator measurement

3. Adjust the adjusting nut of the displacement sensor. Then measure the D value (as shown in Figure 5) by **the depth ruler** in the state of the displacement sensor being completely loosened. Calculate the compression value $L1 = D - C1$, $L2 = D - C2$. It is recommended that the compression value L1 and L2 are both in the reference range which is showed in Table 1. If L1 value or L2 value is unable to meet the reference range, adjust the D value according to the actual situation.

NOTE!

The adjusted D value must ensure that $L1 > 0$, $L2 <$ the maximum compression value of the displacement sensor. Otherwise, the positioner cannot match the actuator.

Maximum valve stroke	D range	L1, L2 reference range
5~25 mm	45~51 mm	3~28 mm

Table 1. The reference range of the compression value

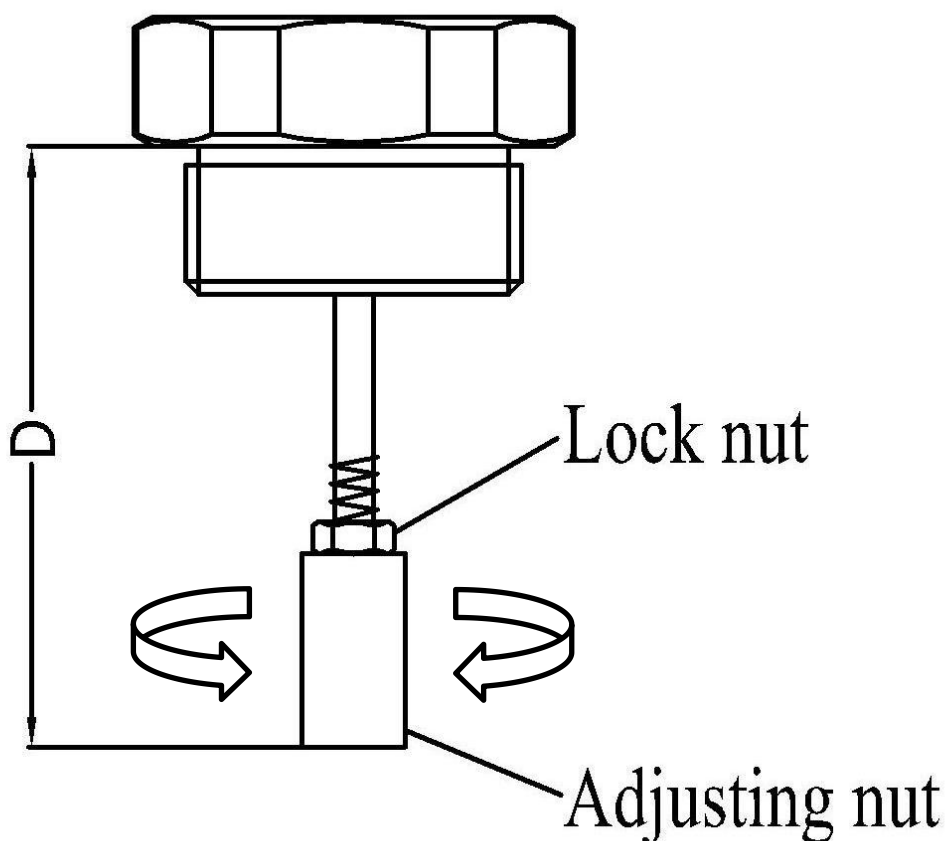

Figure 5. Travel sensor adjustment and measurement

4. Raise the internal valve stem of the actuator to the highest position. Make the actuator connection of the positioner entering into the thread connection of the actuator by **NO.32 wrench**. As shown in Figure 6.

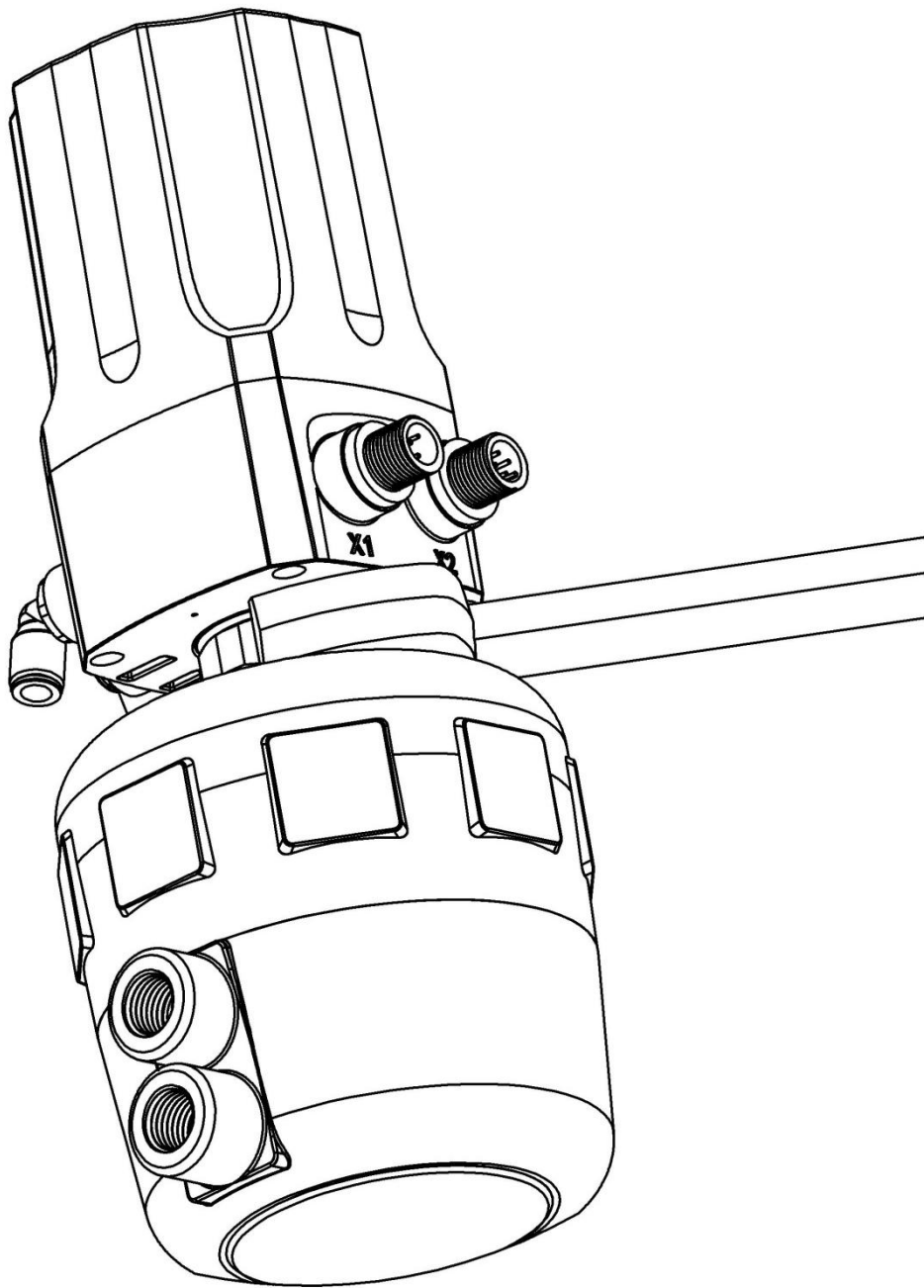

Figure 6. Actuator Combination

2.3. Interface angle adjustment

The angle can be adjusted between the positioner and the valve. If need to adjust the interface angle, rotate the main body casing clockwise or counter-clockwise in 180° range.

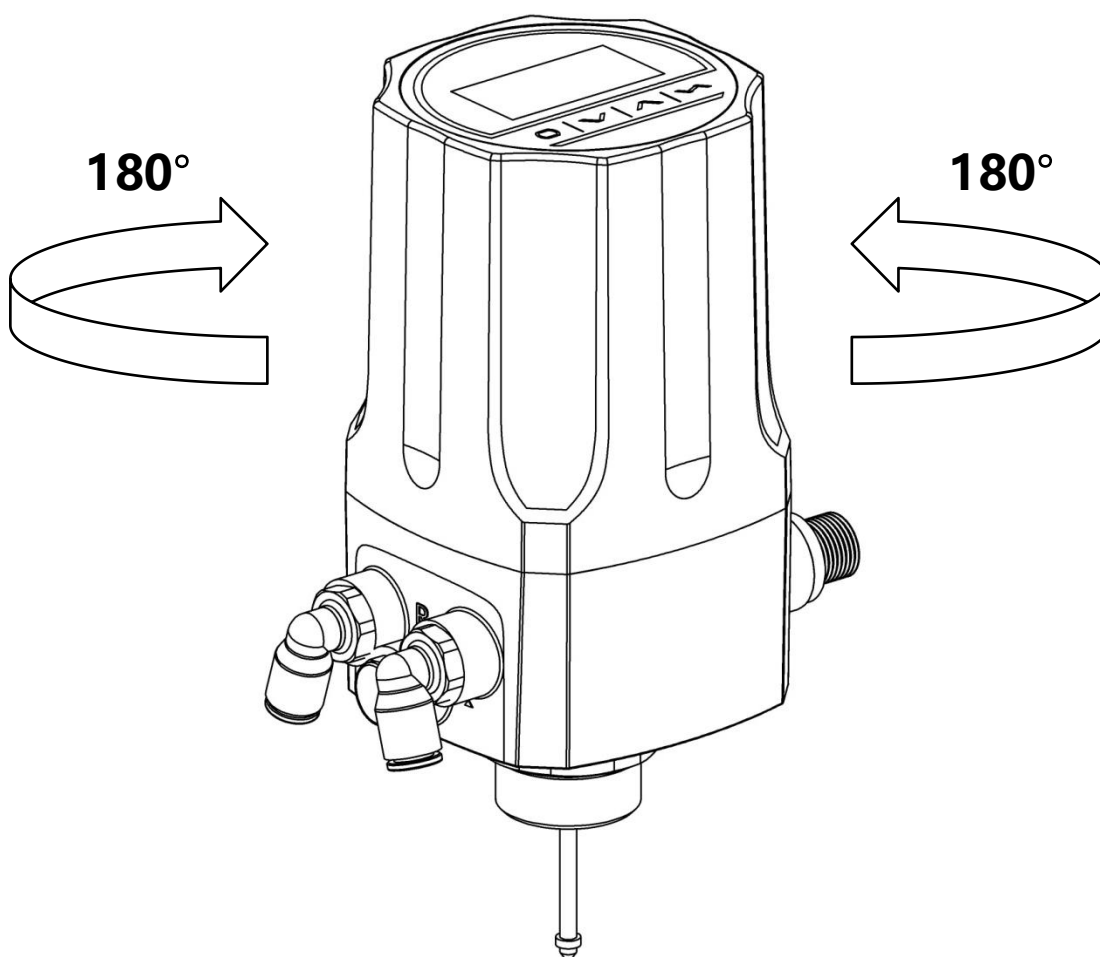

Figure 7. Graph operation

3. Connection description

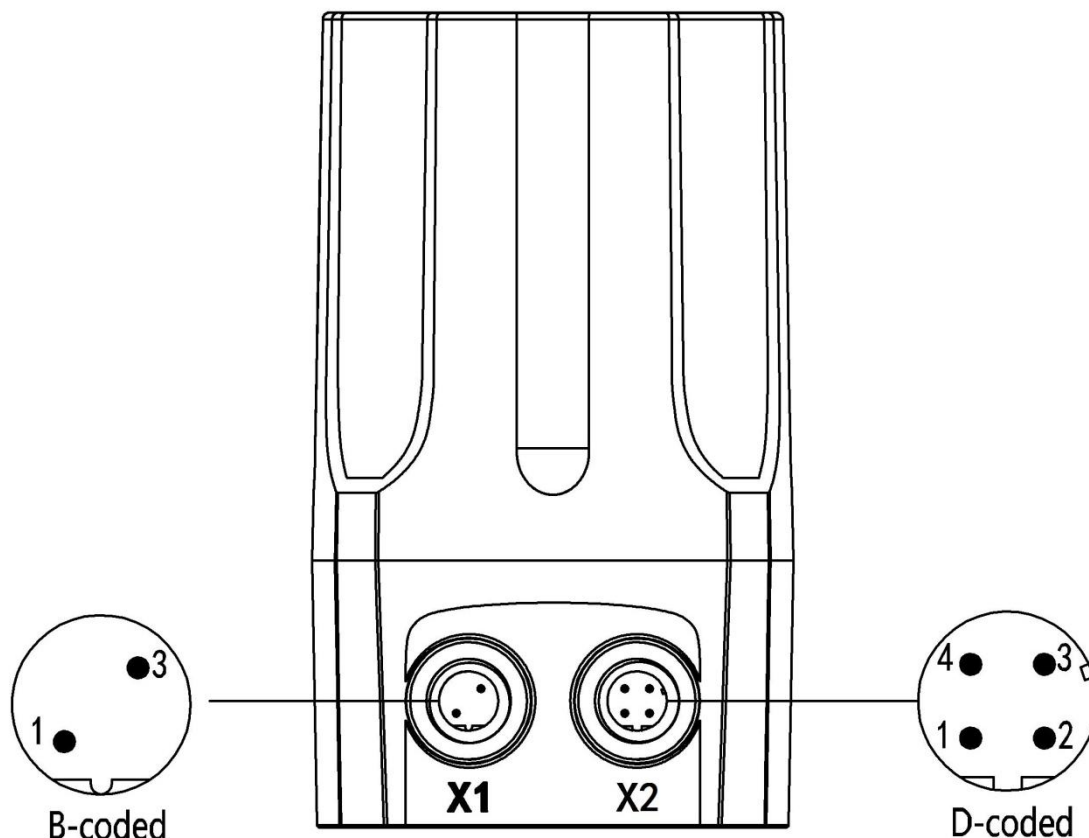

Figure 8. Connection

Connection	Pin	Description	Signal Type
X1	1	Analogue signal output +	0/4 – 20 mA
	3	Analogue signal output GND	GND

Table 2. Electrical connection description – X1(optional)

Connection	Pin	Description	Signal Type
X2	1	Power supply +	+24 V
	2	Power supply GND	GND
	3	Set signal input +	0/4 – 20 mA
	4	Set signal input GND	GND

Table 3. Electrical connection description – X2

NOTE!

Error connection of the electrical pin may cause the positioner damage.

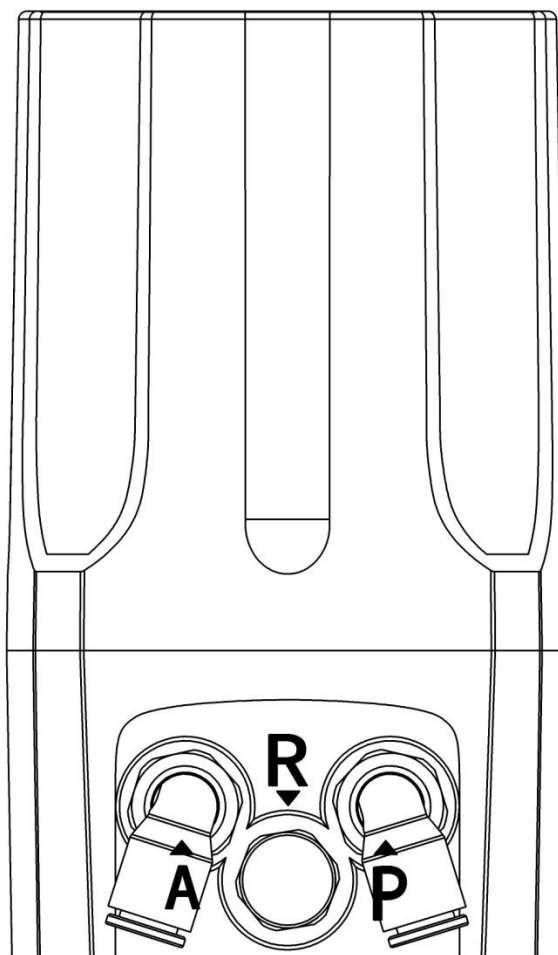

Connection	Description
P	Air supply enter (built-in filter, filter size 20 μm)
R	Air exhaust
A	Pilot air outlet

Table 4. Pneumatic connection description

NOTE!

The air source pressure bigger than 7 bar may cause positioner damage.

4. Technical data

4.1. Working data

Ambient temperature: 0~60 °C

Protection class: IP67

Vibration resistance parameter: 100Hz

4.2. Electrical data

Connections: cable gland

Supply voltage:

24 V DC \pm 10 %, \geq 1A. Recommend switching-mode power supply.

Power input: <5W

Input resistance for set-point signal: 120 Ω

Analogue output signal: maximum load 560 Ω

4.3. Mechanical data

Cover material: Polycarbonate (PC)

Sealing material: Silicone rubber (SI)

Main body material: Polyamide Resin (PA6-GF30)

Control stroke range: 5-25 mm

4.4. Pneumatic data

Air pressure range: 3~7 bar, specific values depending on the actuator

Connections: Plug-in hose connector G1/4

Air quality:

ISO 8573-1

Solid particle size and density Class 3

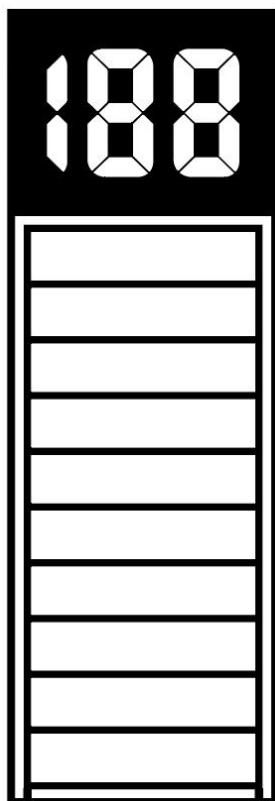



Figure 10. Secondary display

5.2. Operating mode and operating interface

The positioner has two operating mode: automatic mode (AUTO) and manual mode (MANU).

The positioner default operates in the automatic mode when powering up. At this time, the interface is locked. To unlock the interface, it needs to press both two  keys for about 3 seconds.

In the automatic mode, the positioner accepts the input signal for set-point value and adjusts the valve stroke automatically.

In the manual mode, user must press the “+/-” key to adjust the valve stroke manually. The set-point value is the current valve position after adjusting the valve stroke manually or the current valve position after switching from the automatic mode to the manual mode. It is displayed on the manual mode interface.

The operating mode can be switched by AUTO key and MANU key if BINARY IN function is not enabled for switching the operating mode. If enabling the BINARY IN

function for switching, switching by function keys is not effective.

User can switch the operating interface by the function keys. The operating interfaces are described in Table 5. The interface will be locked if no keys are pressed for a long time. To unlock the interface, it needs to press both two  keys for about 3 seconds. Under the locked interface, when the keys are not pressed for a long time, the LCD will display screensaver interface. Press any key to exit the screensaver interface.

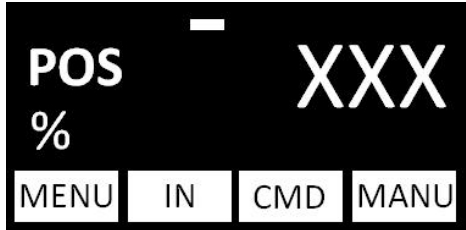
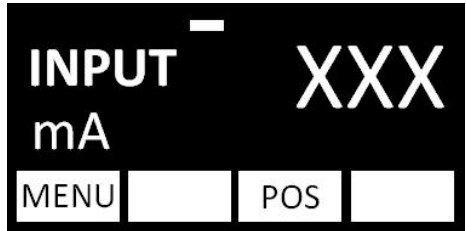
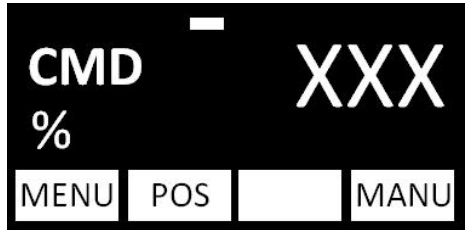
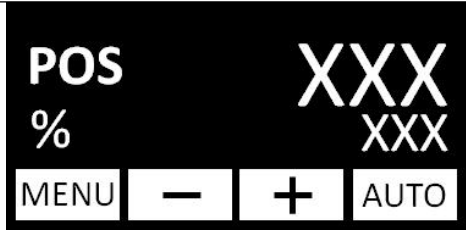
Display	Description
	Current position in the automatic mode. Press “POS” key or “AUTO” key to display.
	The value of input signal in the automatic mode. Press “INPUT” key to display.
	The set-point value in the automatic mode. Press “CMD” key to display.
	Current position value (big font) and position set-point value (small font) in the manual mode. Press “MANU” key to display.

	<p>Screensaver interface. It displays the valve position value. The cursor is displayed in automatic mode.</p>
---	--

Table 5. Operating interface

5.3. Main menu

User can operate specific function or set specific parameters under the main menu. If the menu is not operated for a long time, the system will automatically exit from the menu interface to the automatic mode locked interface.

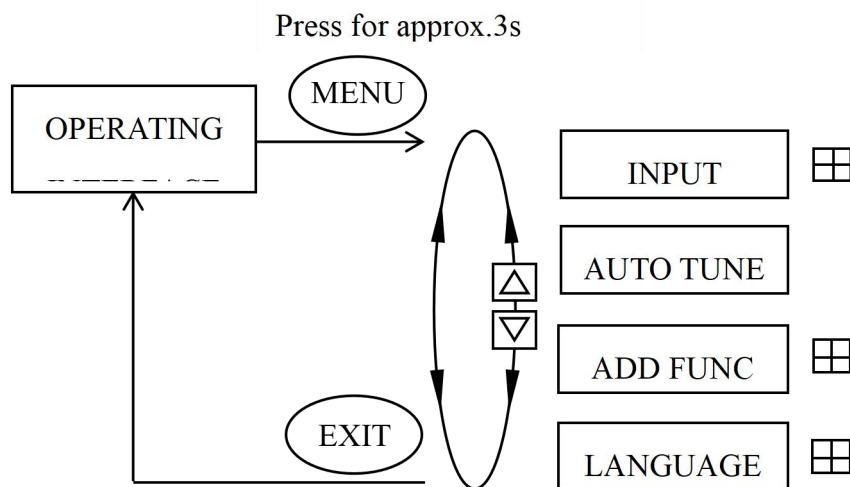

Figure 11. Operating structure main menu

5.3.1. INPUT

The option is used to select the type of the input signal for set-point value. The signal type is 4-20 mA after factory settings.

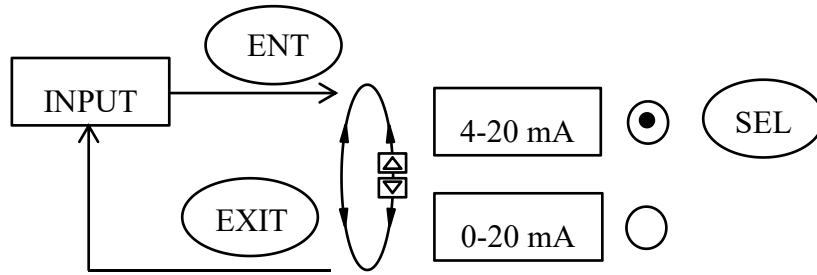

Figure 12. Operating structure INPUT

5.3.2. AUTO TUNE

The function can test the related control parameters including the direction between the aeration state of the actuator and the actual position, the total valve scale, PWM parameters. The whole process will continue for about 2-3 minutes if running normally.

System will check whether the whole valve stroke range is in the effective range of the displacement sensor during the automatic adjustment process. When the whole valve stroke range is out of the effective range of the displacement sensor, if the minimum value of the whole valve stroke range is smaller than the minimum value of the effective range of the displacement sensor, OLED displays “POS MIN ERROR”, if the maximum value of the whole valve stroke range is larger than the maximum value of the effective range of the displacement sensor, OLED displays “POS MAX ERROR”. If OLED displays the error information above, it is need to re-match the positioner and the actuator, refer to Chapter 2 for details.

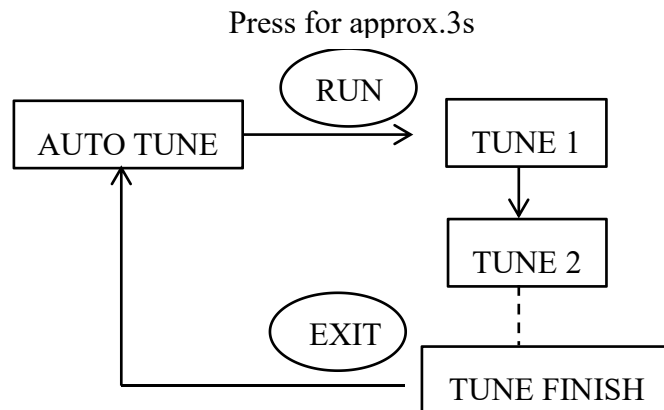

Figure 13. Operating structure AUTO TUNE

NOTE!

- Although the positioner has ran the automatic adjustment function in the factory. In order to get the control parameters of the actual work environment, the positioner must run the function again in the actual work environment.
- Make sure that the air supply pressure is in the working range of the actuator and has no big wave. Otherwise the automatic adjustment may fail or the test

5.3.3. ADD FUNC

The option includes auxiliary functions.

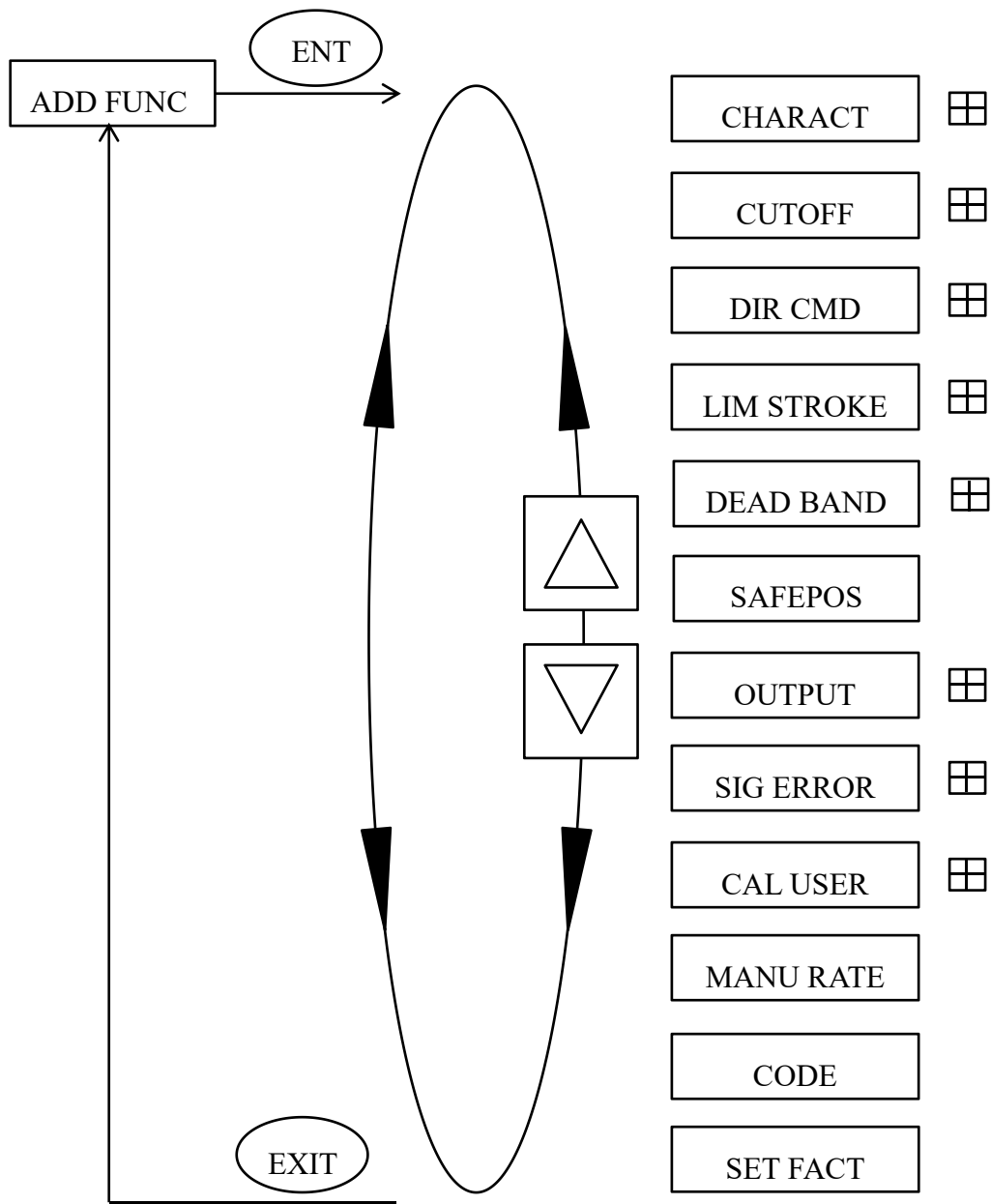

Figure 14. operating structure ADD FUNC

5.3.3.1. CHARACT

Factory setting:

CHARACT option: LINEAR

EQ PERC option: 1:25

FREE value: 0%, 5%, 10%.....95%, 100%

The CHARACT function is to determine the relationship between position set-point value and valve stroke. In the actual control system, the controlled variable is usually required to have specific control characteristic, such as linearity. User can select or set the characteristic option to meet the control requirement in the function menu.

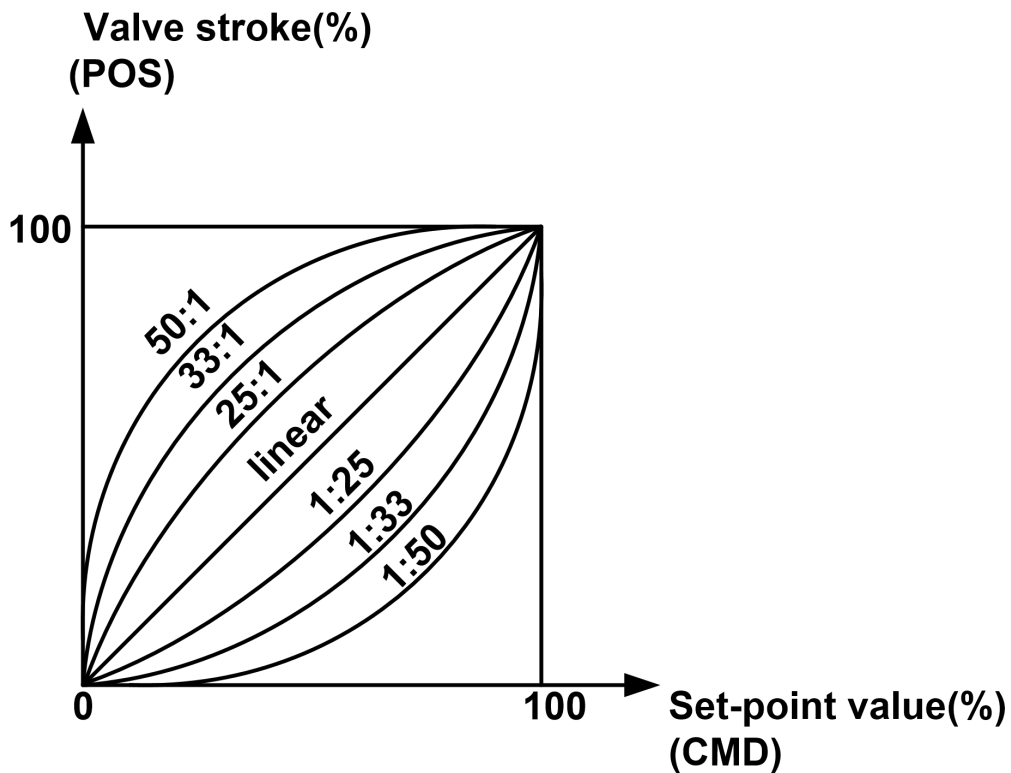

Figure 15. Graph characteristics of linear and equal percentage

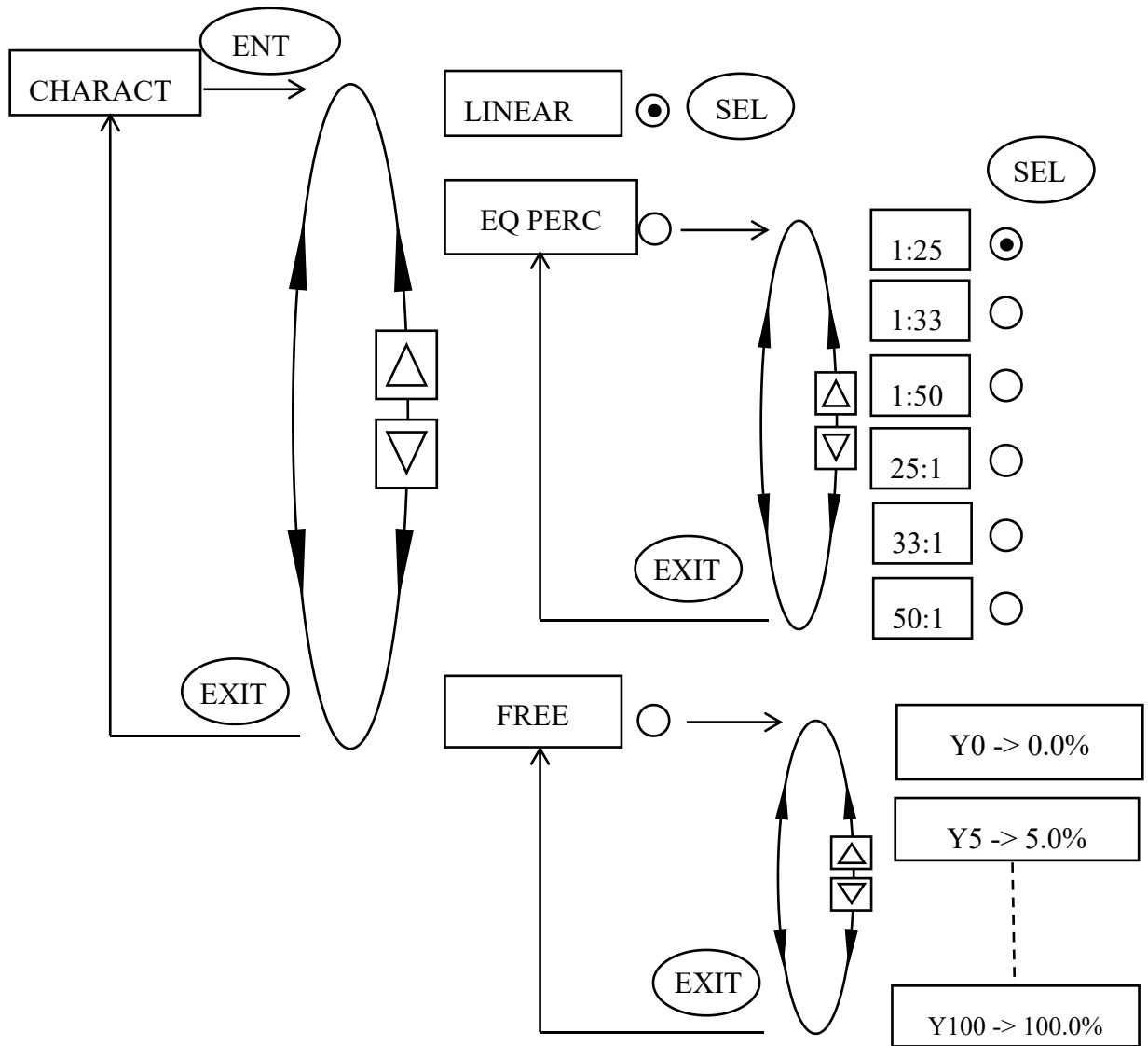

Figure 16. Operating structure CHARACT

Option	Description
LINEAR	1:1 linear transfer relationship between position set-point value and valve stroke.
EQ PERC	Equal percentage transfer relationship between position set-point value and valve stroke.
FREE	Freely programmable transfer relationship between position set-point value and valve stroke for user.

Table 6. Option CHARACT

Equal percentage characteristic

The Equal percentage characteristic includes the options of 1:25, 1:33, 1:50, 25:1(inverse), 33:1(inverse), 50:1(inverse).

Freely programmable characteristic

User can program free characteristic by operating the FREE option.

The position set-point value scale ranging from 0-100 % is divided uniformly into 21 nodes. A freely programmable valve stroke ranging from 0-100 % is assigned to each node.

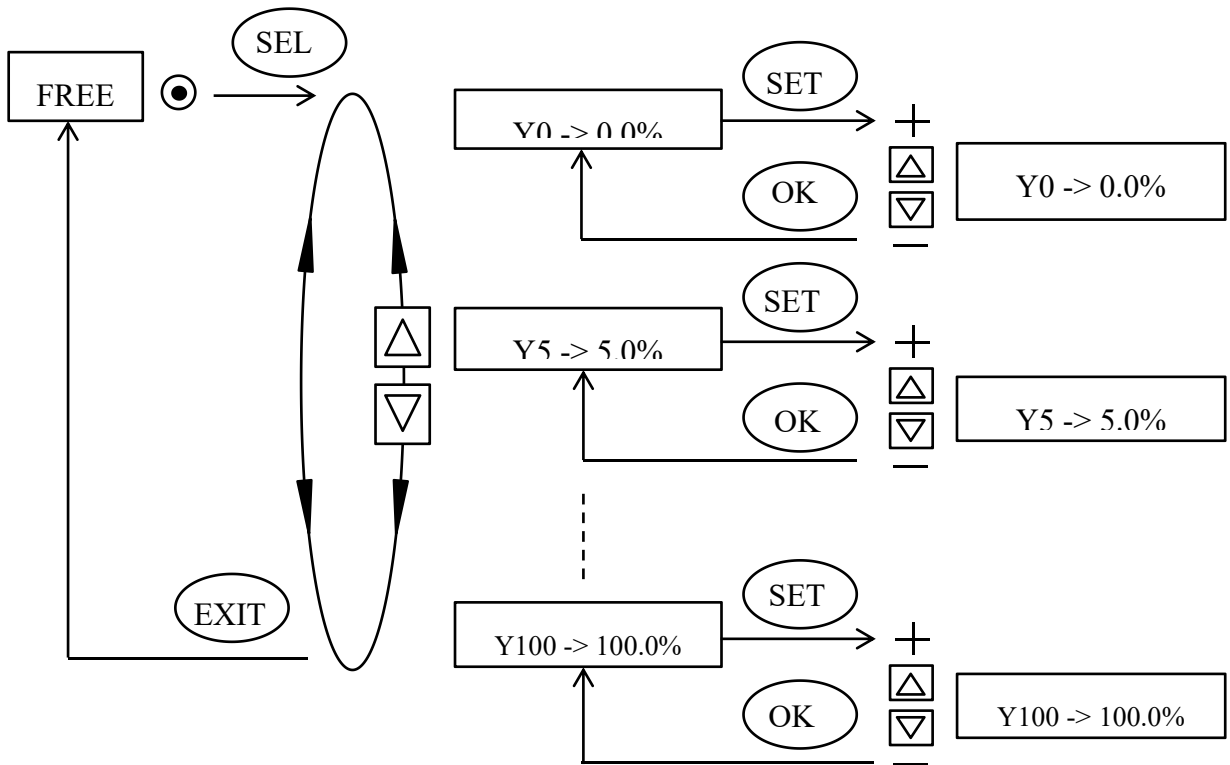

Figure 17. Operating structure CHARACT FREE

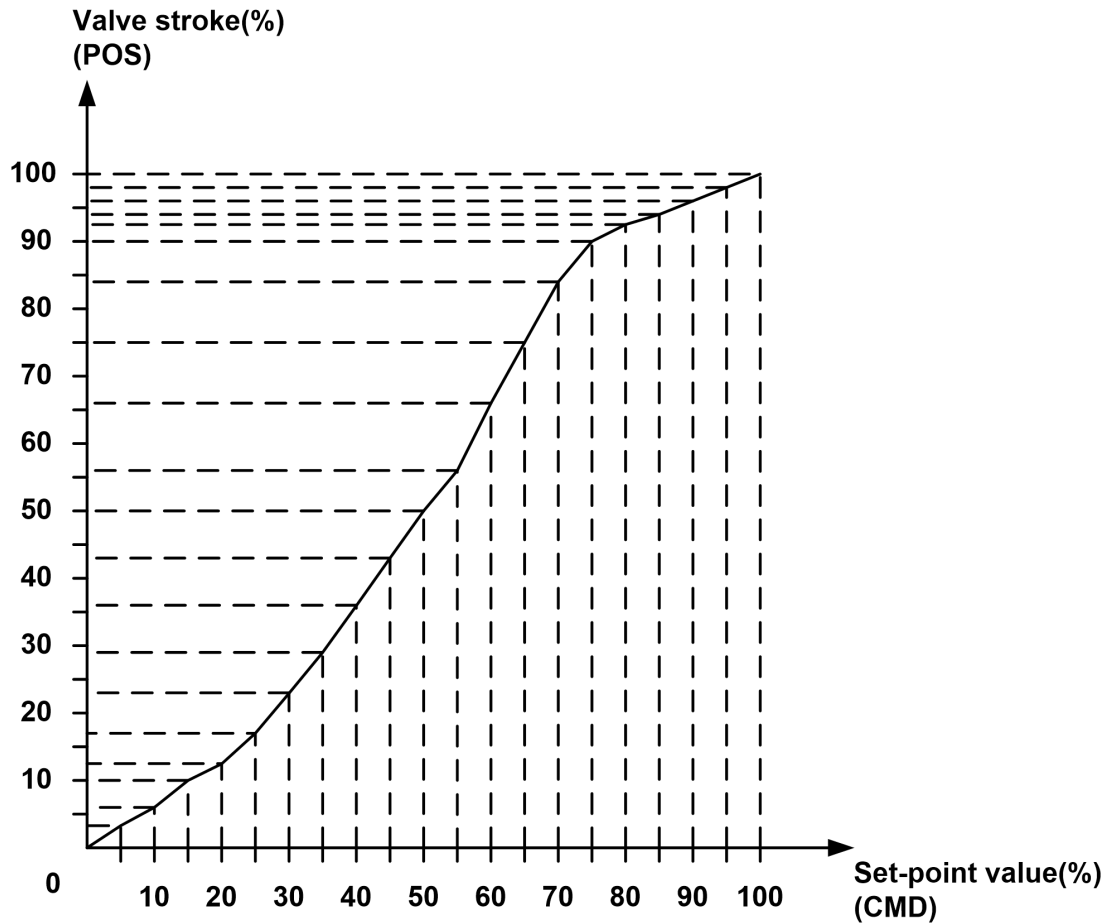

Figure 18. Graph CHARACT FREE

5.3.3.2. CUTOFF

Factory setting:

AUTO CUT MIN value: 1%, AUTO CUT MAX value: 99%

MANU CUT MIN value: 2%, MANU CUT MAX value: 98%

When the percentage of set-point value is in the enabled range of CUTOFF, the valve is fully deaerated or aerated. The valve is fully close when the percentage of set-point value is less than or equal to MIN setting parameter and is fully open when the percentage of set-point value is greater than or equal to MAX setting parameter.

The function divides into AUTO CUT function in the automatic mode and MANU CUT function in the manual mode. Parameter MIN range: 0-25%, Parameter MAX range: 75-100%. When the function is enabled, the sign “cut off ” is indicated on the

operating interface.

In the automatic mode, when the MIN data is 0%, CUTOFF for closing the valve is inactive; when the MAX data is 100%, CUTOFF for opening the valve is inactive.

When the positioner is running the function, due to the actuator internal characteristics, the valve position will have some deviations after the valve being fully closed or fully opened. As a result, the position value may be smaller than 0% when the valve is fully closed or bigger than 100% when the valve is fully opened.

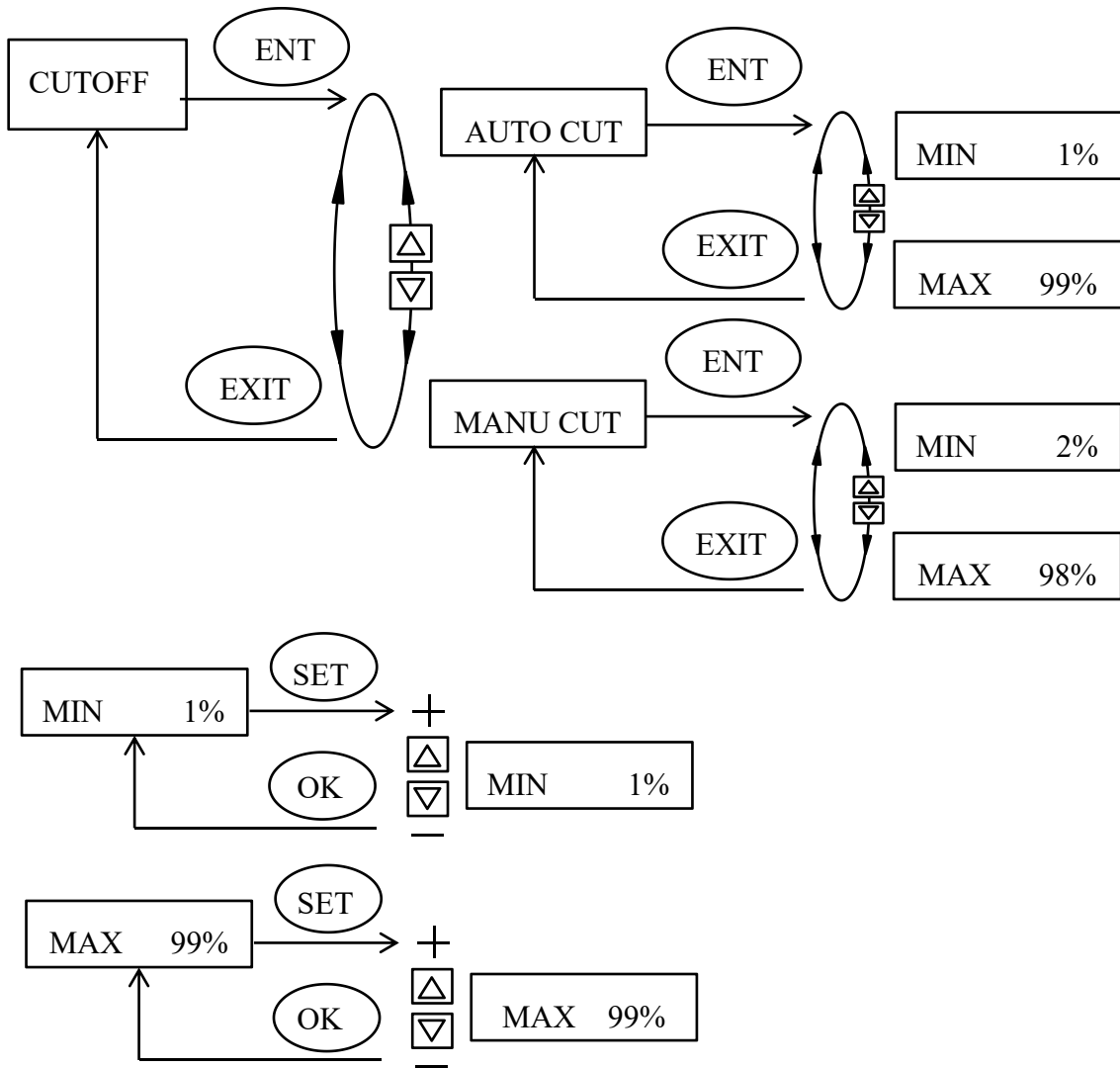

Figure 19. Operating structure CUTOFF

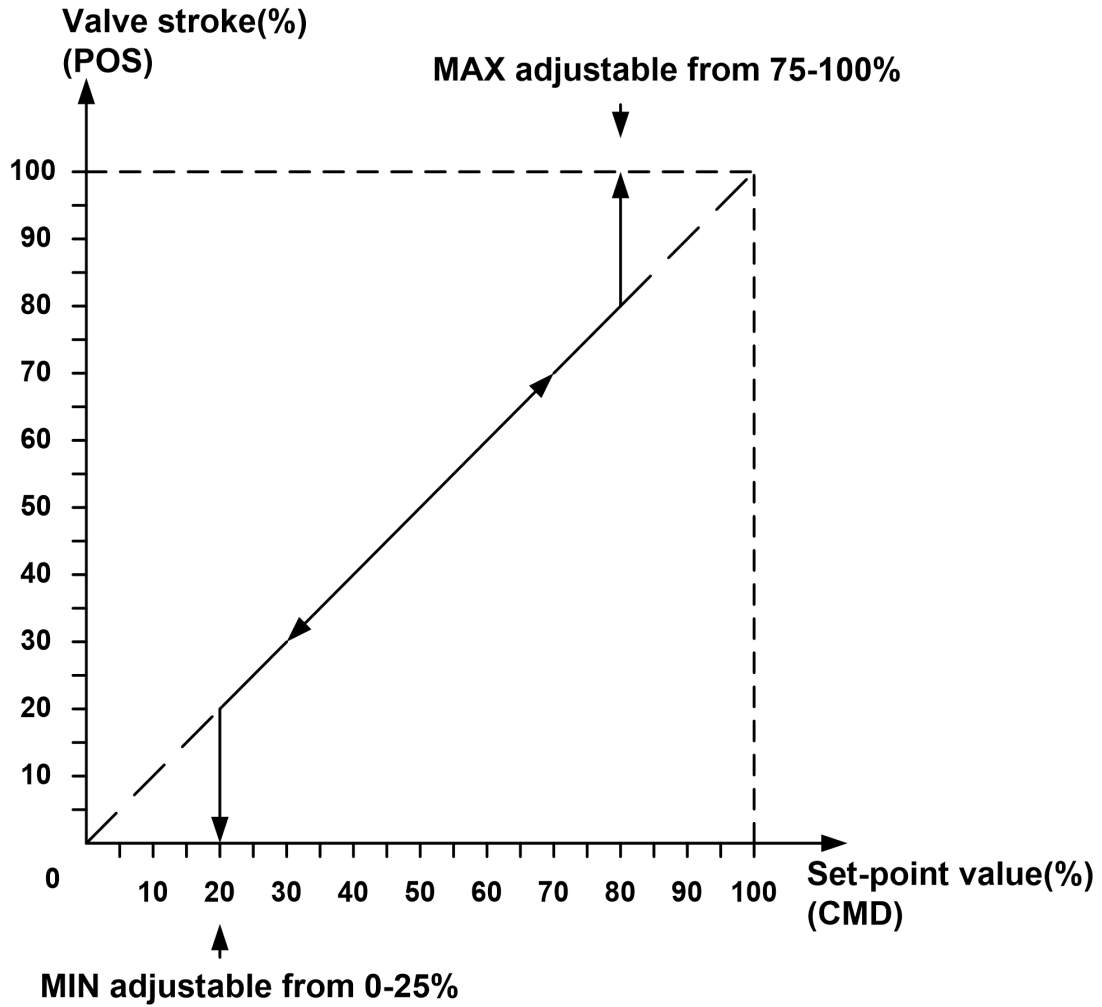

Figure 20. Graph CUTOFF

5.3.3.3. DIR CMD

Factory setting:

DIR CMD option: RISE

The function is to set the effective sense of direction between the input signal and the position set-point value (CMD).

RISE: 0/4 mA → 0%, 20 mA → 100%.

FALL: 0/4 mA → 100%, 20 mA → 0%.

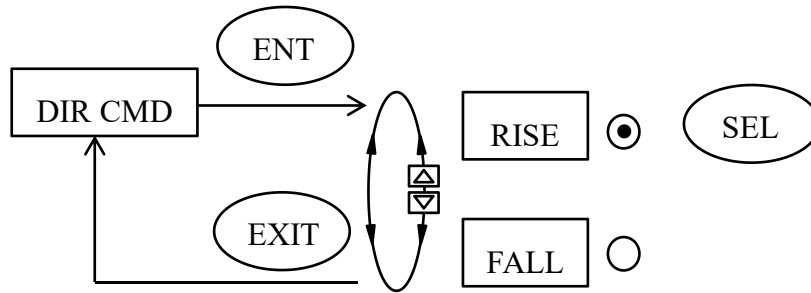

Figure 21. Operating structure DIR CMD

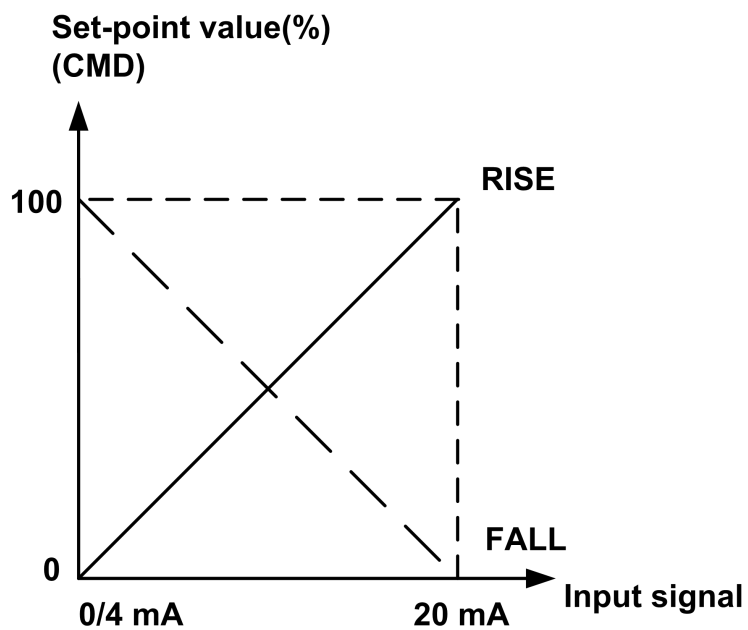

Figure 22. Graph DIR CMD

5.3.3.4. LIM STROKE

Factory setting:

LIM STROKE MIN value: 0% (unlimited)

LIM STROKE MAX value: 100% (unlimited)

The function limits the automatic adjustment range in the whole valve physical stroke. After setting the limit value, the value of valve stroke (POS) on the display may bigger than 100% or smaller than 0%.

MIN adjustment range: 0 – 50 % of the total physical stroke.

MAX adjustment range: 50 – 100 % of the total physical stroke.

The minimum gap between Min and Max is 50 % of the total physical stroke.

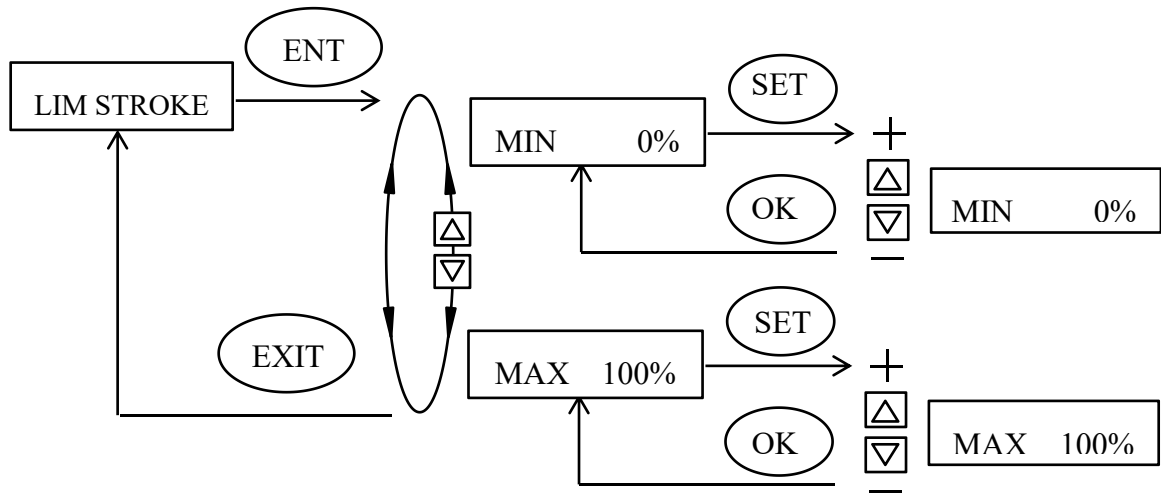

Figure 23. Operating structure LIM STROKE

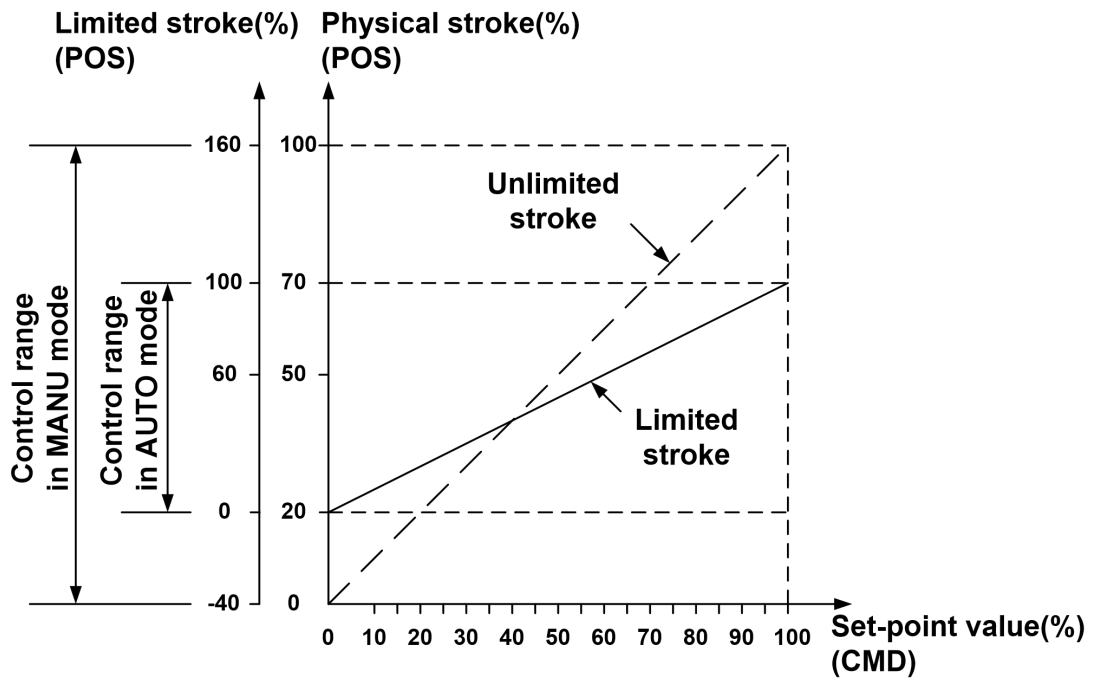

Figure 24. Graph LIM STROKE

NOTE!

Please do not set the minimum gap between Min and Max too small in application, since it may increase the difficulty of valve stroke adjustment. If to do so for necessary, please change the AUTO DB value bigger.

5.3.3.5. DEAD BAND

Factory setting:

AUTO DB value: 1%

MANU DB value: 1%

The system does not adjust the valve stroke when the gap between the stroke value and the position set-point value is not bigger than the dead band value. The dead band value is divided into automatic dead band value and manual dead band value. The automatic dead band value corresponds to limited scale of the valve stroke. The dead band range is 0.1%-10%.

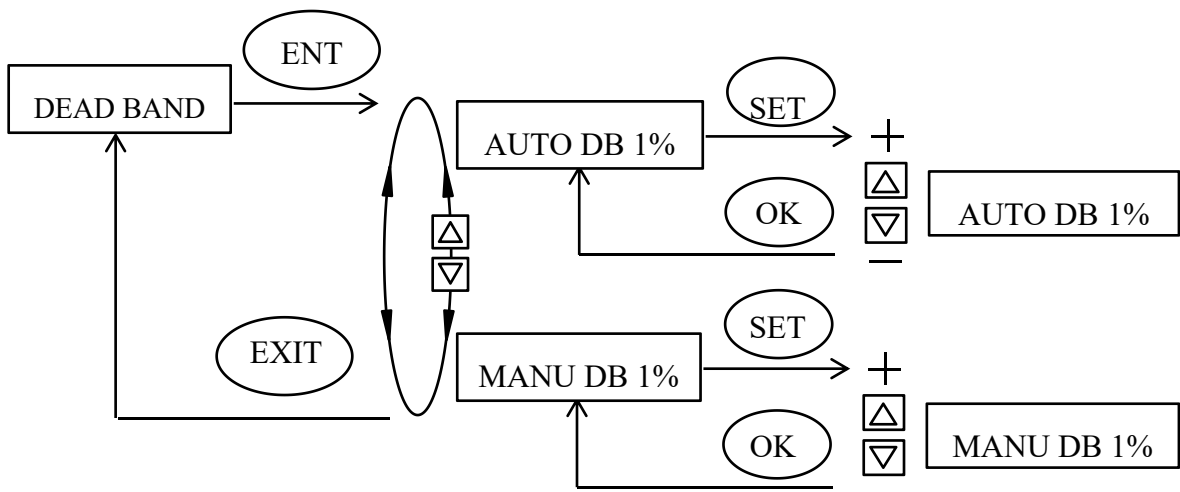

Figure 25. Operating structure DEAD BAND

NOTE!

The smaller the dead band setting, the higher the control accuracy getting.
 Please set the dead band value in reason. Because the too small value may cause the solenoid valve in the body to act frequently and lead to long adjustment time and unstable working state.

5.3.3.6. SAFEPOS

Factory setting:

SAFEPOS value: 0%

The function is used to set a safety position which the valve stroke is adjusted to for some specific conditions. The safety position is adjusted by the binary input signal or an error signal for set-point value. When the adjustment for the safety position is enabled, the sign “safe pos” is indicated on the operating interface.

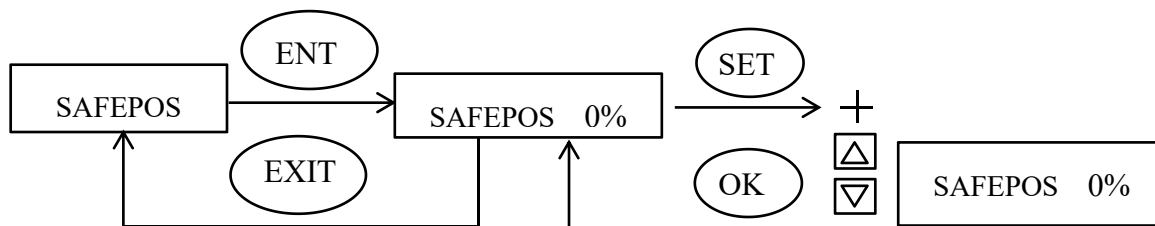

Figure 26. Operating structure SAFEPOS

5.3.3.7. OUTPUT(optional)

Factory setting:

ANALOGUE option: POS

ANALOGUE TYPE option: 4-20 mA

The function is used to output analogue signal of the current position (POS) or of the set-point value (CMD). Two output signal type (4-20mA, 0-20mA) can be selected. If the product selection has no feedback signal, this function is invalid.

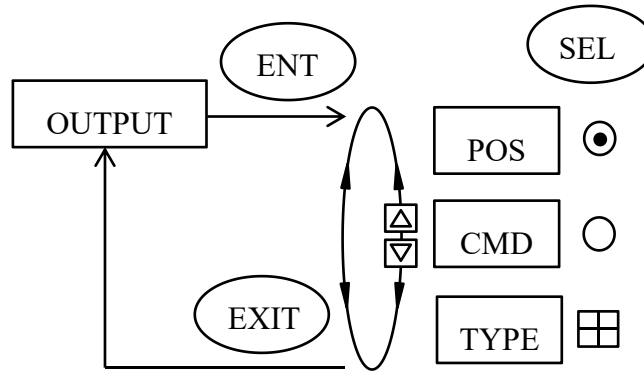

Figure 27. Operating structure OUTPUT

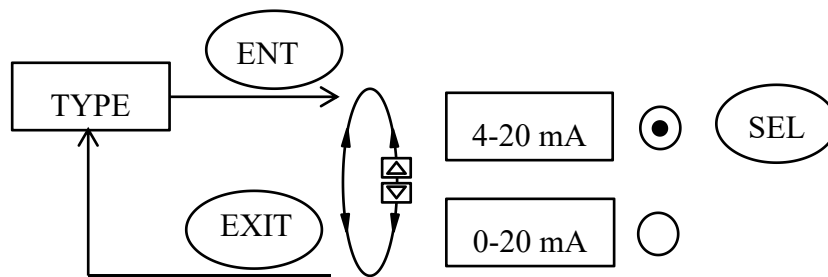

Figure 28. Operating structure OUTPUT TYPE

5.3.3.8. SIG ERROR

Factory setting:

SIG ERROR option: ERROR OFF

SIG ERROR SAFEPOS option: CLOSE

The function is used to detect the error of 4-20mA input signal, but cannot detect input signal of other types. The error condition is the value of 4-20mA input signal \leq 3.5mA. if opening the error detecting, the set-point value will instruct “ERROR” on the operating interface in the case of detecting the error signal. If the safety position is not enabled, the positioner will exhaust the actuator cylinder’s air.

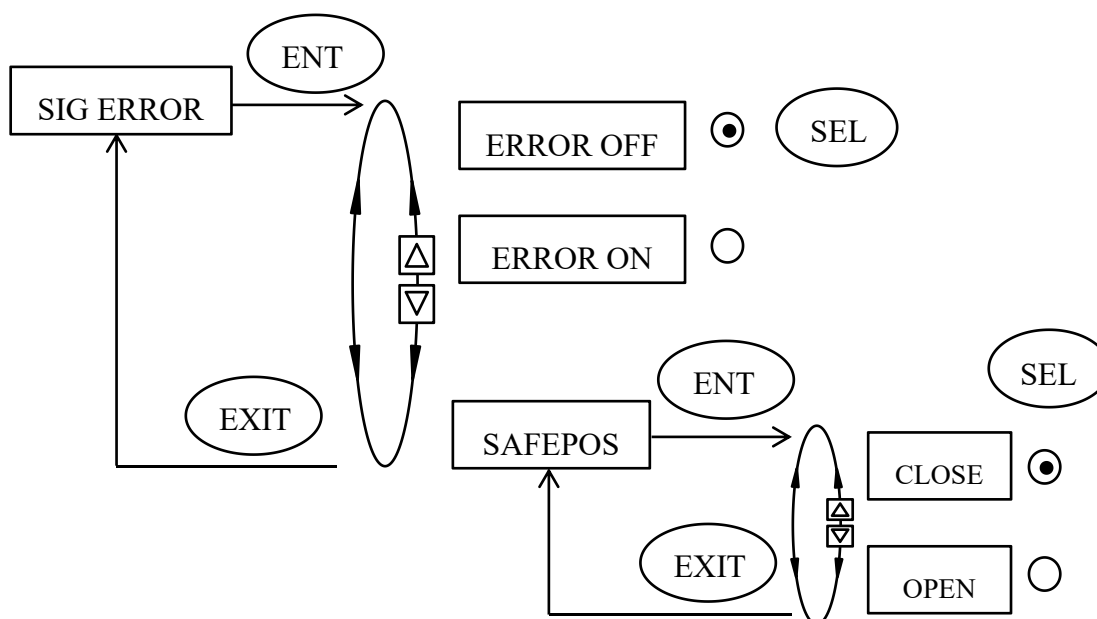

Figure 29. Operating structure SIG ERROR

Option	Description
ERROR OFF	Signal error detection is inactive.
ERROR ON	Signal error detection is active.
SAFEPOS	The SAFEPOS function is enabled by selecting OPEN and ERROR ON option when detecting the error signal.

Table 7. Option SIG ERROR

5.3.3.9. CAL USER

Factory setting:

CAL POS MIN: the AD value of minimum position by AUTO TUNE function.

CAL POS MAX: the AD value of maximum position by AUTO TUNE function.

CAL INPUT MIN for 4-20mA: 655

CAL INPUT MAX for 4-20mA: 3277

CAL INPUT MIN for 0-20mA: 0

CAL INPUT MAX for 0-20mA: 3277

The function is used to calibrate the scale value for valve stroke and input signal. And it is not recommended to be used for general users.

The value of calibration is a 12bit AD sample value in the system, the range is 0-4095.

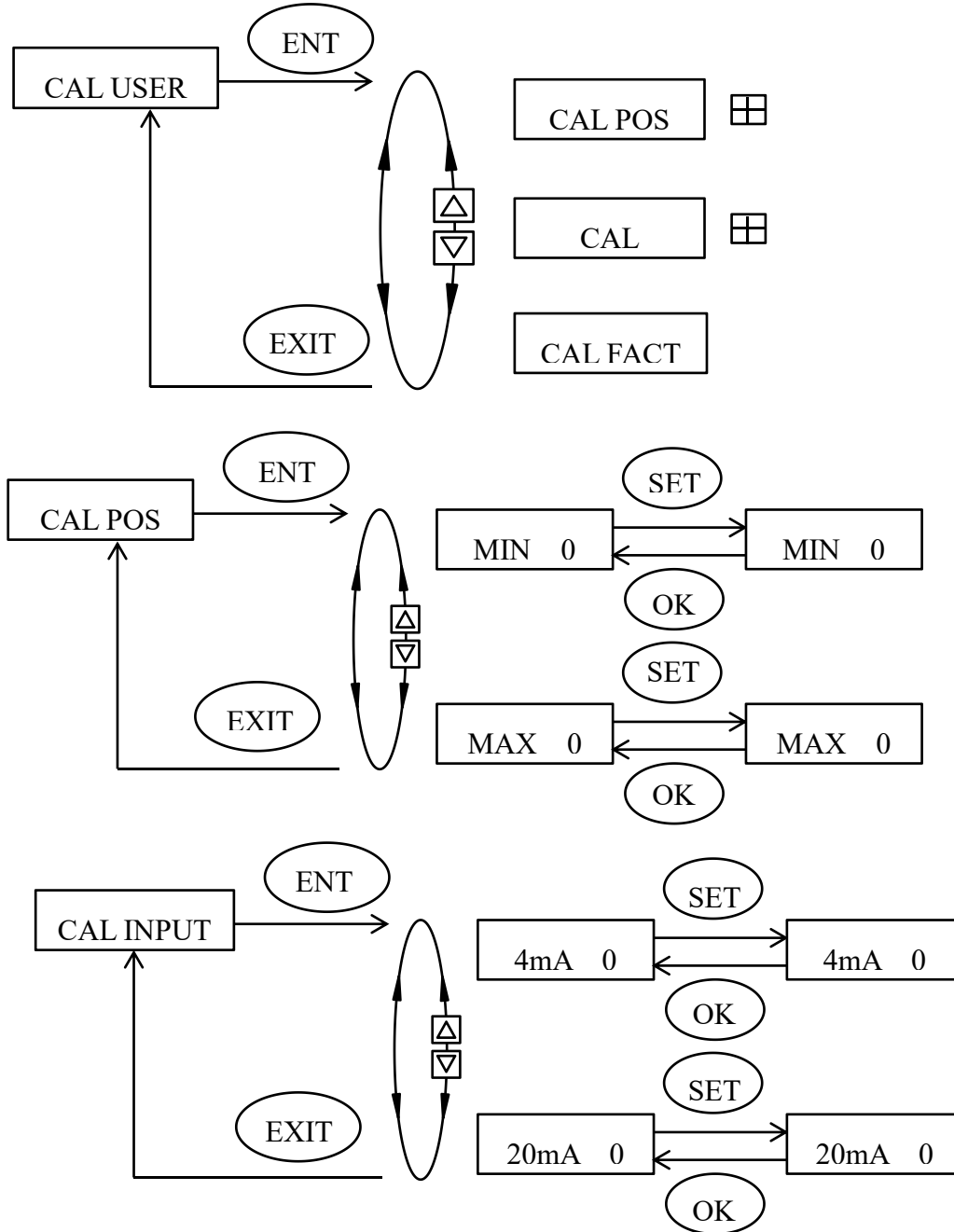

Press for approx.3s

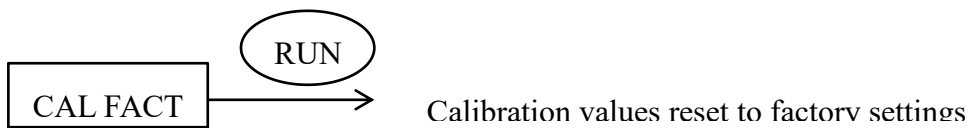

Figure 30. Operating structure CAL USER

Option	Description
CAL POS	Calibrating the scale values for valve stroke. When setting the MIN value, the actuator is fully close automatically. When setting the MAX value, the actuator is fully open automatically. The setting interface will display the present AD value of calibration and the lighted AD value of current position.
CAL INPUT	Calibrating the scale values for input signal. When setting the option, the actuator is fully deaerated and does not operate other functions. The setting interface will display the present AD value of calibration and the lighted AD value of current input signal.
CAL FACT	The parameters of CAL POS and CAL CMD reset to factory settings.

Table 8. Option CAL USER

When the system is running CAL POS or CAL INPUT function, user should watch the lighted changing value whether tends to be stable. The stable value can be judged according to the range of digital number changing less than 5 for a long time. After judging the stable value, press “OK” key on the display to record current changing value as the new calibration value. The recorded value may be different with the changing value which before recording.

NOTE!

Write down the current changing value before recording. The changing value to be recorded may be different with the value after being recorded. If the deviation of digital number between them is less than 3, the recorded value is available. Otherwise please run the calibration for the related value again.

5.3.3.10.MANU RATE

Factory setting:

GRADE : 2

The function is used for setting the rate for adjusting valve stroke in the manual mode.
The grade of adjustment rate: 1-5, 1 is the slowest adjustment rate, 5 is the fastest adjustment rate.

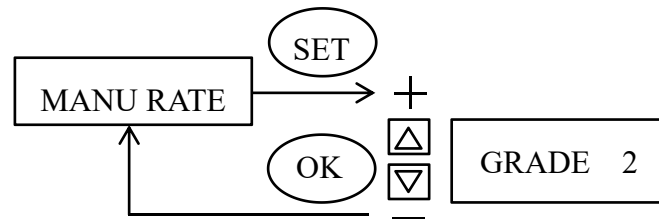

Figure 31. Operating structure MANU RATE

5.3.3.11.CODE

Factory setting:

Code: 0000

Protect options: none

The CODE function is to prevent some soft functions of the positioner being accessed.
If enabling the CODE function, it needs to input the code before opening the protected menu or running the protected functions.

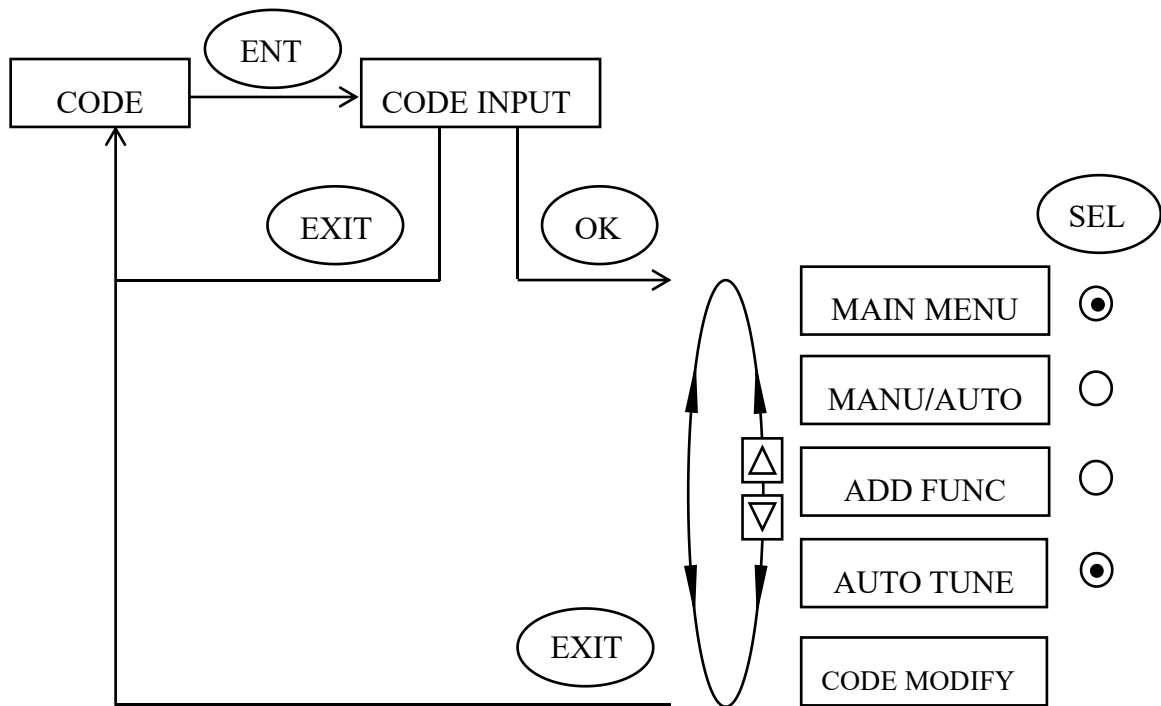

Figure 32. Operating structure CODE

Options	Description
MAIN MENU	Code protection for entering the main menu.
MANU/AUTO	Code protection for switching between automatic mode and manual mode.
ADD FUNC	Code protection for entering the auxiliary function menu.
AUTO TUNE	Code protection for running automatic adjustment.
CODE MODIFY	Modify the code for protected options and entering the CODE menu.

Table 9. Option CODE

5.3.3.12.SET FACT

All setting parameters reset to factory default value except the parameters of AUTO TUNE and CAL USER. To do so, enter the menu of auxiliary functions, then select the SET FACT option and press the “RUN” key for about 3s.

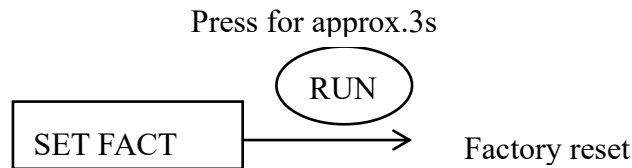

Figure 33. Operating structure SET FACT

5.3.4. LANGUAGE

The option is used to select the interface language.

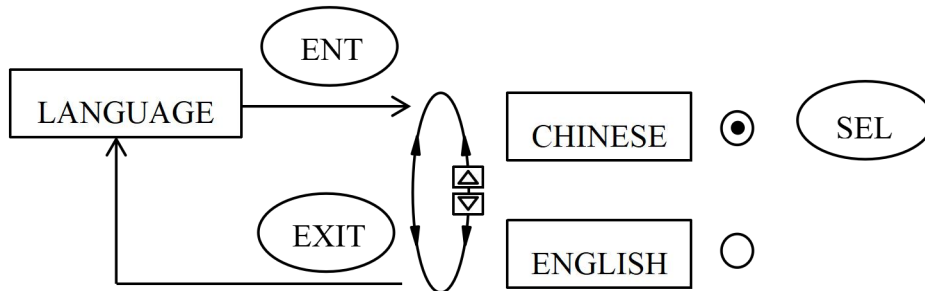

Figure 34. Operating structure LANGUAGE

6. Trouble shooting

1. Display does not light after the positioner powers up.

Make sure that the 24V DC power supply is normal.

Make sure that the power cables are connected correctly.

2. The positioner is unable to locate position. The valve cannot be fully opened or fully closed for a long time.

Make sure that the pressure of air supply meets the requirement.

Make sure that the setting value of limit stroke or dead band are not too small.

Make sure that the pneumatic connections of the positioner and actuator are not leaking.

7. Attention

1. The power supply voltage of the positioner is 24V DC $\pm 10\%$. Please check the power supply before connecting the power cable to the electrical terminal. Make sure that the power supply is cut off before connecting the power cable. If the product is damaged by high voltage, it will lose warranty.

2. Air supply use specification

1> The air pressure should be less than 0.7MPa.

2> Install the filter pressure reducer (5 μm filtration accuracy) in front of the air supply inlet of the positioner to prevent moisture or oil from infiltrating. In the situation of much oil in the air, it is suggested to additionally install oil separator (3 μm filtration accuracy) in front of the air supply inlet of the positioner. It is suggested to use the combination of SMC brand filter pressure reducer and SMC brand oil separator. Its model is AC20D-01CG-A. If the product is damaged due to the oil entering the product without oil

separator or filter pressure reducer being installed, it will lose warranty.

3. Waterproof electrical connectors use specification

- 1> The electrical connectors have foolproof design. Please connect the electrical female connector with the electrical male connector of the positioner according to the sign X1 and sign X2. Error connecting by strong force will destroy the electrical male connector.

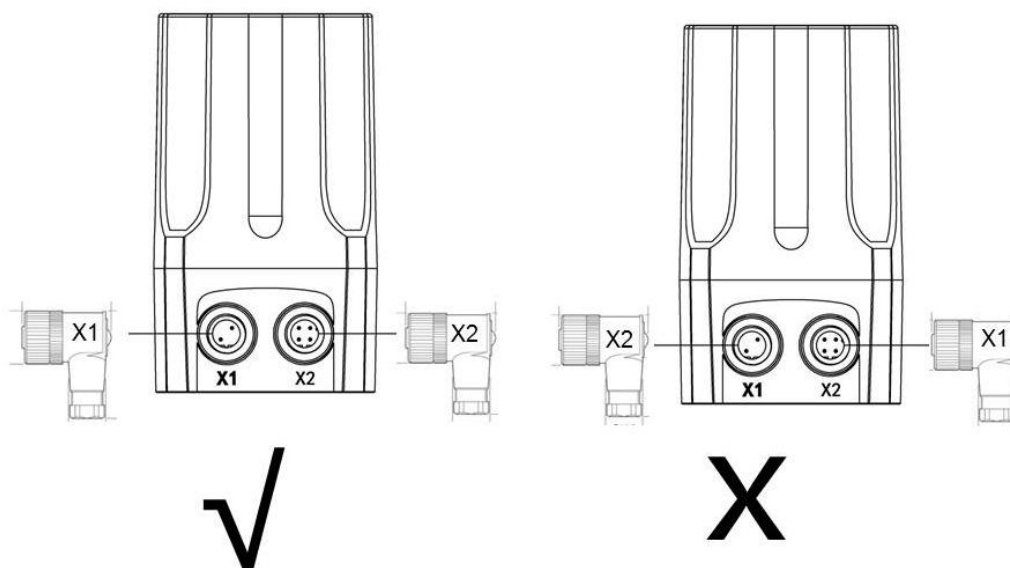

- 2> The cable diameter which is compatible with the waterproof electrical connectors is PG7 (4mm-6mm). Please use the multi - core cable with external insulation protection skin, otherwise the electrical connectors cannot achieve IP66 protection class.

Correct and error wiring ways are showing in the following pictures.

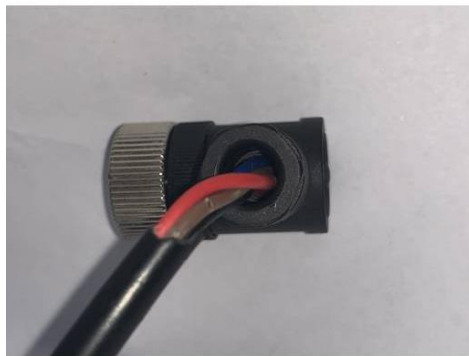

- 3> If the electrical male connectors are not used for a long time, to prevent water vapor or corrosive gases corroding the connector pins or entering the positioner inside, please screw on the electrical female connectors and block another side of the electrical female connectors with the silicone plugs. As shown below.

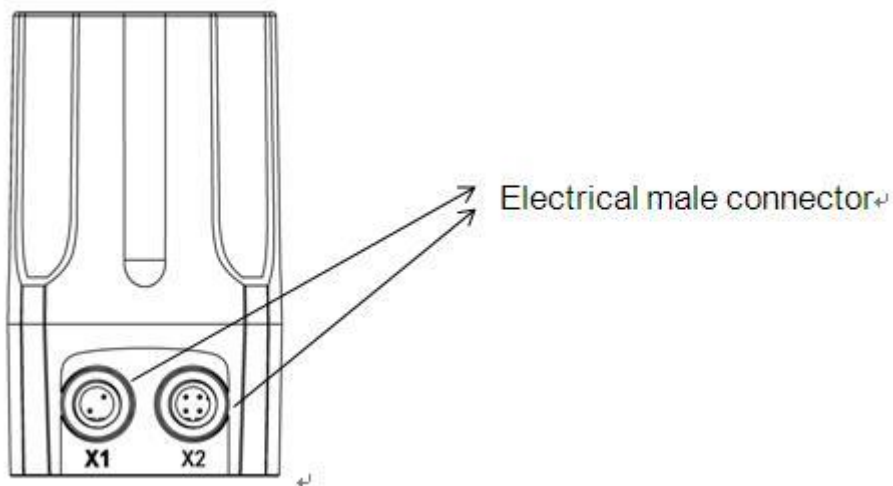

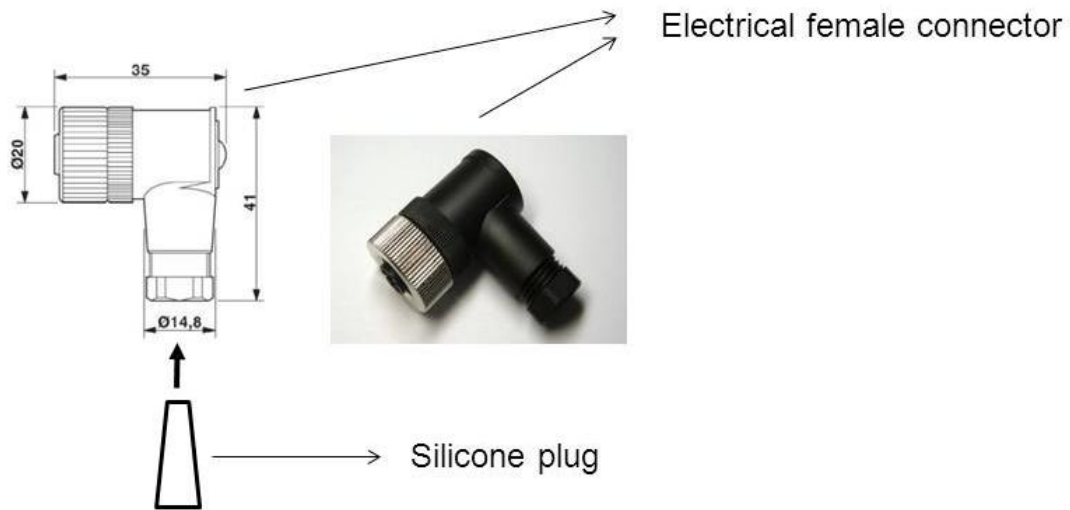

If the product is damaged by error operations for the waterproof electrical connectors, it will lose warranty.

4. If the product is damaged by the user removing the pneumatic connectors or the filter elements near the pneumatic connectors, it will lose warranty.

8. Warranty terms

1. If the product is found to have quality problems which are confirmed by our company staff, customers have after-sale services for product maintenance or free replacement in the warranty period. Service response time is 24 hours (excluding non-working days).
2. The warranty period of the product is based on the company's latest warranty policy, which is no less than 12 months after the sale.
3. The following situations for repaired product do not belong to the warranty range:
 - (1) The date is not in the warranty period.
 - (2) The product is disassembled without authorization and permit by the product company.
 - (3) The damage causes from the operation which is not according to the product

instruction manual or other human factors. Including but not limited to:

- 1> The product surface has collision scars.
- 2> Error wiring or error power supply makes the product damaged.
- 3> Parts and accessories are lost.
- 4> The product is damaged due to the oil entering the product without oil separator or filter pressure reducer being installed.
- 5> Error using the waterproof electrical connectors makes the product damaged.

(4) Force majeure (natural disasters) causes product failure or damage.

- 4. According to the actual situation, the product company offers the free or fee-based maintenance services outside the warranty range.
- 5. The terms become effective since the two sides signed a supply contract.

9. Selection and ordering data

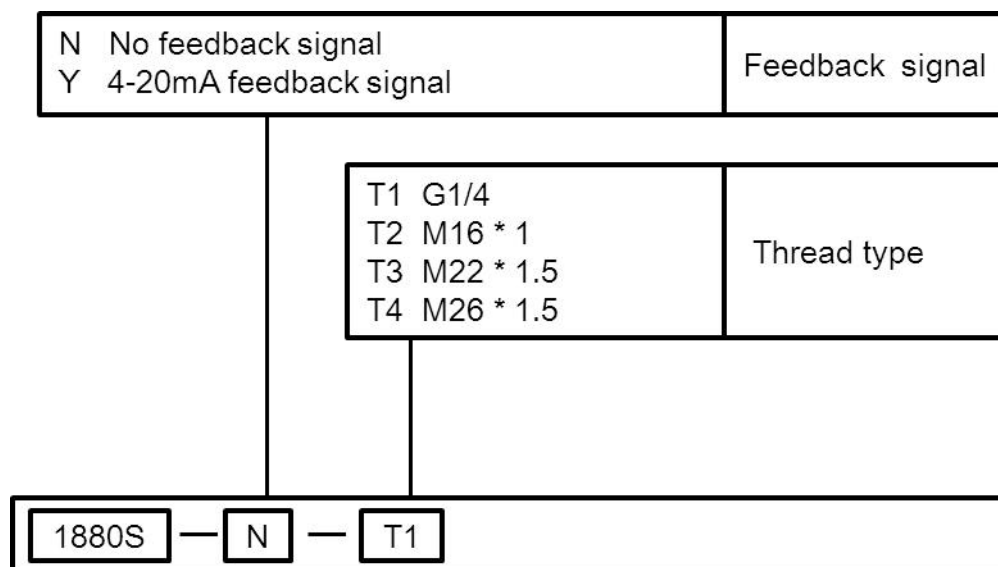

Remark:

The product is only used for single-acting line stroke actuator. Power off state is Safe.

It is suggested to match the actuator of 40-100 mm internal gas chamber diameter.

V251127

The changed contents of this manual are not noticed.

The Company reserves the final interpretation for related technical updating.

本说明书内容变更，恕不另行通知。

相关技术更新本公司保留最终解释权。

附件

智能阀门定位器气源要求

全系列产品

按照技术要求，全系列的智能阀门定位器气源要求为 3 级，提供符合气源要求的压缩空气，可以确保定位器的正常使用。

露点 3 级：露点为 -20°C 。（若定位器实际工作环境温度低于 -20°C ，则使用的压缩空气露点需相应低于定位器实际工作环境温度 -10°C ）

固体颗粒大小和密度 3 级： $5.0\text{mg}/\text{m}^3$ （对应粒径为 $5.0\mu\text{m}$ ），不允许有粒径大于 $5.0\mu\text{m}$ 的颗粒进入。

含油量 3 级： $1.0\text{mg}/\text{m}^3$ ，每单位立方米的空气累积油含量不超过 1.0mg 。

流程示例



图 1. 流程图

①在主管路中配备压缩空气干燥机，过滤掉压缩空气中产生的大部分水分，过滤后的压力露点可达到 -20°C ；

②选择任意与图 2 一致的调压过滤器组合安装在定位器管路的前端，安装时需过滤减压阀（空气过滤器）在前，油雾分离器在后，要求过滤器过滤粒径在 $5.0\mu\text{m}$ 以上的颗粒，最高残余油

含量 $\leq 1.0\text{mg}/\text{m}^3$ 。

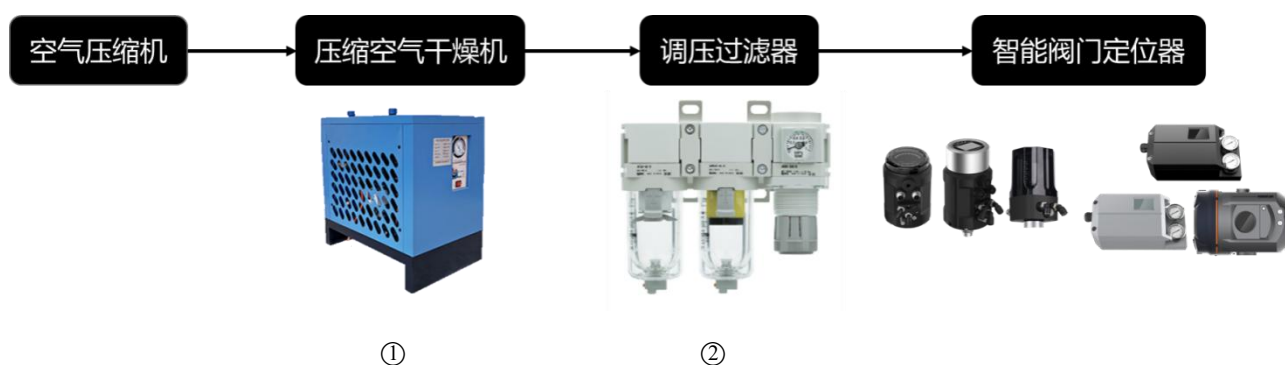

图 2. 调压过滤器组合

过滤器选型推荐

选型组合	<p>空气过滤器 + 油雾分离器 + 减压阀</p> <p>AF AFM AR</p>	<p>过滤减压阀 + 油雾分离器</p> <p>AW AFM</p>	
	<p>AC <input type="text" value="30"/> C- <input type="text" value="03"/> <input type="text" value="DG"/> - <input type="text" value=""/> - <input type="text" value=""/> - A</p> <p>① ② ③ ④ ⑤ ⑥</p>	<p>AC <input type="text" value="30"/> D- <input type="text" value="03"/> <input type="text" value="DG"/> - <input type="text" value=""/> - <input type="text" value=""/> - A</p> <p>① ② ③ ④ ⑤ ⑥</p>	
选型编号	SMC AC20C-02G-A	SMC AC20D-02G-A	SMC AC30D-02G-A

	入口侧压缩空气质量略低于定位器使用要求时	入口侧压缩空气质量符合定位器使用要求时	
基础参数	流体：空气 环境温度及使用温度：-5~60°C（未冻结） 耐压：1.5MPa 使用压力范围：0.05~1.0MPa 设定压力范围：0.05~0.7MPa 过滤精度：AW:5um、AFM：0.3um（捕集效率 99.9%） 杯体材质：聚碳酸酯 结构：溢流型		
选型参数	①主体尺寸：20 额定流量：200L/min 杯体保护罩：标准（钢带） 质量：0.39kg ②螺纹种类（无记号）：Rc ③接口管径 02：1/4 ④无记号：手动排水器 压力表 G：圆形压力表（带限位指示器） ⑤无记号：无附件 ⑥无记号：无特殊选择	①主体尺寸：20 额定流量： 150L/min 杯体保护罩：标准 （钢带） 质量：0.33kg	①主体尺寸：30 额定流量： 330L/min 杯体保护罩：标准 装备（聚碳酸酯） 质量：0.66kg
		②螺纹种类（无记号）：Rc ③接口管径 02：1/4 ④无记号：手动排水器 压力表 G：圆形压力表（带限位指示器） ⑤无记号：无附件 ⑥无记号：无特殊选择	
1 系列定位器*	●	●	/
IP 系列定位器*	●	/	●

*●为推荐的选择

注：过滤器处理空气额定流量需大于定位器的最大工作流量，在同一串联管路上存在多台定位器时则最大工作流量需相加计算（1系列最大流量 1500、1600： Q1-17L/min； Q2-95L/min； 1880S： 17L/min IP系列最大流量 IP5500: 155 L/min； IP6000/IP6500:187 L/min； IP6000d: 150 L/min 以上数据均为 0.6MPa 下测量所得）。

注意事项

1. 应视工况要求选择不同性能的调压过滤器，避免因工作环境的高温、低温、高压、腐蚀等原因导致调压过滤器失效,详见末尾附录选型表。
2. 定期巡查过滤器的使用情况，若使用频繁的工况应提高巡查次数，避免因过滤器滤芯堵塞导致的故障问题（故障举例：①过滤失效，导致定位器进入异物，致使定位器故障；②滤芯堵塞，导致气源供应异常，定位器无法正常工作等）。
3. 采用自动排水功能的调压过滤器需要避免排水孔的堵塞，定期巡查可避免过滤器故障导致滤杯内大量积水。手动排水的应视工况下过滤器的积水速率，定时人工排水。
4. 按照调压过滤器的使用说明，定期维护或更换不合格的产品，可避免不必要的故障出现。