

智能阀门定位器

IP5500 系列使用说明书

(安装使用前请仔细阅读使用说明书)

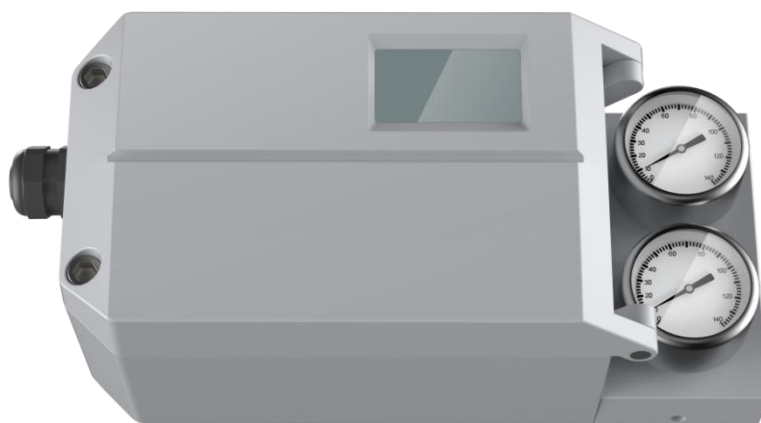

使 用 说 明 书 目 录

IP5500 系列智能阀门定位器

1. 概述	1
2. 一键自动初始化	1
3. 选型及订货数据	3
4. 主要技术指标	4
5. 接口说明	5
6. 机械尺寸	6
6.1. 外形尺寸	6
6.2. 安装支架尺寸	7
6.3. 直行程反馈杆尺寸	11
6.3.1. 反馈杆 A (带传动销)	11
6.3.2. 反馈杆 B (不带传动销)	11
6.4. 远传型传感器尺寸	12
7. 安装	13
7.1. 直行程 (常规型或远传型)	13
7.2. 角行程 (常规型或远传型)	26
8. 操作	32
8.1. 界面描述	32
8.2. 主界面显示和操作	33
8.3. 菜单和功能	34
8.3.1. 菜单显示和操作	34
8.3.2. 功能描述和操作	35
8.3.2.1. TYPE	35
8.3.2.2. INITA	35

8.3.2.3.	INITM	35
8.3.2.4.	CAL	36
8.3.2.5.	SDIR	36
8.3.2.6.	CHAR	37
8.3.2.7.	FREE	39
8.3.2.8.	DB	39
8.3.2.9.	LIM	40
8.3.2.10.	YDIR	41
8.3.2.11.	CUT	41
8.3.2.12.	POS	42
8.3.2.13.	FACT	43
8.3.2.14.	WP	44
8.3.2.15.	ACT	44
8.3.2.16.	REF	44
8.3.3.	初始化过程错误提示	44
8.3.4.	菜单选项或功能无法访问提示	45
8.3.5.	菜单功能选项汇总说明	45
8.4.	反馈信号	47
8.5.	流量调节	47
9.	故障检修	48
10.	保修条款	49



1. 概述

IP5500 系列智能阀门定位器和气动执行器配套使用。通过接收来自控制系统的 4-20mA DC 电流信号得到阀位控制设定值，同时采集位置传感器信号得到实际的阀位值，两者通过控制软件的计算处理，从而控制气动执行机构的进气和排气，驱动阀位到达设定点。

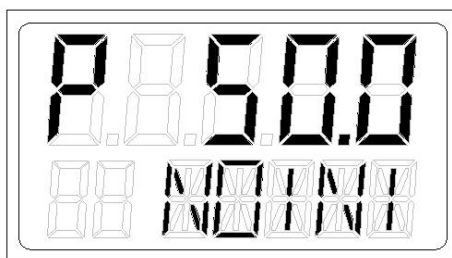

2. 一键自动初始化

1. 定位器安装前请详细阅读第 7 章节的安装说明。按照所描述的安装要求来安装定位器。请注意一些安装要点。例如，安装前确认定位器或远传型传感器反馈轴的初始位置。安装过程中切勿将反馈轴转动 360°。对于常规型直行程定位器，确认定位器外壳上平面和阀的主轴成直角。在阀门行程范围内，定位器反馈杆转动角度符合安装要求。
2. 将定位器安装到阀门上后，接上气源和电气线缆。确保气源压力能完全打开阀门。通过输入 DC 24V 电压给定位器上电。
3. 定位器上电后，系统在没完成初始化功能前处于未初始化状态。显示标志为 NOINI，界面第一行显示传感器百分比值。如下图所示。



在此状态下，操作   键可打开或关闭阀门。将阀门全开和全闭，观察界面上显示的传感器百分比值。确保在整个阀门行程范围内，传感器百分比最小值 $\geq 2\%$ ，传感器百分

比最大值 $\leq 98\%$ 。否则，需要重新调整安装位置使直行程反馈杆或角行程适配器在有效范围内动作。另外，要求传感器最小最大百分比差值大于 16%。

4. 定位器出厂前已设置好执行机构类型。用户只需一键执行自动初始化 (INITA) 功能来完成对阀门的匹配。在初始界面 (NOINI) 或手自动模式界面长按  键 3 秒左右开始运行自动初始化。初始化完成后，LCD 上显示 FINSH，按  键退出。退出后，系统进入手动模式界面，再次按  键可切换到自动模式。此时用户可通过 4-20mA 信号来控制阀门开度。自动初始化过程中由于某些原因，系统会在功能选项栏显示错误提示。并中断初始化。错误提示说明及处理方法详见 8.3.3 章节。

3. 选型及订货数据

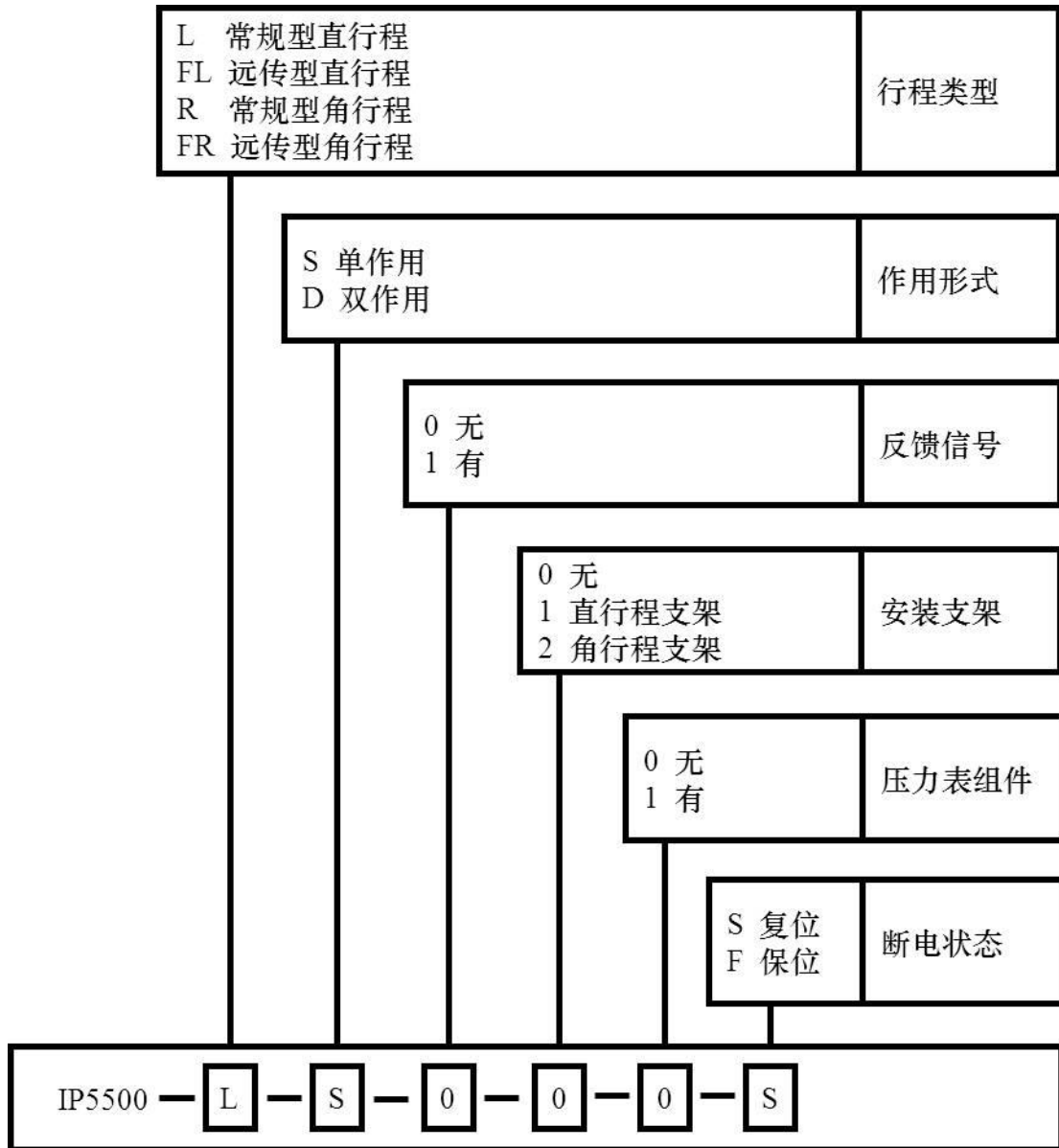

4. 主要技术指标

外壳材质	铝合金
电源	24V DC \pm 10%
信号输入	4~20mA DC
环境温度	0~50°C
气源要求	符合 ISO 8573-1 <ul style="list-style-type: none"> ● 固体颗粒大小和密度 3 级 ● 露点 3 级 ● 含油量 3 级
抗振动性	0.15mm, 10Hz~60Hz, 20 次循环/轴 20m/s ² , 60Hz~500Hz, 20 次循环/轴 整个控制阀连续运行时的推荐范围 \leq 20 m/s ² , 无谐振峰值
气源压力	0.14~0.7MPa
流量	75L/min (Sup=0.14MPa)
基本误差	\leq 0.5%
回差	\leq 0.5%
电气接口	M20 \times 1.5
气动接口	G1/4
重量	1.5 kg
防护等级	IP69K

5. 接口说明



图 1. 接口说明

电气接口	描述
IN+	4-20 mA 设定信号 +
IN-	4-20 mA 设定信号 -
DC 24V+	电源 DC 24V +
DC 24V-	电源 DC 24V -
OUT+	4-20 mA 反馈信号 +
OUT-	4-20 mA 反馈信号 -

气动接口	描述
SUP	气源进入
OUT1	先导气口 1
OUT2	先导气口 2, 双作用时使用

注意:

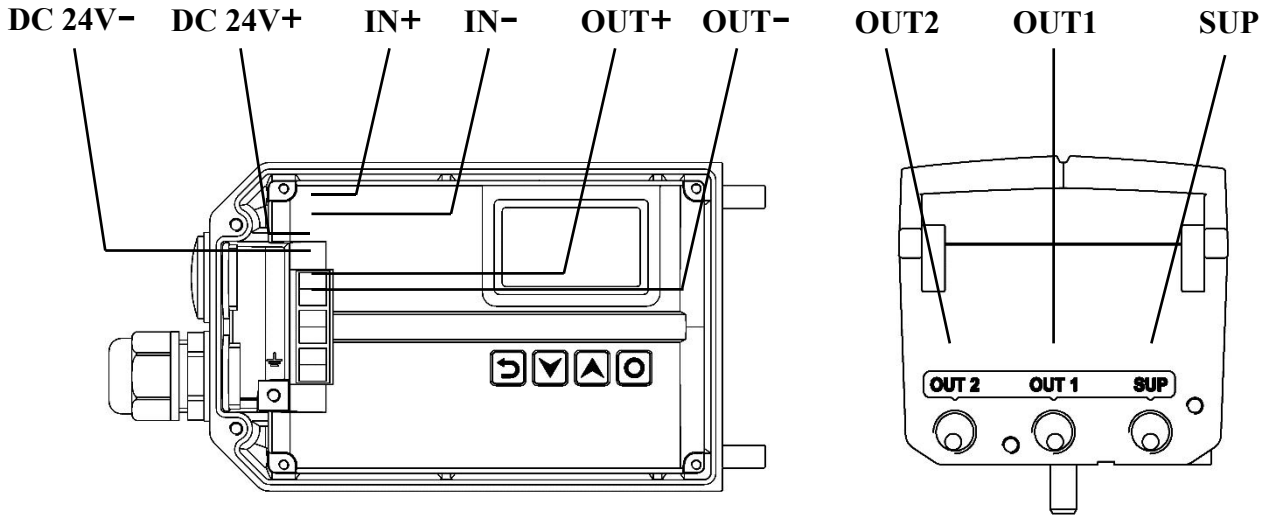
- 电气线缆必须用屏蔽双绞线或屏蔽线。并将线缆屏蔽层一端连接设备外壳 \perp 处的螺钉或壳体内 \perp 处的螺钉，另一端连接大地。从而使设备有效接地，防止电磁干扰。
- 电气线缆铺设要远离强磁场环境。
- 请在设备断电情况下连接或拆卸电气线缆。

6.2. 安装支架尺寸



图 3. 常规型直行程安装支架



图 4. 远传型直行程安装支架

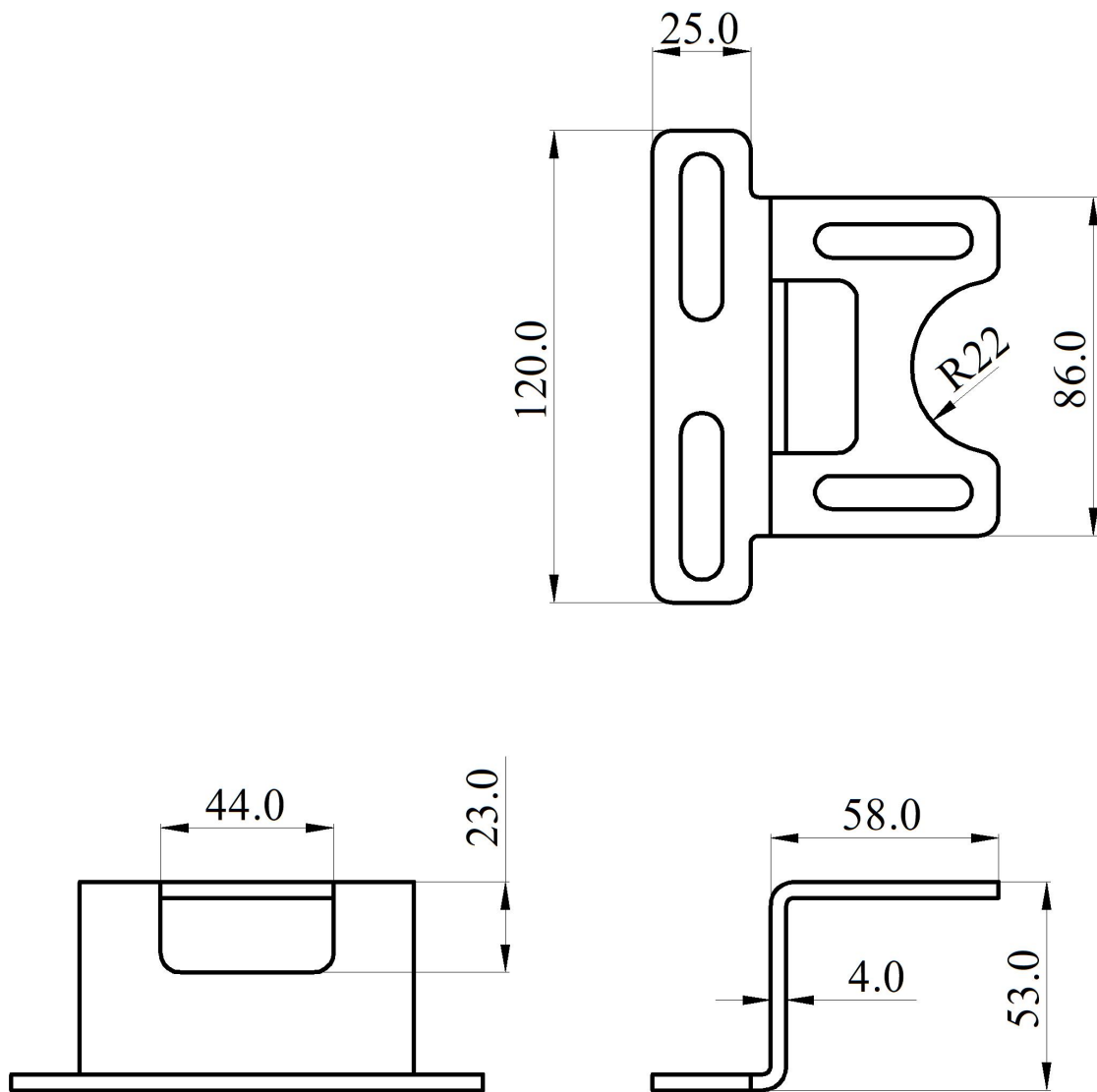

图 5. 角行程安装支架 A 型

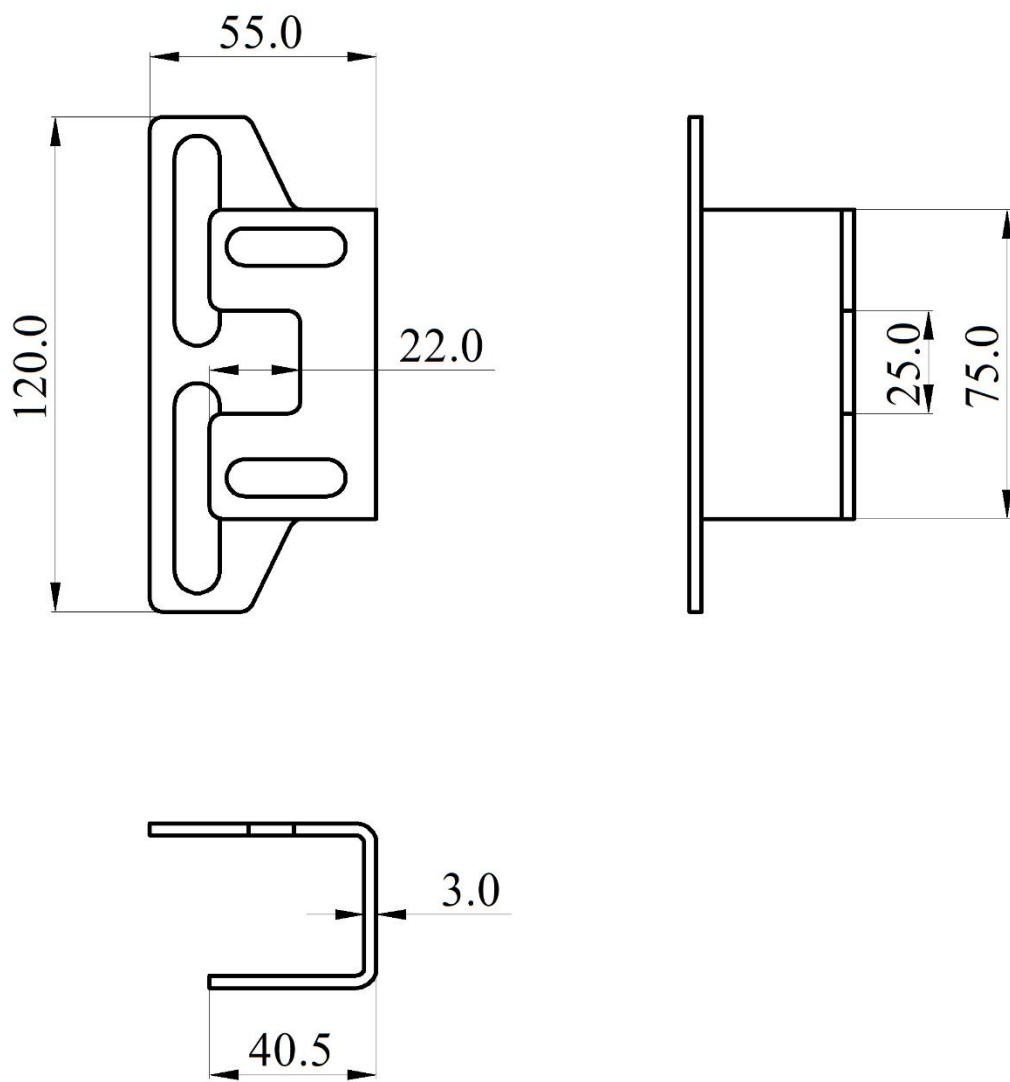

图 6. 角行程安装支架 B 型

6.3. 直行程反馈杆尺寸

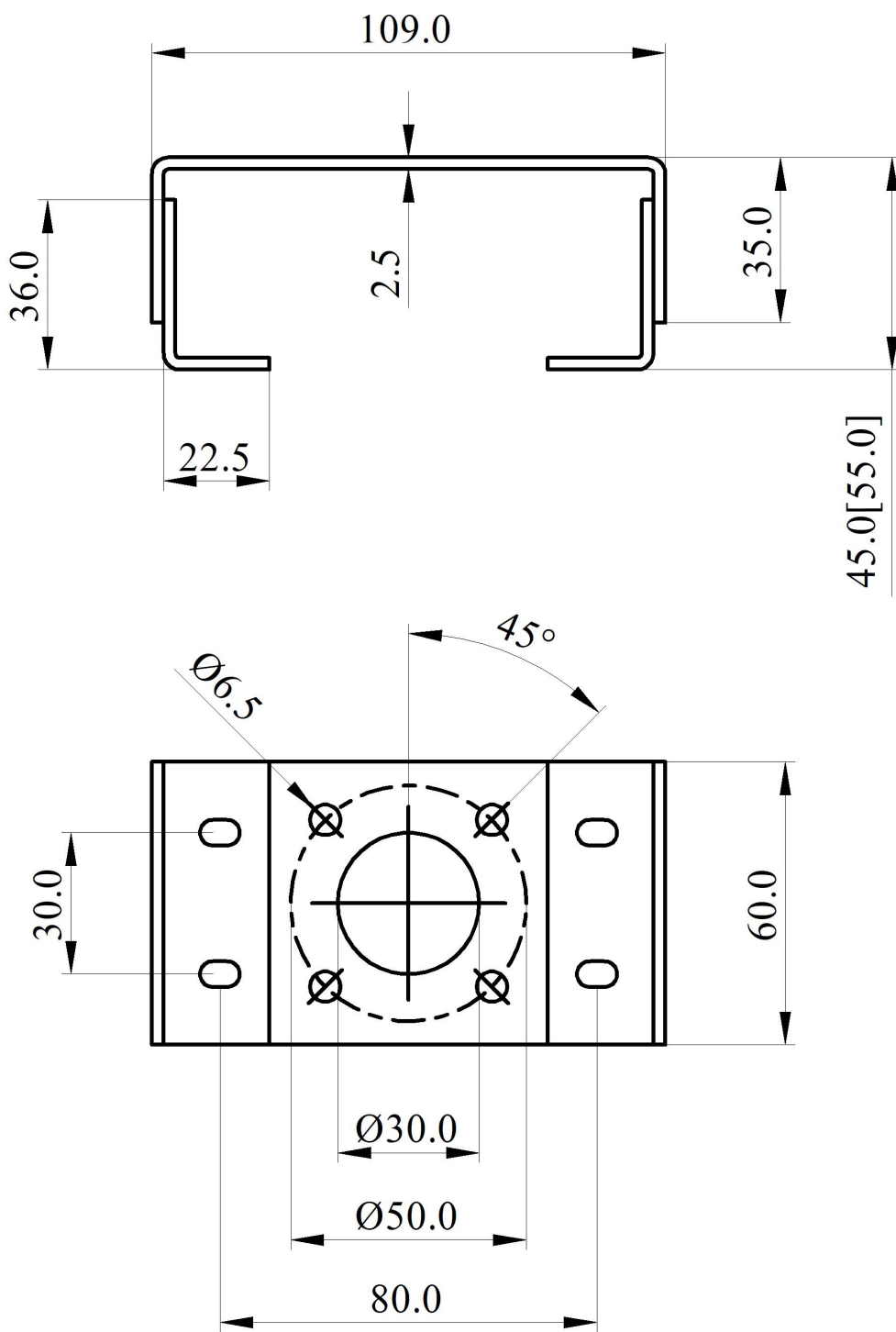
6.3.1. 反馈杆 A (带传动销)

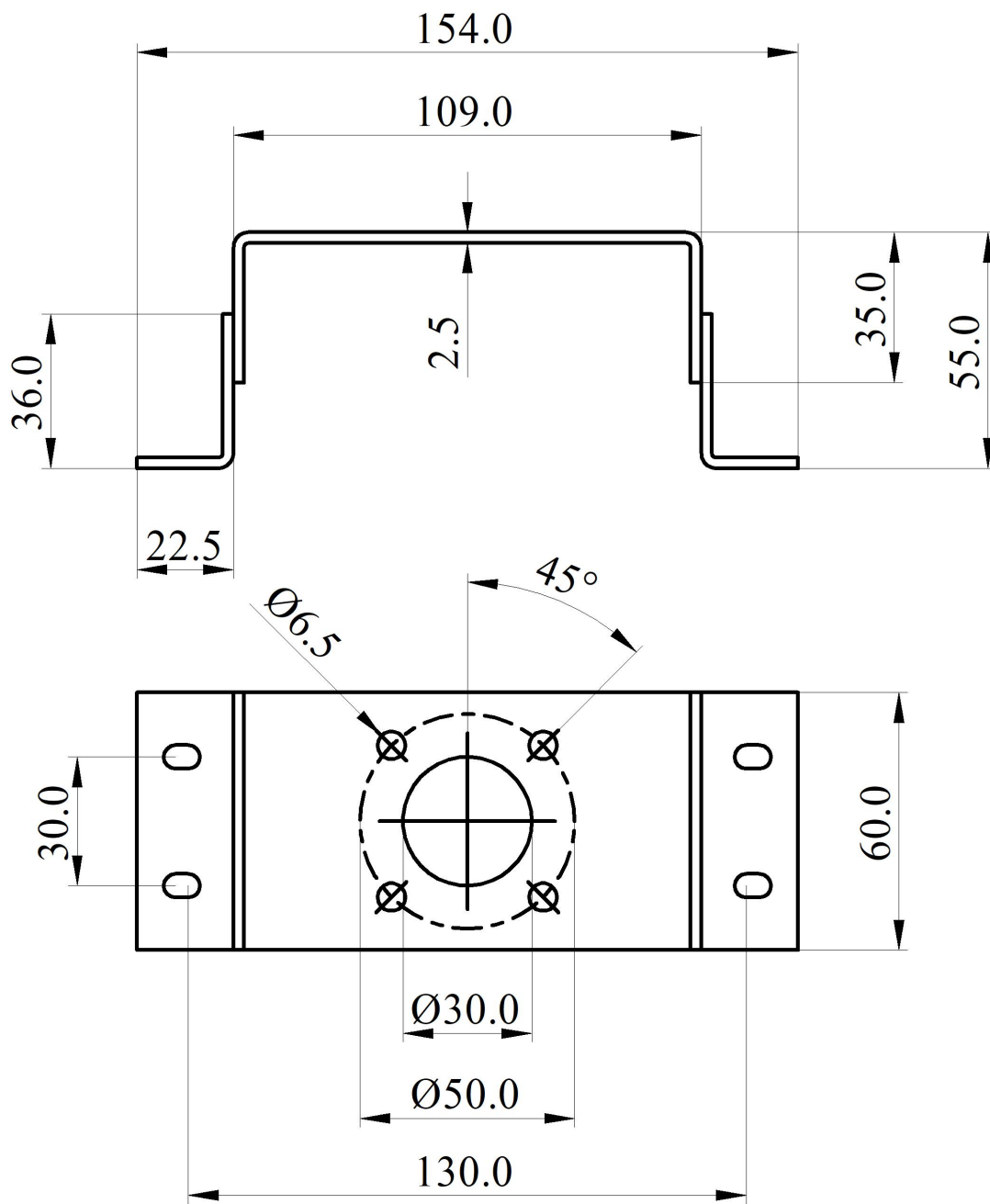

图 7. 反馈杆 A 尺寸

6.3.2. 反馈杆 B (不带传动销)

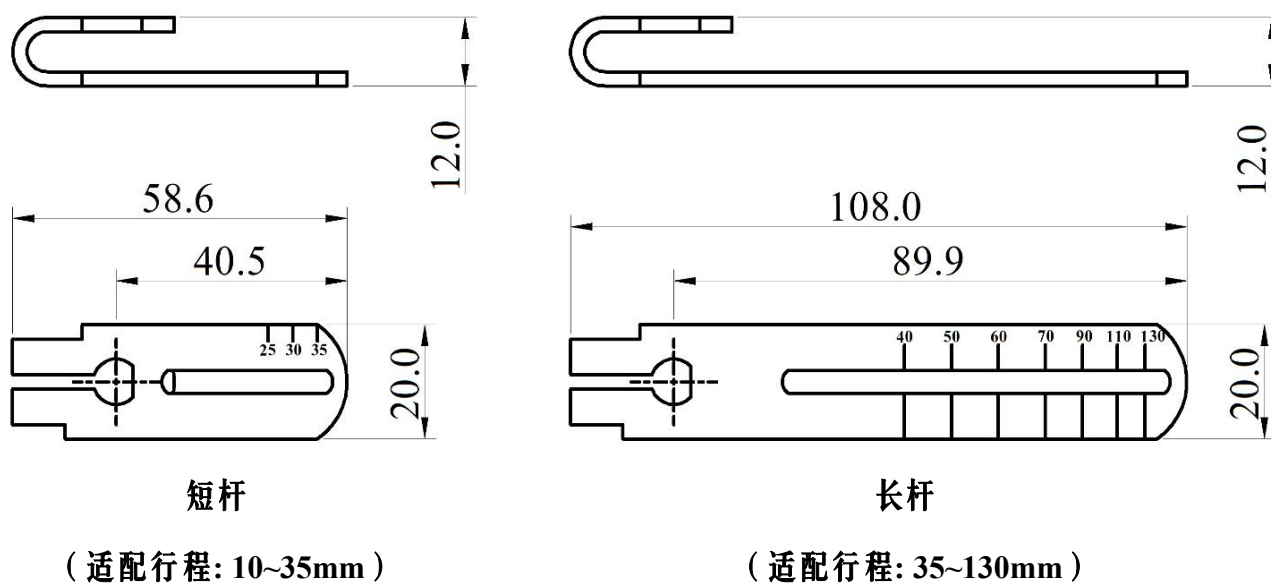

图 8. 反馈杆 B 尺寸

6.4. 远传型传感器尺寸

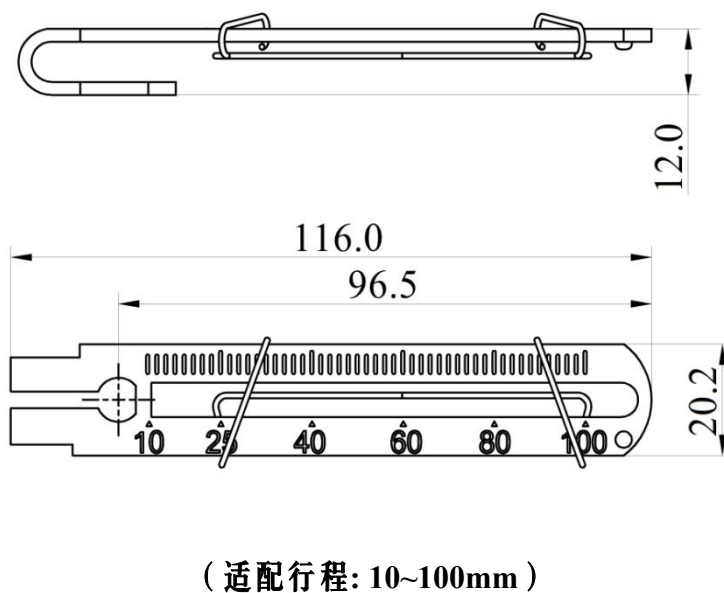

图 9. 远传型传感器尺寸

7. 安装

7.1. 直行程（常规型或远传型）

直行程执行机构安装组件			
序号	名称	数量	注意
①	U 型杆	1	工作过程中使反馈杆发生旋转
②	夹板	1	在执行机构上安装 U 型杆
③	M6 内六角螺钉	2	M6×25
④	M6 弹簧垫圈	2	防止螺钉松动
⑤	反馈杆 A 或 B	1	安装在定位器主轴上
⑥	M6 内六角螺栓	1	M6×20, 搭配方形螺母
⑦	直行程安装支架	1	连接定位器与执行器
⑧	M8 六角头螺栓	2	M8×10
⑨	M8 弹簧垫圈	2	防止螺栓松动
⑩	M8 平垫圈	2	保护接触平面
⑪	匹配反馈杆 B 的传动销	1	安装在阀的主轴上

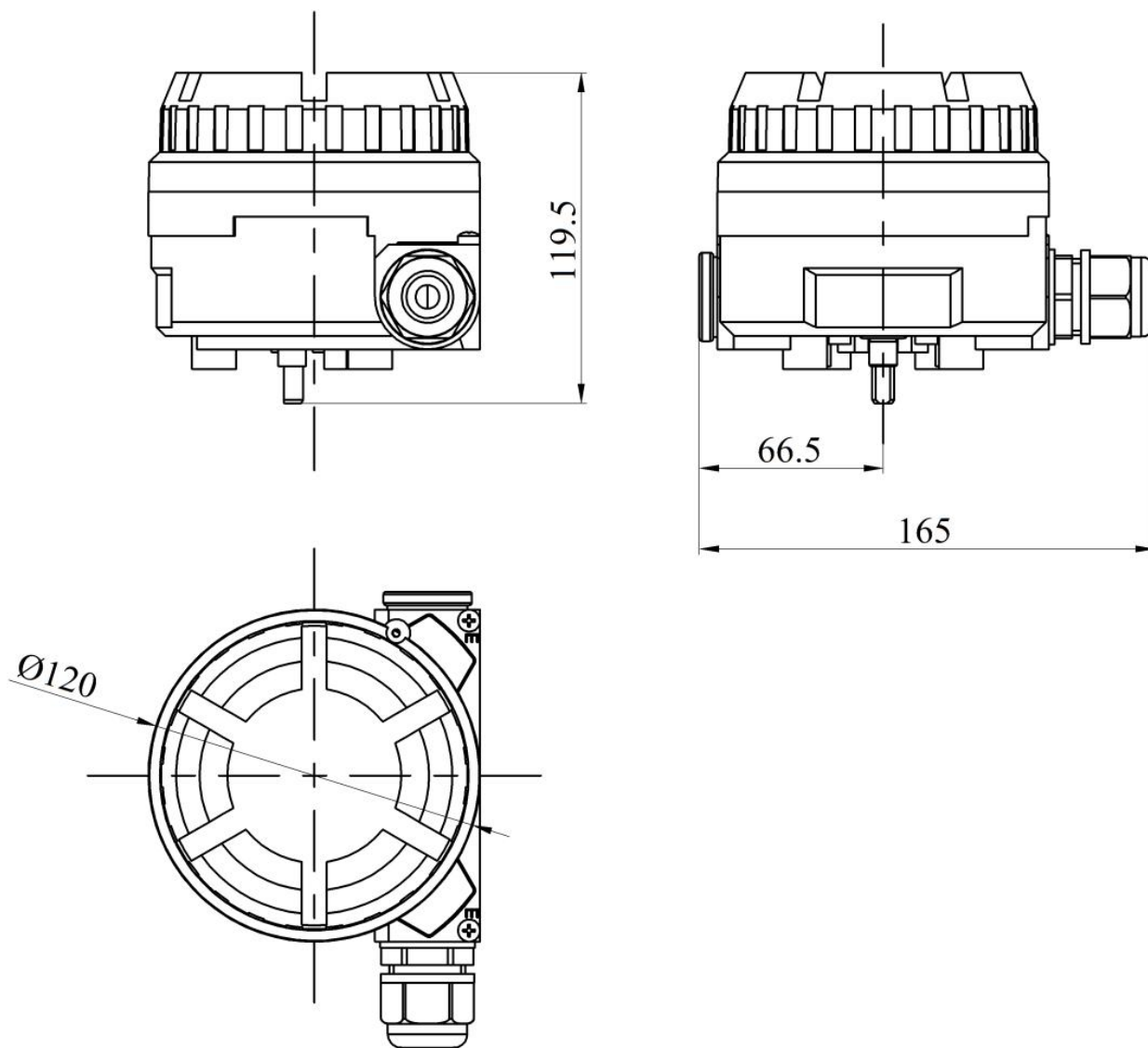
1. 确认定位器或远传型传感器反馈轴的初始位置。



图 10. 反馈轴初始位置

转动反馈轴，将反馈轴上的指针指向图 10 所示箭头的方向。箭头的方向定义为初始位置。给定位器上电，在初始界面（NOINI）观察传感器百分比值，确认数值在 40~60% 之间。如果不是，将反馈轴转动 360°，再次确认。确认之后，将定位器断电。

2. 把匹配反馈杆 A 的 U 型杆或匹配反馈杆 B 的传动销安装到执行器上。

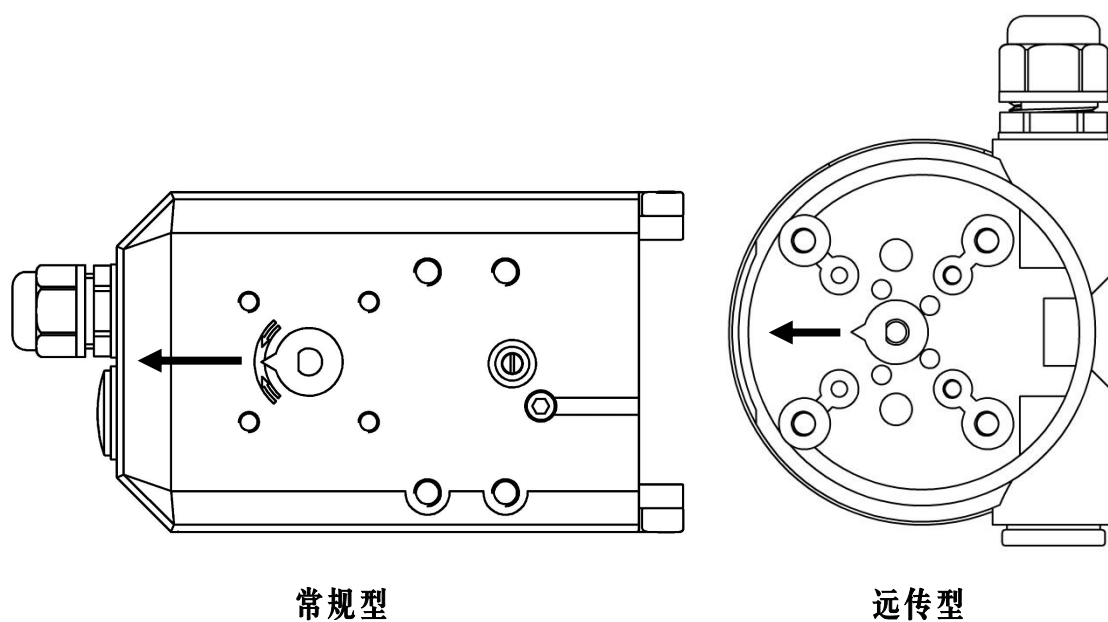

图 11. U 型杆安装



图 12. U 型杆安装方向

用内六角螺钉③和弹簧垫圈④把 U 型杆①和夹板②固定在执行器的中心轴上，使用内六角扳手拧紧螺钉。

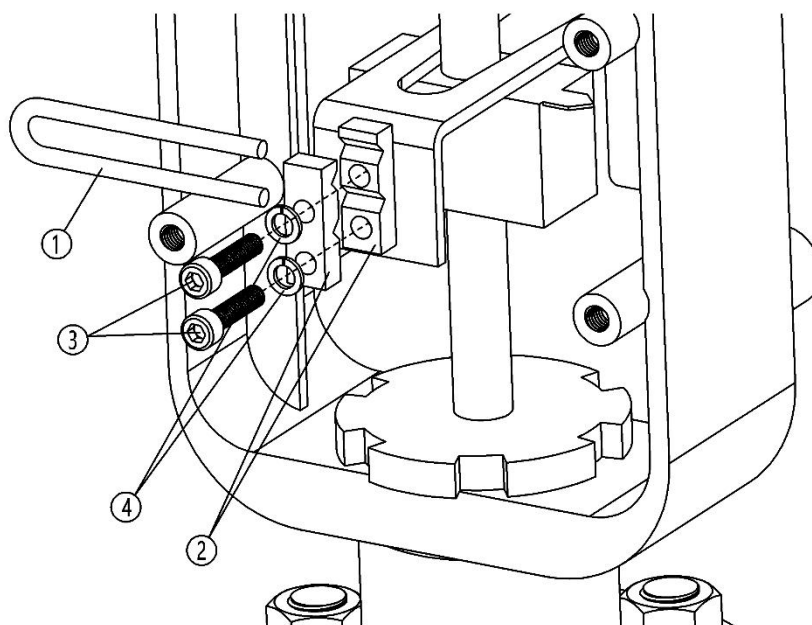

图 13. 传动销安装

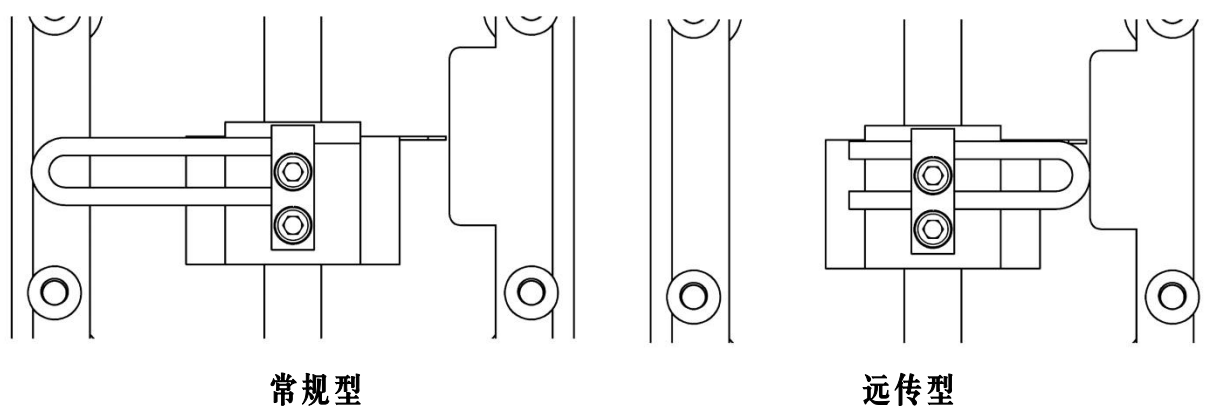
将传动销⑪安装到阀的主轴上。反馈杆 B 的插槽高度为 6.2 mm。因此用户如果未使用提供的传动销，需注意使用传动销的直径为 6 mm，传动销与阀的主轴上的螺纹大小须一致。

3. 安装匹配反馈杆 A 的传动销。

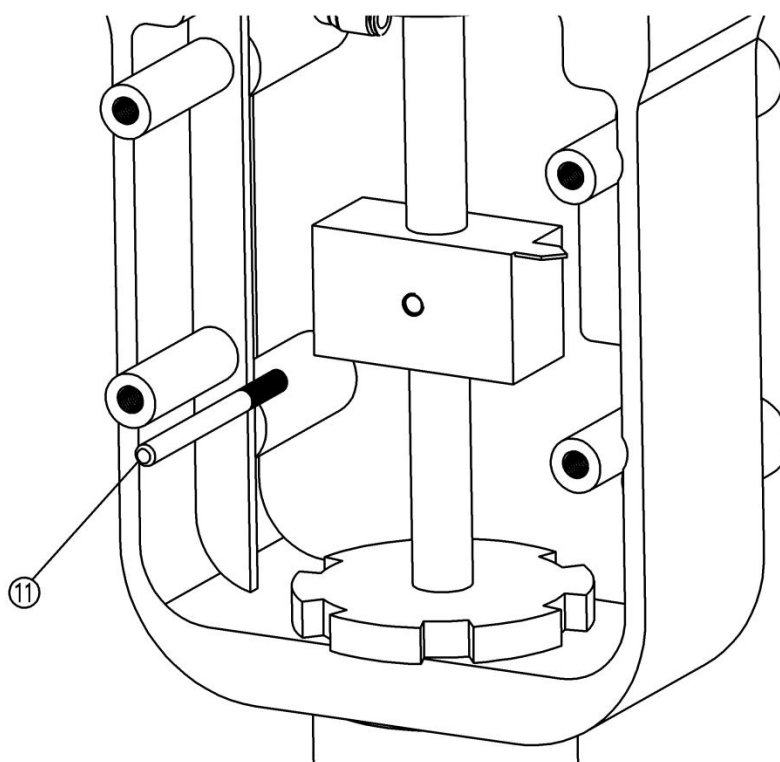

图 14. 匹配反馈杆 A 的传动销安装

根据阀门实际行程选择上图对应的反馈杆。将传动销安装至反馈杆上的对应的行程刻度处。如果传动销不对应标尺刻度安装，当阀门动作时，可能会造成反馈杆损坏。比如对于 100mm 行程的阀门，将传动销装在刻度 40 处，当阀门动作时，可能会使反馈杆受力变形。如果阀门行程不在反馈杆 A 的行程范围内，请咨询厂家。

4. 把反馈杆和直行程安装支架安装到定位器或远传型传感器上。

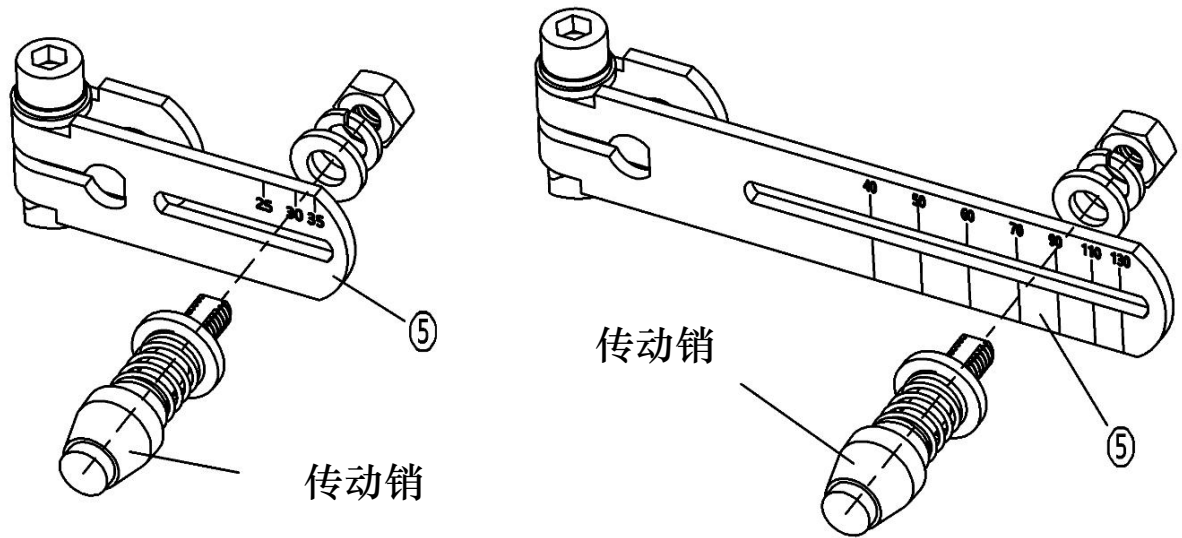

图 15. 反馈杆 A 和安装支架安装 (常规型)



图 16. 反馈杆 A 和安装支架安装 (远传型)

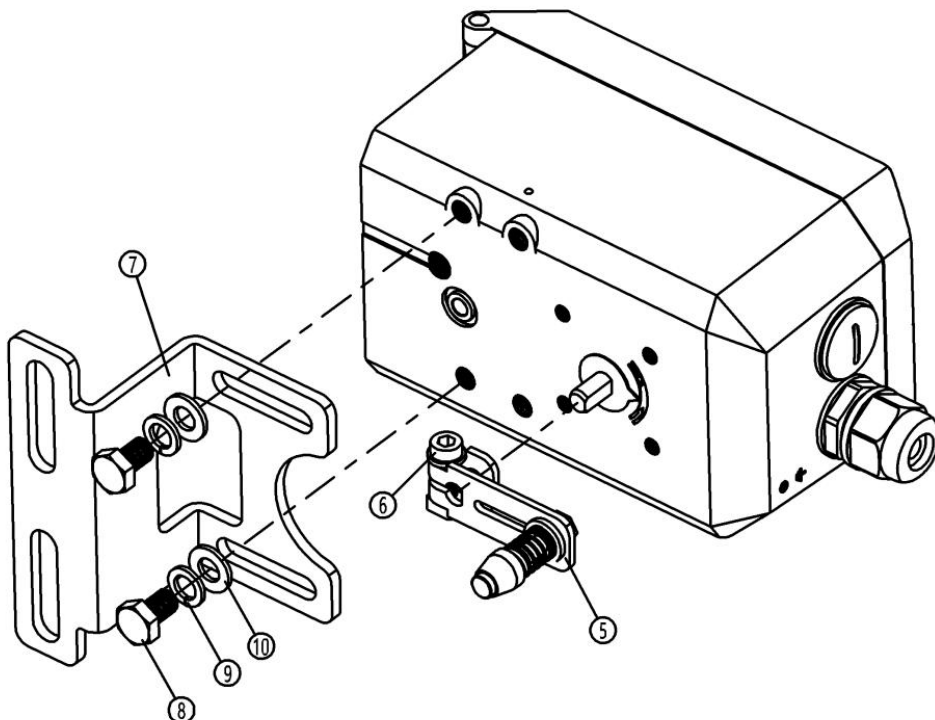

图 17. 反馈杆 B 和安装支架安装 (常规型)

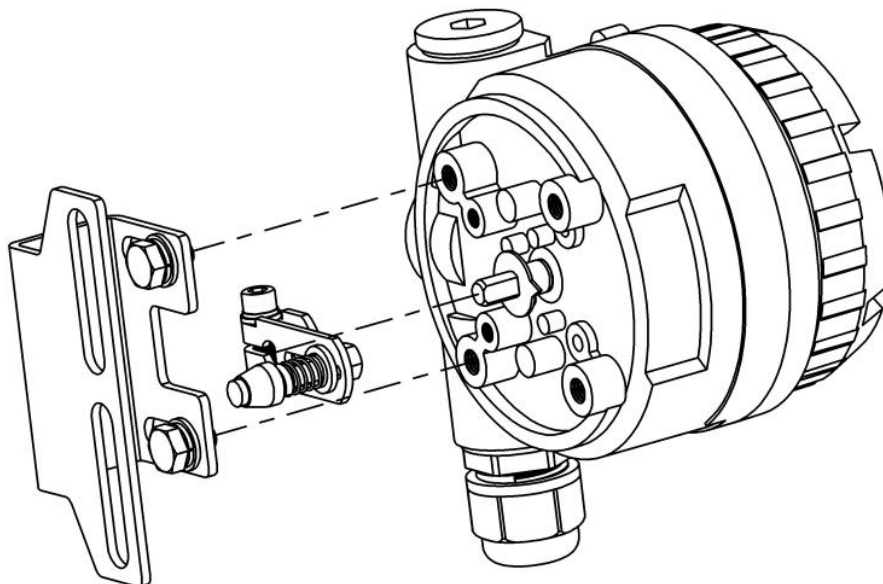

图 18.反馈杆 B 和安装支架安装（远传型）

- 把反馈杆 A 或 B⑤连接到定位器或远传型传感器后部的反馈轴上。
 - 观察箭头标记，检查反馈杆行程是否在可操作范围内。
 - 使用内六角扳手拧紧内六角螺栓⑥。
 - 用六角头螺栓⑧、弹簧垫圈⑨及平垫圈⑩把直行程安装支架⑦预紧在定位器或远传型传感器上。
5. 把直行程安装支架固定于执行器上。

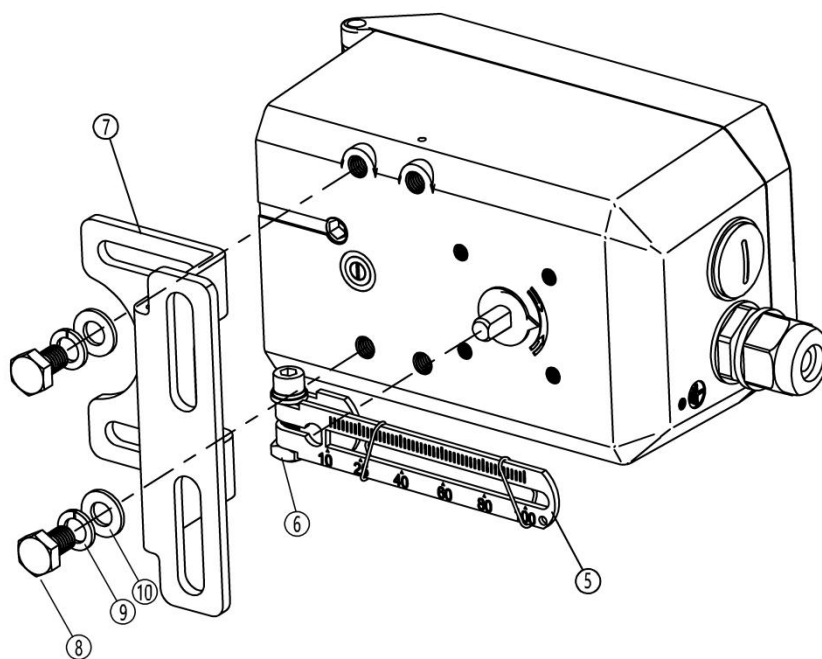

图 19. 阀门行程中点

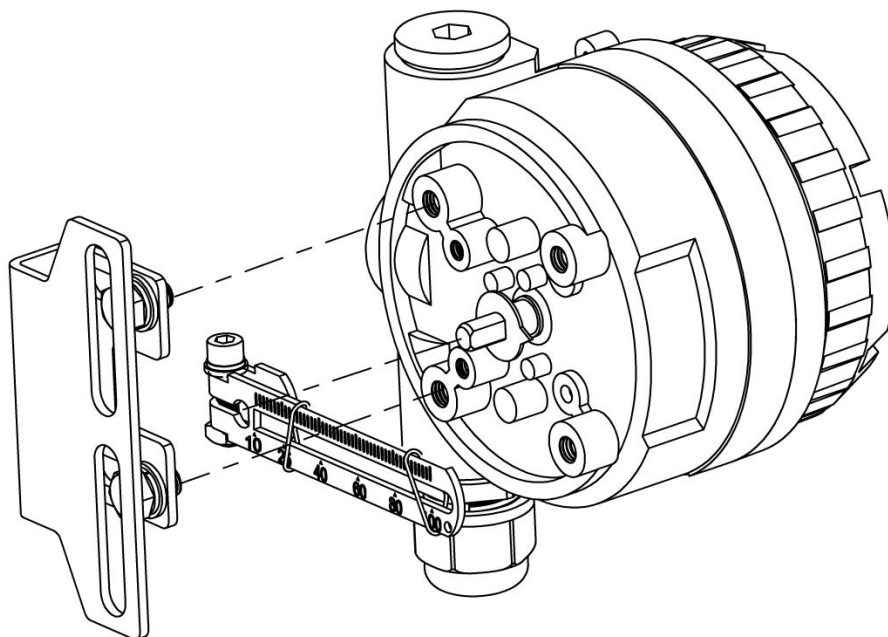

图 20. 反馈杆 B 和传动销连接

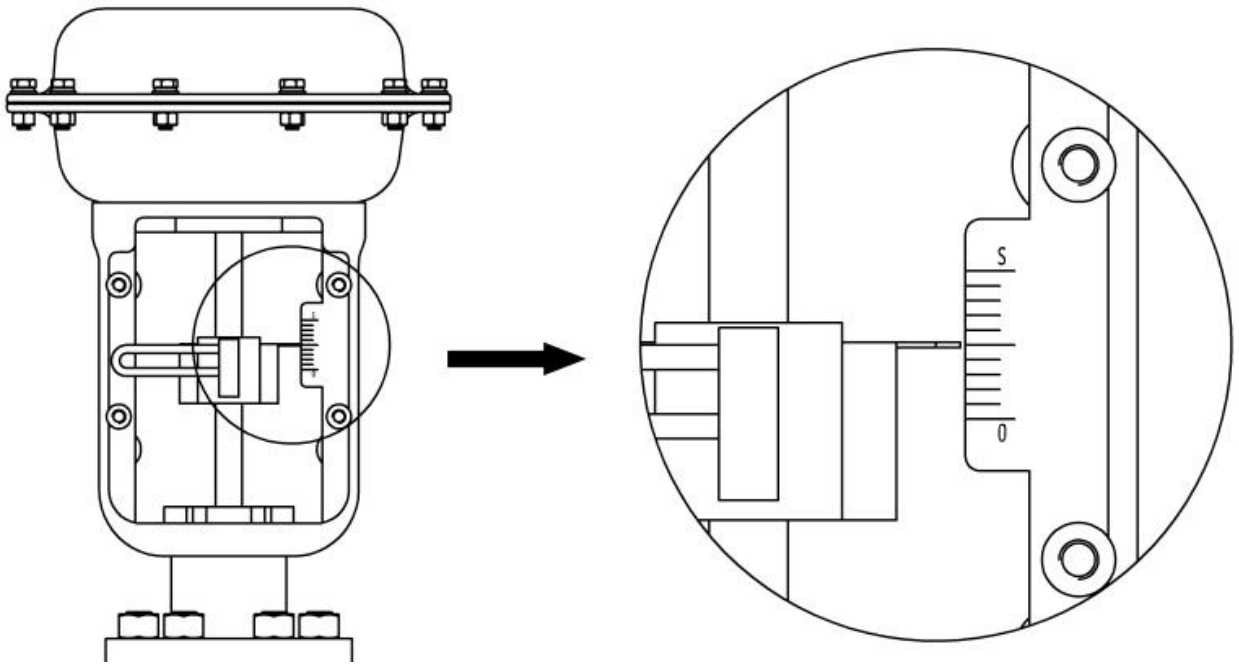

图 21. 与执行器安装 (反馈杆 A)

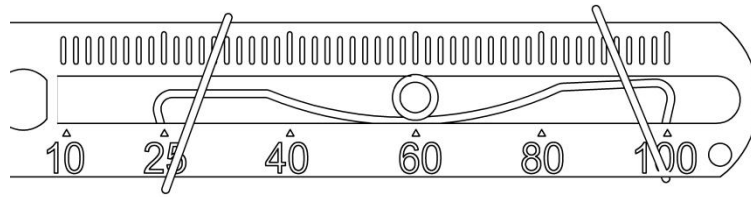

图 22. 与执行器安装 (反馈杆 B)

- 给阀门气缸通气，依据阀门上的行程标尺将阀位调到行程中点，如图 19 所示。
- 对于反馈杆 A，使直行程安装支架⑦贴住执行器，反馈杆⑤的头部进入 U 型杆①。对于

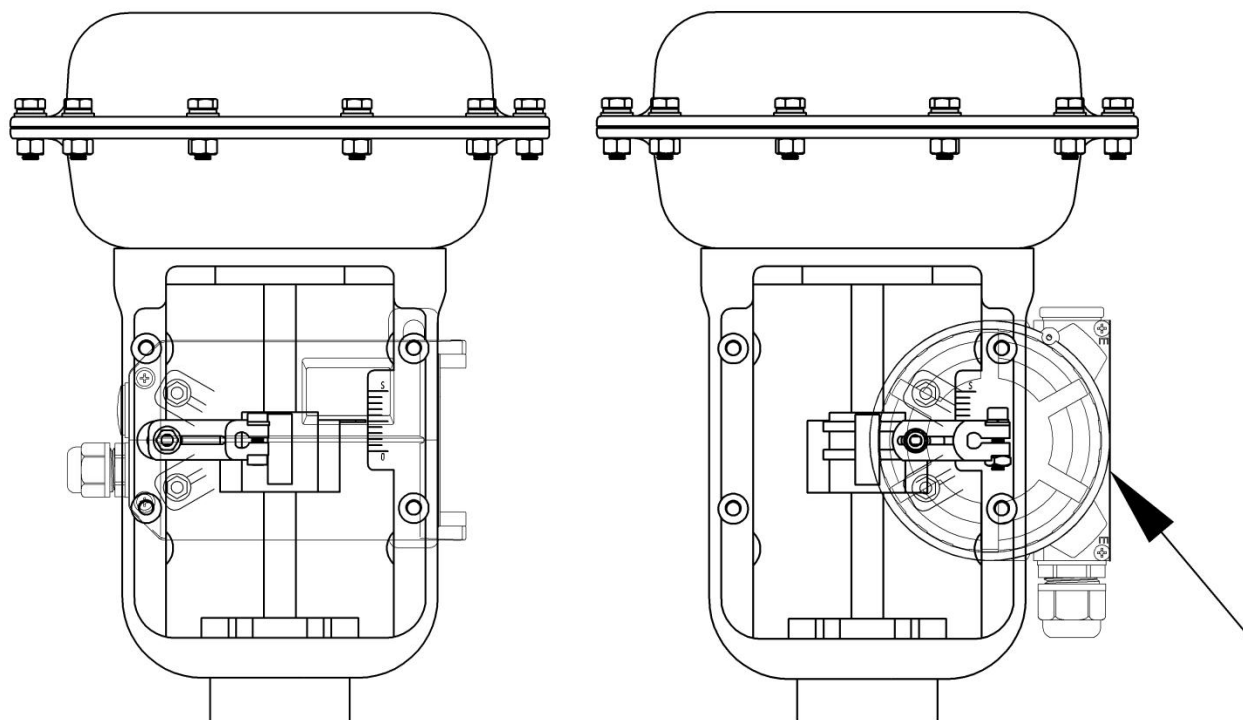
反馈杆 B，把传动销⑪插入到反馈杆 B 插槽内的固定弹簧上，如图 20 所示。调整位置，目测确认阀的主轴和反馈杆成直角。如无法成直角则按实际情况安装。

- 反馈杆全行程摆动角度建议在 40° ~ 90° 之间。可通过调整反馈杆传动销与定位器或远传型传感器转轴间的距离（角度转动半径）来改变摆动角度。
- 对于常规型直行程定位器，确保定位器外壳上平面和阀的主轴成直角。对于远传型直行程定位器，确保传感器壳体箭头（图 21 和图 22 右侧所示）所指平面与阀的主轴互相平行。否则会影响控制精度。最后用螺栓锁紧支架。

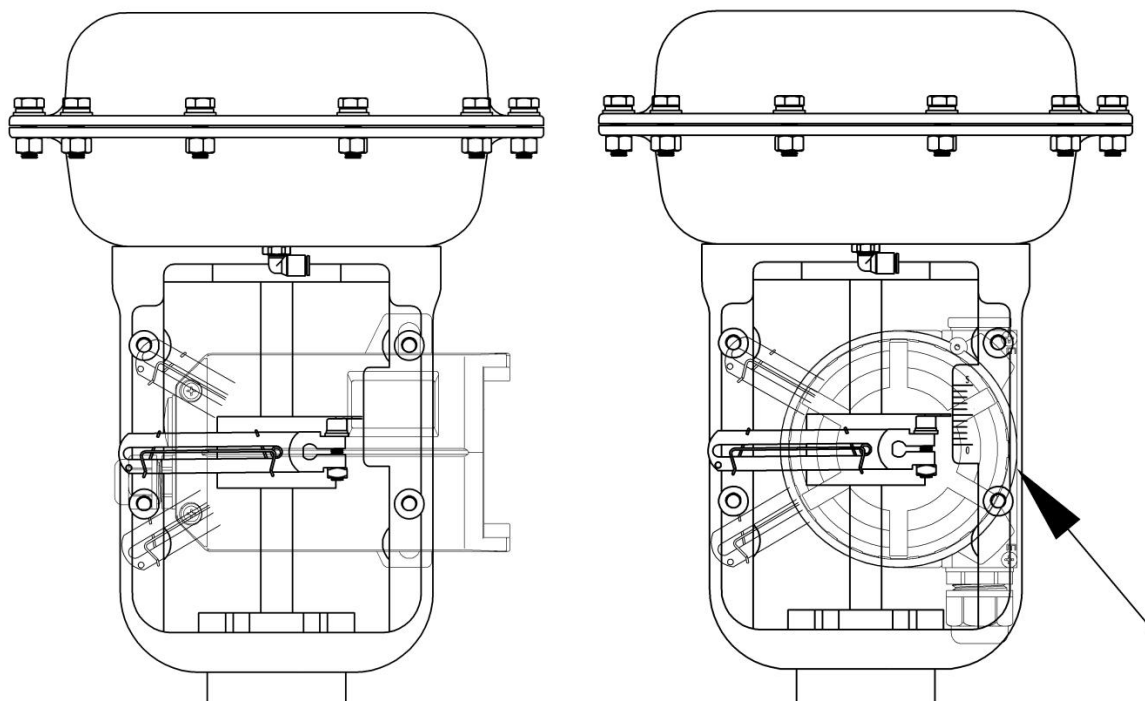
6. 整体示意图



图 23. 常规型直行程（反馈杆 A）



图 24. 远传型直行程（反馈杆 A）

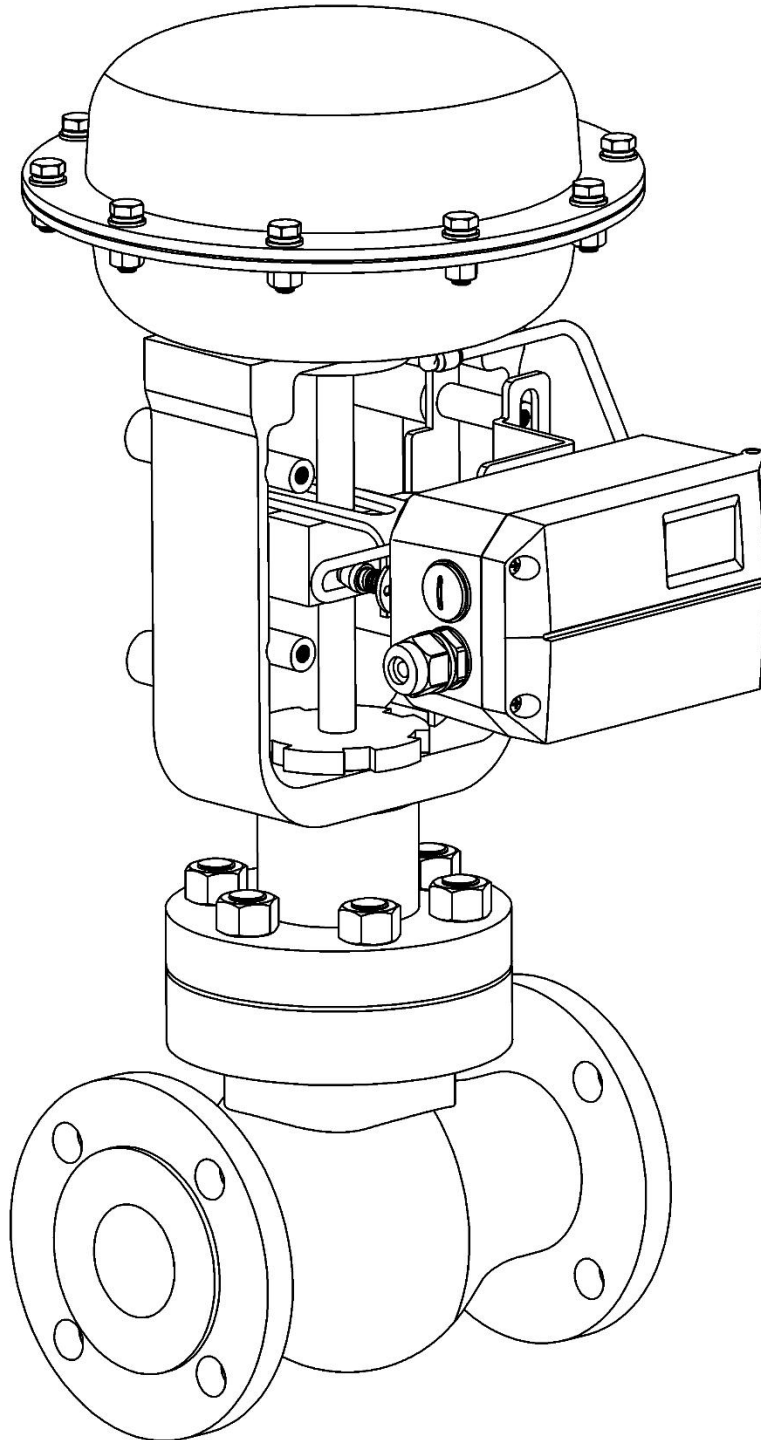

图 25. 常规型直行程（反馈杆 B）

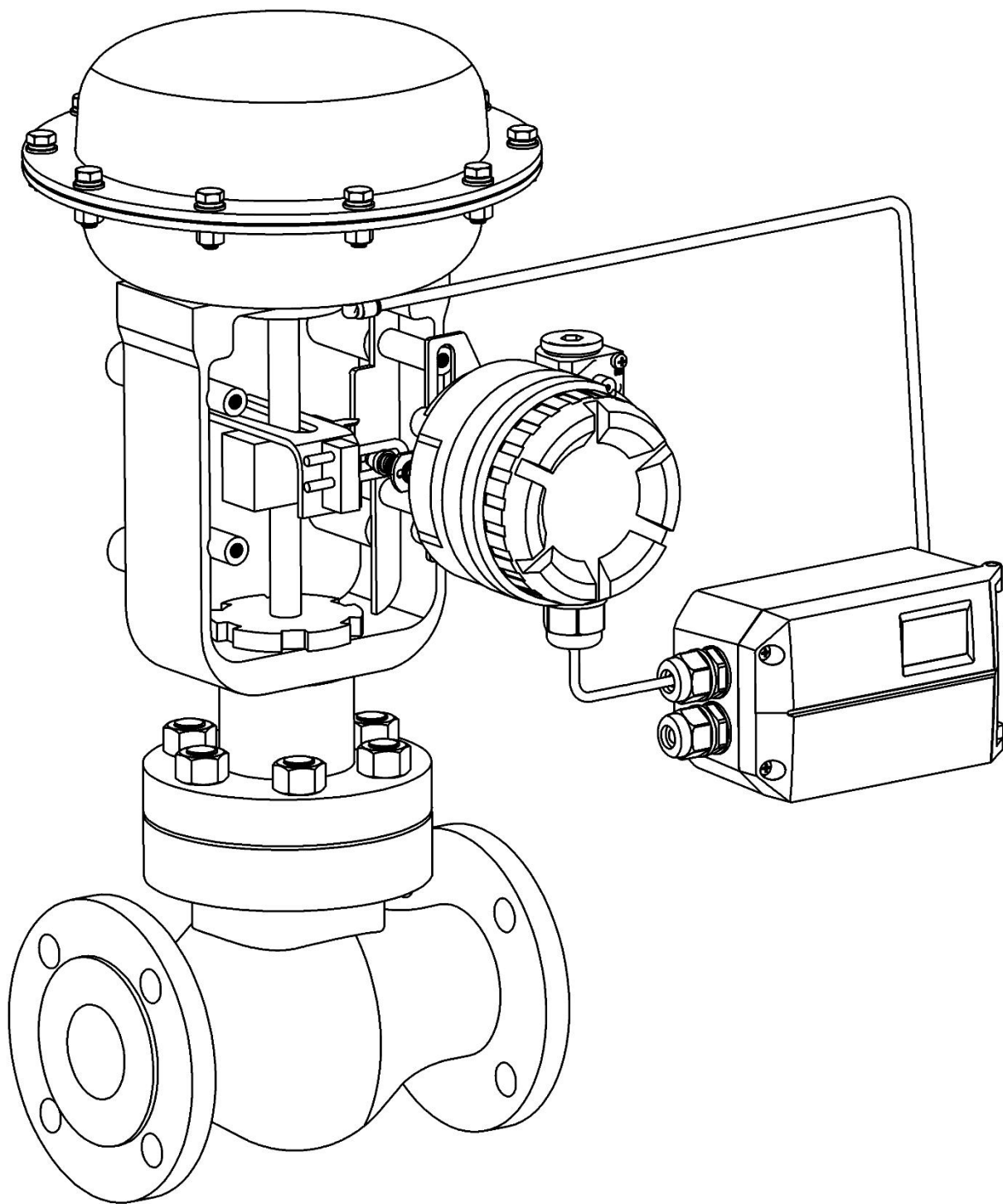

图 26. 远传型直行程（反馈杆 B）

7.2. 角行程（常规型或远传型）

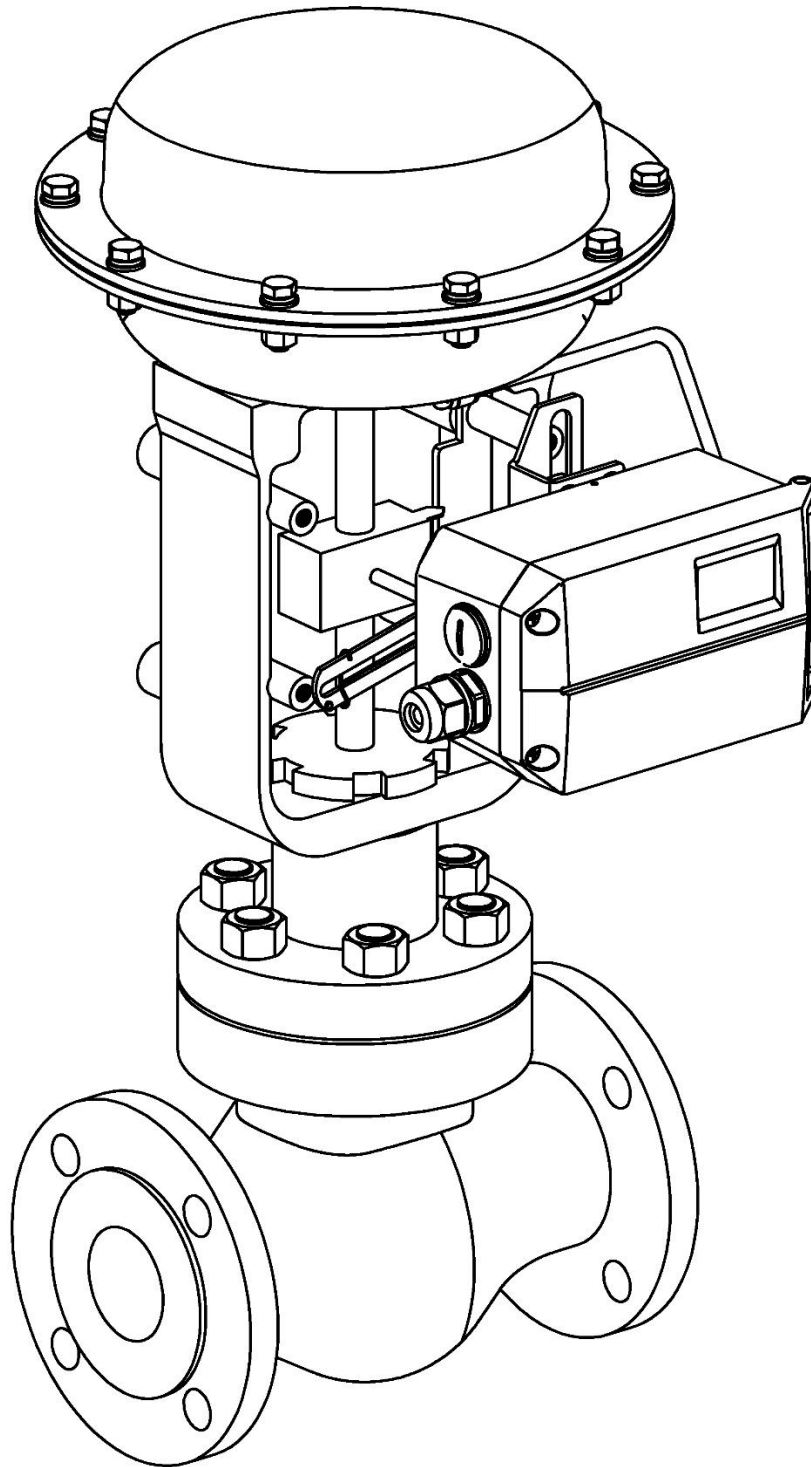
角行程执行机构安装组件			
序号	名称	数量	注意
①	适配器	1	安装在定位器主轴上
②	内六角紧定螺钉	2	M4×8，固定适配器于主轴上
③	角行程安装支架	1	可兼容不同规格的执行器
④	M6 平垫圈	4	保护接触表面
⑤	M6 弹簧垫圈	4	防止螺钉松动
⑥	M6 内六角螺钉	4	M6×10
⑦	M5 内六角螺钉	4	M5×8
⑧	M5 弹簧垫圈	4	防止螺钉松动
⑨	M5 平垫圈	4	保护接触表面

安装前注意事项：

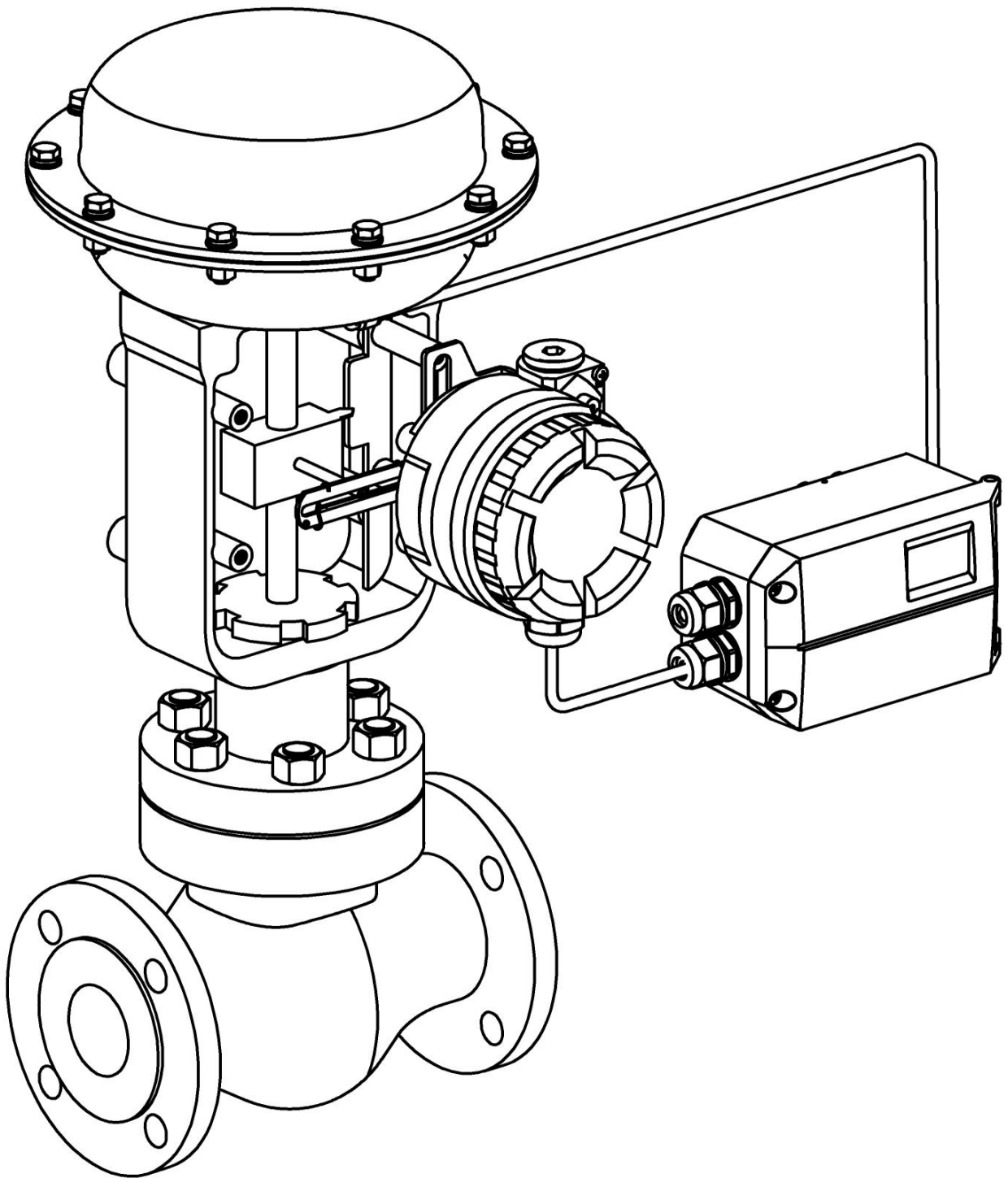
请先做好以下准备，安装步骤中以图 27 所示第一种情况为例进行配图。图 27 中标注了执行器转动轴在初始位置处的插槽方向和旋转方向。↓ 指示执行器气动接口位置。

- 将执行器转动轴调到初始位置。对于单作用执行器，将执行器气缸排空空气。对于双作用执行器，将内部一个气缸排空空气，一个气缸充满空气。注意转动轴在初始位置处的插槽方向。
- 确定执行器转动轴的旋转方向。对于单作用执行器，从初始位置开始对执行器气缸进气。对于双作用执行器，从初始位置开始，对排空空气的气缸进气，对充满空气的气缸排气。以此来判断转动轴的旋转方向。
- 将定位器反馈轴的指针旋转至对应图示位置，务必在转动标识范围内转动反馈轴。
- 将适配器以对应图示方向放置。



图 27. 四种情况安装匹配

- 注意远传型与常规型之间的区别，远传型的安装请参考常规型。

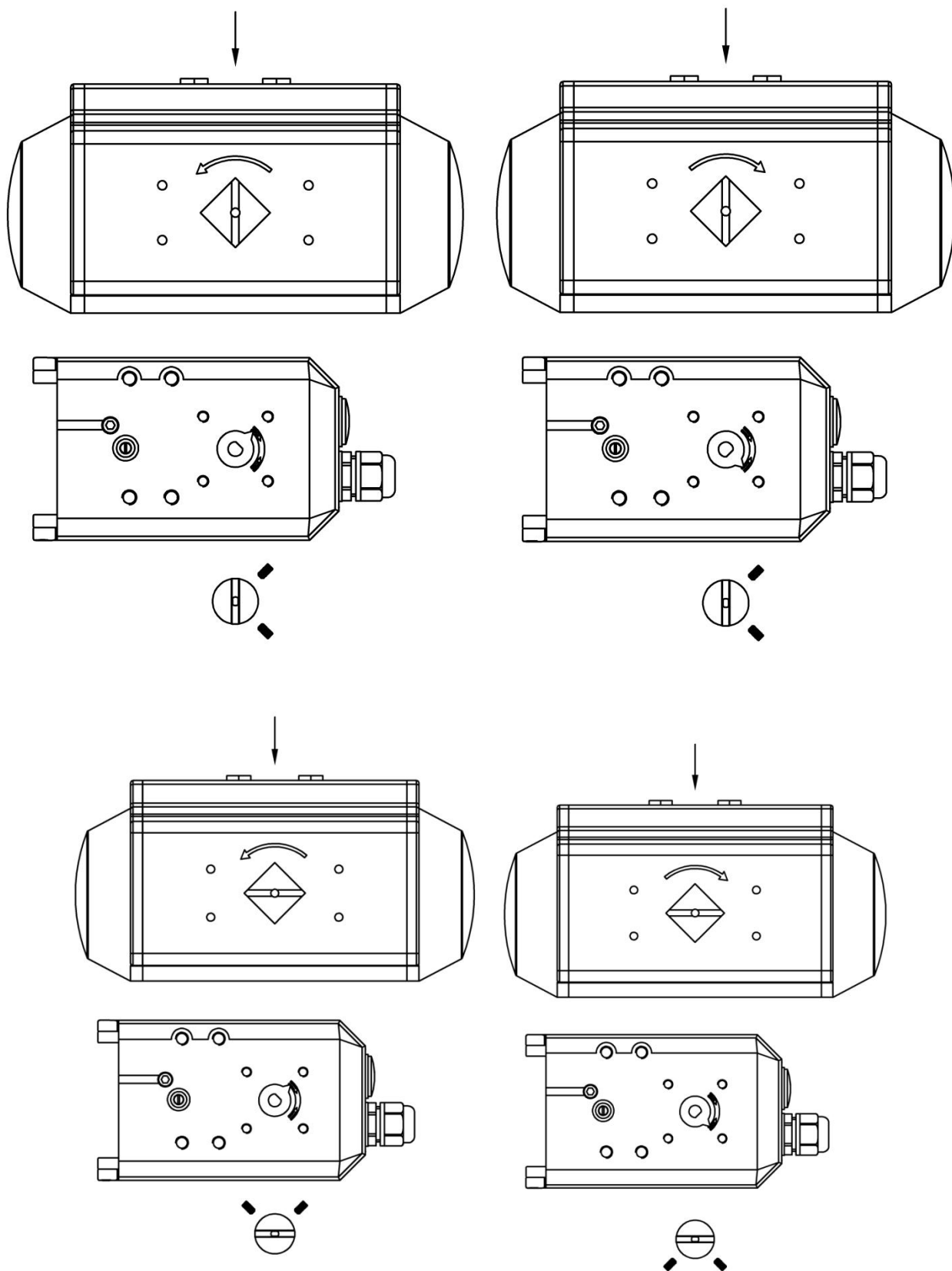

图 28. 远传型与常规型反馈轴指针对照

1. 确认定位器或远传型传感器反馈轴的初始位置（操作同 7.1 章节直行程安装）。
2. 把适配器安装在定位器或远传型传感器的反馈轴上。

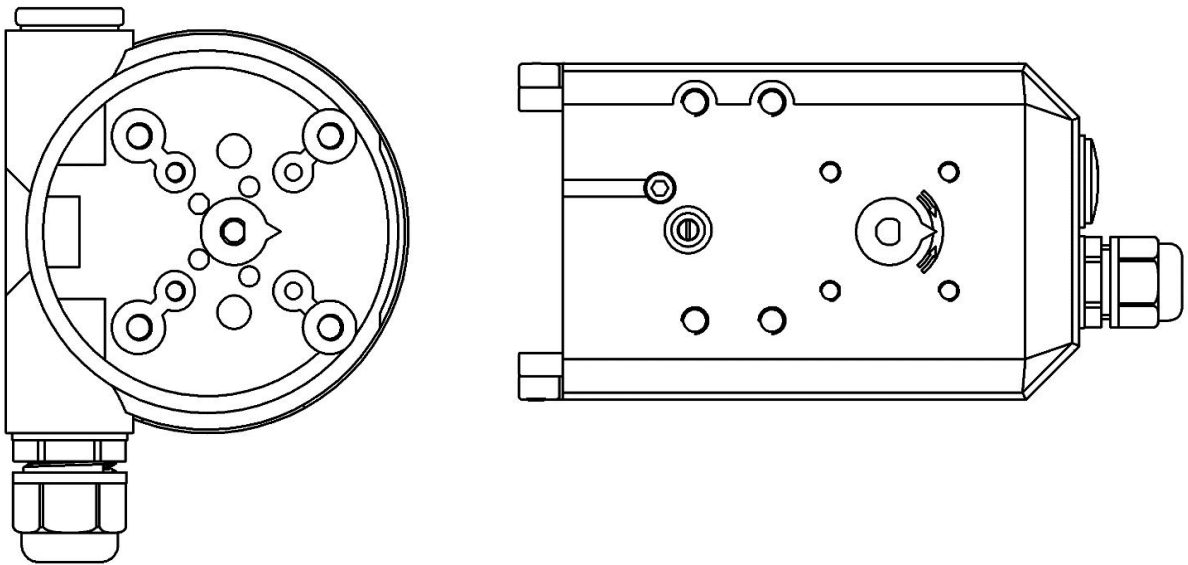

图 29. 适配器安装

把适配器按照准备时的摆放方向装到反馈轴上，并用紧定螺钉②将其固定；确保紧定螺钉之一锁紧在反馈轴的平坦一侧。

3. 把角行程安装支架安装到定位器或远传型传感器的底部。

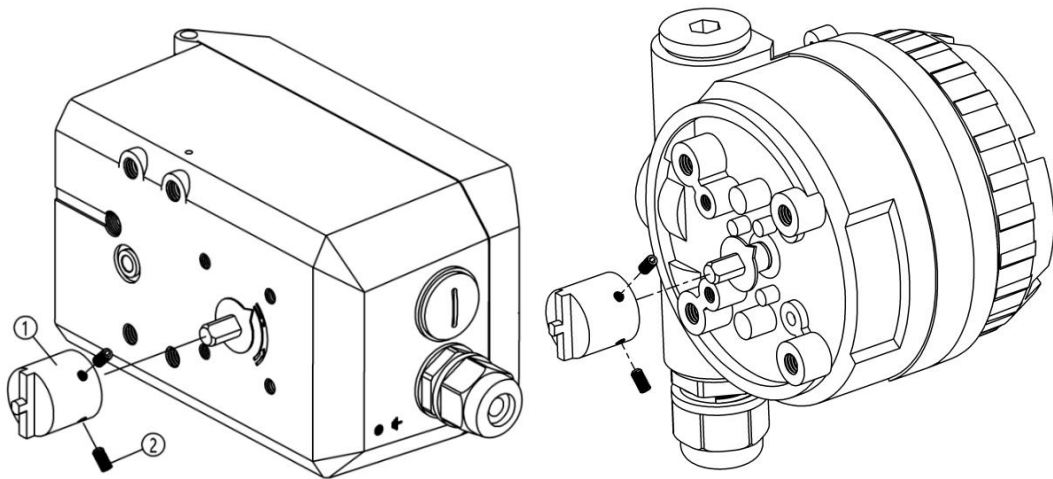

图 30. 角行程安装支架安装

4. 把角行程安装支架固定到执行器上。

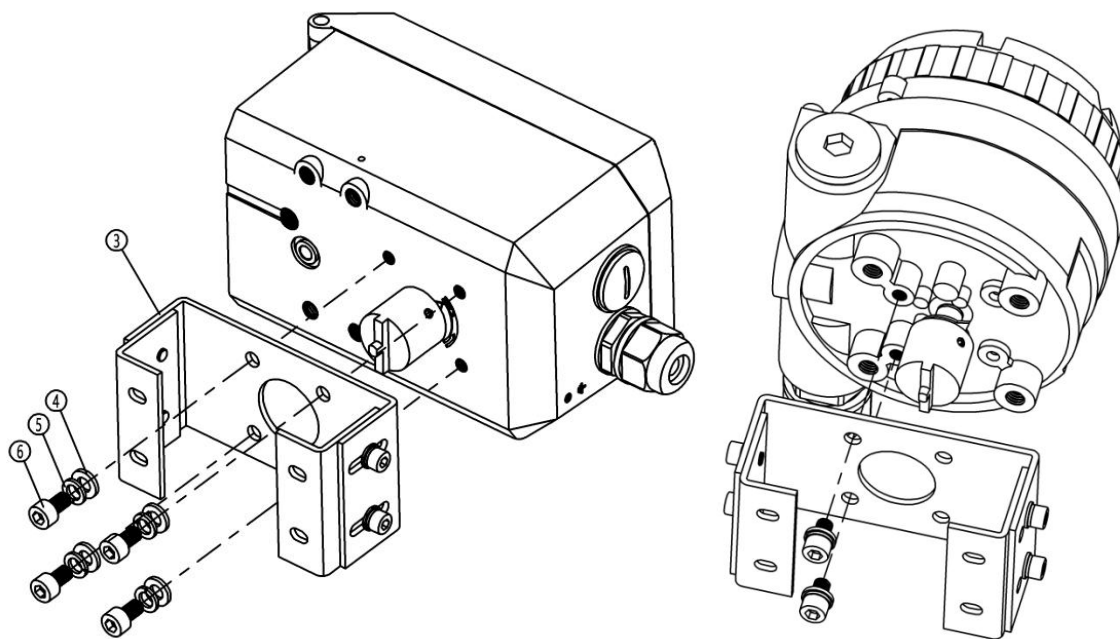

图 31. 与执行器安装

5. 整体示意图。



图 32. 常规型角行程

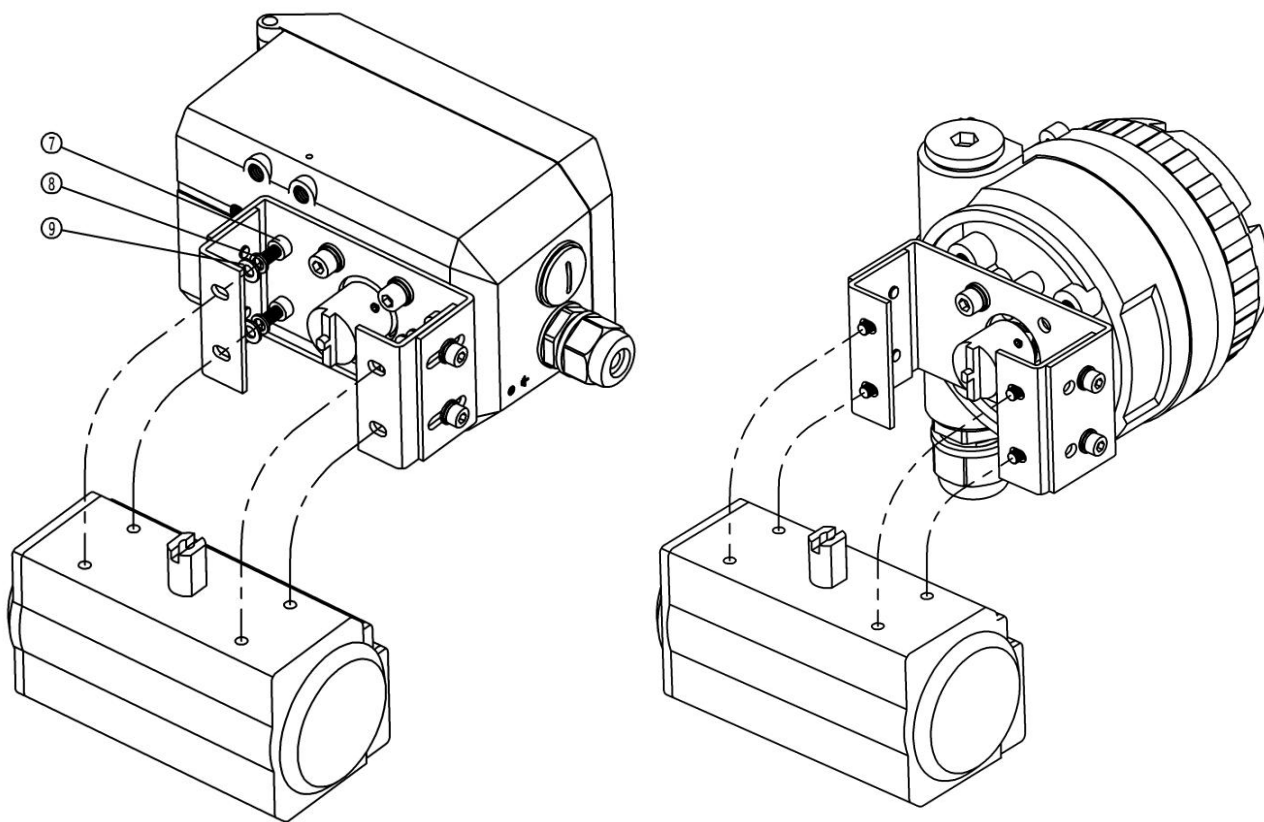

图 33. 远传型角行程

8. 操作

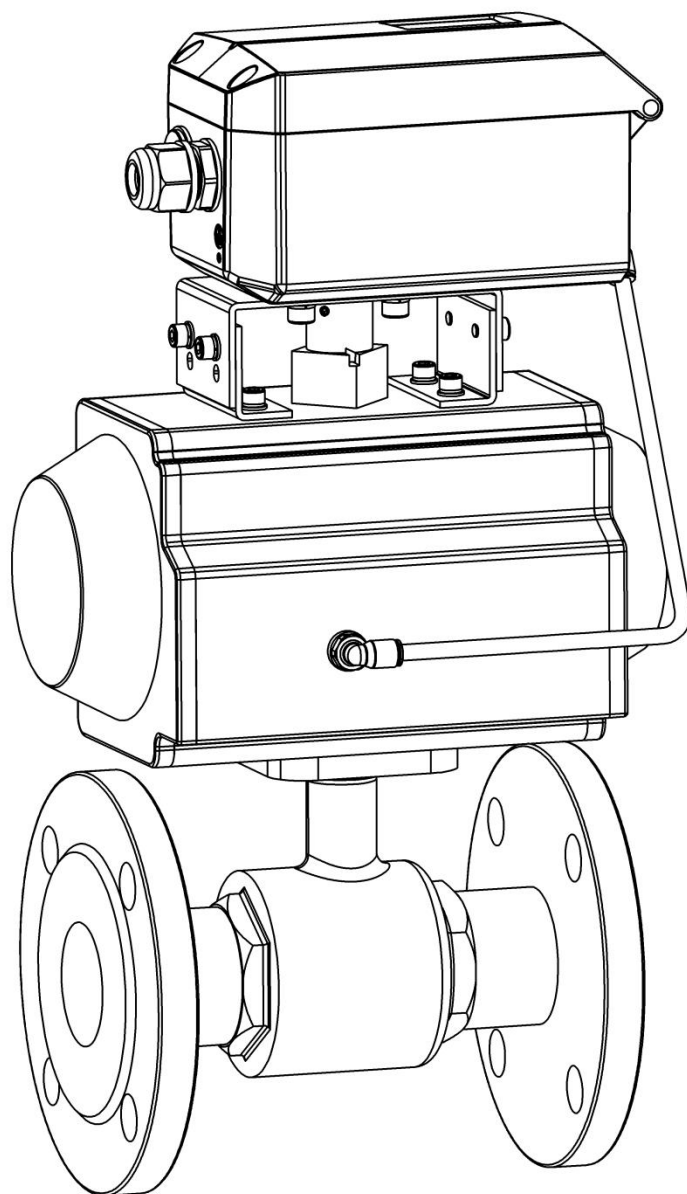

8.1. 界面描述

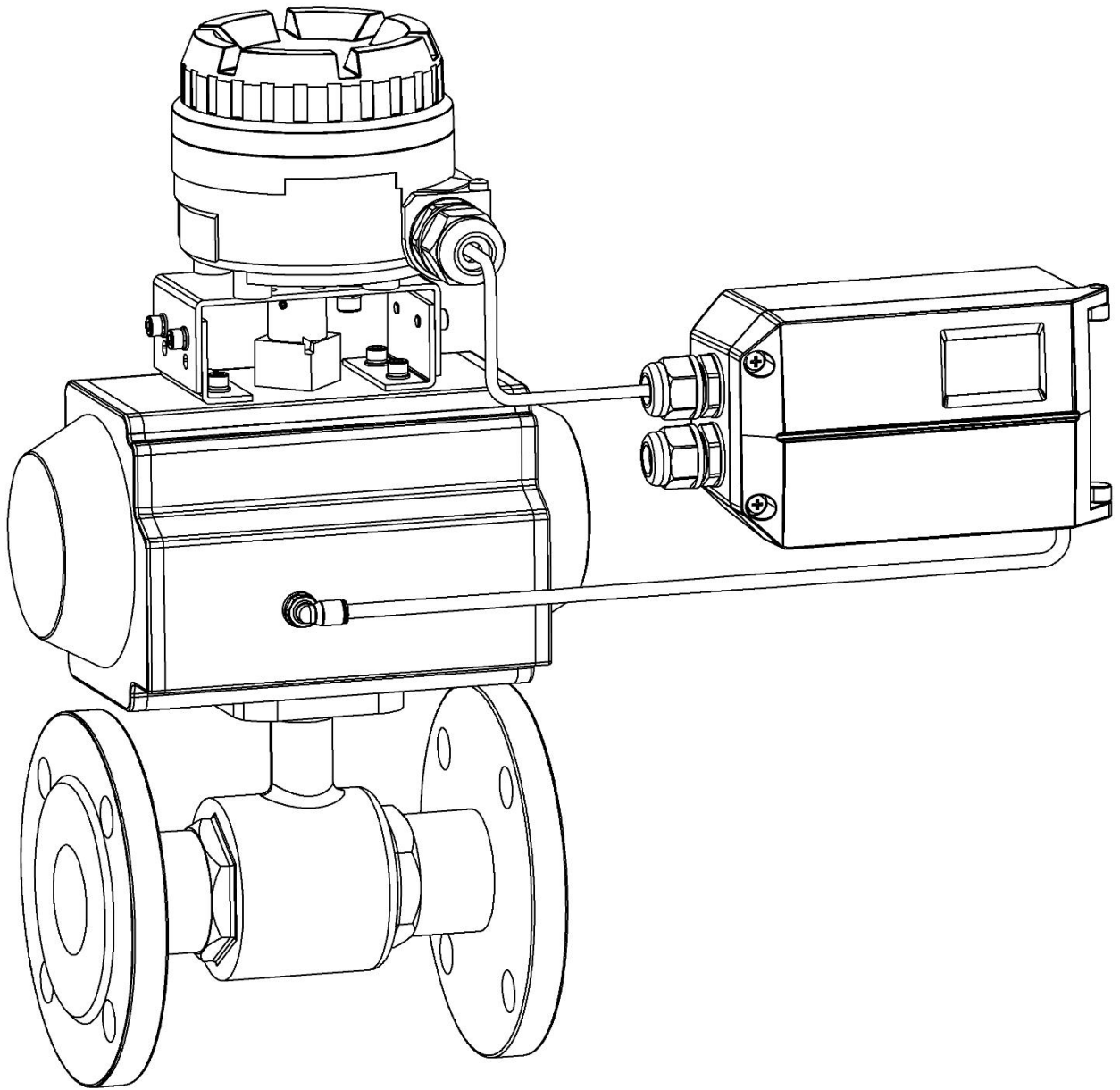

用户操作界面由一个 LCD 和 4 个按键组成。

LCD 显示说明

位置	描述
第一行	<ul style="list-style-type: none"> ● 初始界面（NOINI）或运行初始化功能时显示角度传感器百分比值。 ● 工作模式下显示阀位百分比值。 ● 菜单模式下显示参数值。
第二行	<ul style="list-style-type: none"> ● 未初始化状态下显示提示标志。 ● 工作模式下显示自动或手动模式。 ● 工作模式下设定百分比值。 ● 菜单模式下显示功能选项。 ● 初始化过程中显示初始化进程和错误提示。

按键操作说明

按键	操作说明
	<ul style="list-style-type: none"> ● 进入系统菜单。 ● 工作模式下手动模式切换。 ● 从系统菜单退出到主界面。 ● 从子菜单退出到上一级菜单。
	<ul style="list-style-type: none"> ● 初始界面（NOINI）下打开或关闭阀门。 ● 手动模式下减小阀位值。如果先按住此键，再按住键，阀位值快速减少。 ● 菜单模式下向下选择功能选项、参数或减小数值参数值。

	<ul style="list-style-type: none"> ● 初始界面（NOINI）下打开或关闭阀门。 ● 手动模式下增加阀位值。如果先按住此键，再按住键，阀位值快速增加。 ● 菜单模式下向上选择功能选项、参数或增加数值参数值。
	<ul style="list-style-type: none"> ● 菜单模式下进入子菜单、使能或确认参数修改。 ● 菜单模式下运行初始化或恢复出厂设置。 ● 初始界面（NOINI）或手自动模式界面运行初始化功能。

8.2. 主界面显示和操作

系统在没完成初始化功能前处于未初始化状态。显示标志为 NOINI，界面第一行显示传感器百分比值。如图 34 所示。







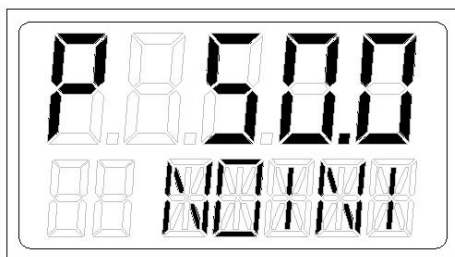

图 34. 未初始化状态界面

在此状态下，操作  键可打开或关闭阀门。将阀门全开和全闭，观察界面上显示传感器百分比值。确保在整个阀门行程范围内，传感器百分比最小值 $\geq 5\%$ ，传感器百分比最大值 $\leq 95\%$ 。否则，需要重新调整安装位置使直行程反馈杆或角行程适配器在有效范围内动作。另外，要求传感器最小最大百分比差值大于 16%。

如果要快捷操作自动初始化（INITA）功能，则在初始界面（NOINI）或手自动模式界面长按  键 3 秒左右开始运行自动初始化。初始化运行过程中按  键可退出。退出后，如果之前初始化完成过，则进入手动模式界面，否则进入初始界面（NOINI）。初始化完成后，按  键退出。退出后，系统进入手动模式界面。

系统工作模式分为自动模式和手动模式。

在自动模式下，系统采集外部 4-20mA 设定信号自动调节阀门开度。

在手动模式下，通过手动操作 \downarrow \uparrow 键来调节阀门开度。

主界面上第一行显示阀位百分比值，第二行显示设定百分比值。其中第二行设定百分比显示值最后一个数值为一位小数。符号 **A** 表示自动模式，符号 **M** 表示手动模式。可通过按键 \square 切换自动模式和手动模式。键按住后松开时间小于进入菜单操作的时间则进行手自动模式切换，否则进入菜单。如图 35 所示



图 35. 系统工作模式界面

当 4-20mA 设定信号 ≤ 3.5 mA 时，系统认为信号错误。主界面第二行的设定百分比显示值位置处显示 **ERR** 标志。此时，阀位状态为产品选型中断电状态。

8.3. 菜单和功能

8.3.1. 菜单显示和操作

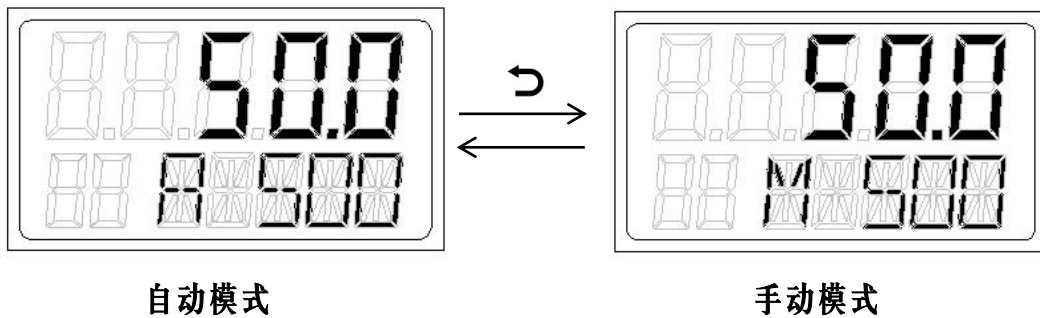
长按 \square 键 3 秒左右，系统进入菜单。菜单界面显示内容描述如图 36 所示。在菜单界面，按 \square 键，系统从菜单界面退出到手动模式工作界面。带 HART 功能的定位器在菜单界面下无法通过 HART 通讯来修改参数或运行初始化操作。



图 36. 菜单界面

8.3.2. 功能描述和操作

8.3.2.1. TYPE

选择执行机构类型。

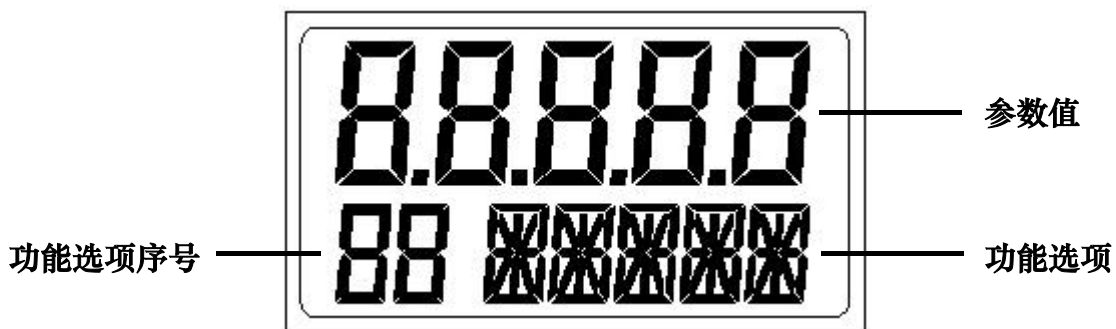
设置参数选项

选项	描述
Lin	安装反馈杆 A 的直行程执行机构。
Turn	角行程执行机构。
FLin	安装反馈杆 B 的直行程执行机构。

菜单界面选择此功能，按 键开启参数设置，参数闪烁显示。按 键设置参数。按 键确认修改。

8.3.2.2. INITA

该功能为自动初始化。该功能自动检测动作方向，阀门实际物理行程，控制参数。

菜单界面选择此功能，长按 键 3 秒左右开始运行，LCD 左下角出现滚动标志，第一行显示传感器百分比值，第二行显示运行步骤。自动初始化完成后，LCD 上显示 FINSH。

自动初始化过程中由于某些原因，系统会在功能选项栏显示错误提示。并中断初始化。错误提示说明及处理方法详见 8.3.3 章节。

8.3.2.3. INITM

该功能为手动初始化。适用于用户手动来确定阀门行程。

该功能先手动标定阀门行程，再自动检测动作方向，控制参数。操作流程如下：

1. 菜单界面选择此功能，长按 键 3 秒左右开始运行，LCD 左下角出现滚动标志，第一行显示传感器百分比值，第二行显示显示 END 1。
2. LCD 上显示 END 1 后，操作 键将阀位移动至手动标定的行程端点 1，按 键确

认，LCD上显示END 2。再次操作 \downarrow \uparrow 键将阀位移动至手动标定的行程端点2，按 \odot 键确认。

3. END 2确认后，如果LCD上没有错误提示，则系统自动从初始化第1步开始执行，并跳过第2步行程检测。

手动初始化完成后，LCD上显示FINSH。

手动初始化过程中由于某些原因，系统会在功能选项栏显示错误提示。并中断初始化。错误提示说明及处理方法详见8.3.3章节。

8.3.2.4. CAL

4-20mA 设定信号的校正。当设定值与信号源的输出值有较大偏差时，可通过此功能对设定信号做校正。

CAL 的子功能选项 4 mA 和 20 mA 分别校正 4-20mA 设定信号最小最大值。

菜单中选择此功能，按 \odot 键进入子功能选择操作，按 \downarrow \uparrow 键选择子功能选项 4 mA 或 20 mA，按 \odot 键开启参数设置，LCD 上闪烁显示实际设定信号的 AD 值（将设定信号用数字来量化，范围为 0-4095 的数值）。对于选项 4 mA，将前端设定信号设置为 4 mA 信号；对于选项 20 mA，将前端设定信号设置为 20 mA 信号。例如，前端设定信号设置为 4 mA 时，LCD 上闪烁显示数值为 650，待 LCD 上 AD 值稳定后按 \odot 键确认，系统会记录当前 AD 值 (650) 并显示在 LCD 上；例如，前端设定信号设置为 20 mA 时，LCD 上闪烁显示数值为 3270，待 LCD 上 AD 值稳定后按 \odot 键确认，系统会记录当前 AD 值 (3270) 并显示在 LCD 上。选项 4 mA 和选项 20 mA 都操作完成后即完成 4-20mA 设定信号的校正。

例如现场 4-20mA 信号设定为 50% (12mA)，而定位器实际采集的信号值 52% (12.32 mA)。说明设定信号和定位器实际采集的信号存在偏差。此时通过如上所述的菜单操作来校正定位器采集的设定值，使其与系统前端 4-20mA 信号设定值对应。

8.3.2.5. SDIR

此功能用来设置 4-20mA 设定信号与设定值之间的对应关系。

菜单界面选择此功能，按 \odot 键开启参数设置，参数闪烁显示。按 ∇ \blacktriangle 键设置参数。按 \odot 键确认修改。

设置参数选项

选项	描述
riSE	4 mA \rightarrow 0%，20 mA \rightarrow 100%。
FALL	4 mA \rightarrow 100%，20 mA \rightarrow 0%。



图 37.SDIR

8.3.2.6. CHAR

特性曲线是阀位设定值与阀门行程的转换关系。

在实际控制系统中，通常要求使被控量具有特定的控制特性（比如线性）。用户可以选择和设置相应的特性曲线来达到控制要求。

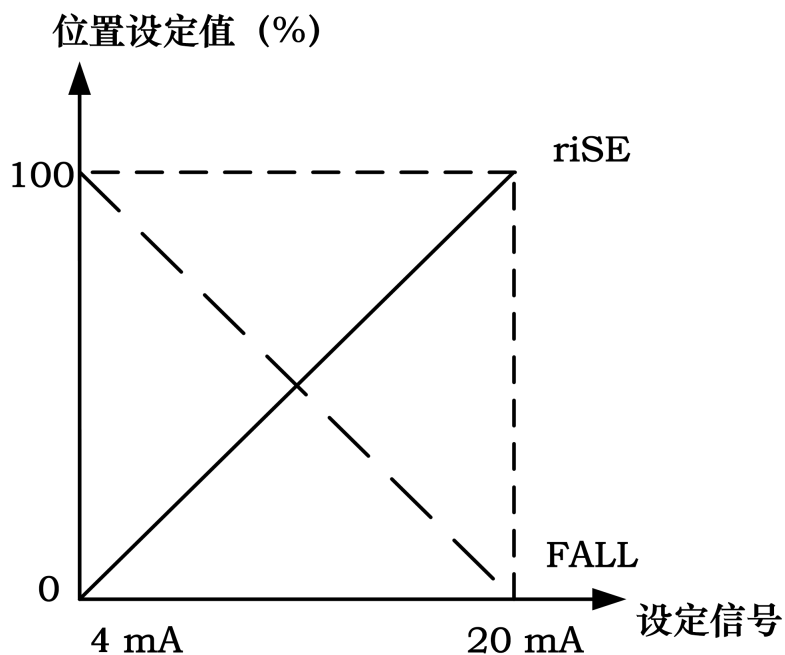
菜单界面选择此功能，按 \odot 键开启参数设置，参数闪烁显示。按 ∇ \blacktriangle 键设置参数。按 \odot 键确认修改。

特性曲线参数选项

选项	描述
Lin	位置设定值与阀门行程为 1:1 转换关系。
1-25	位置设定值与阀门行程为 1:25 等百分比转换关系。
1-33	位置设定值与阀门行程为 1:33 等百分比转换关系。
1-50	位置设定值与阀门行程为 1:50 等百分比转换关系。
n1-25	位置设定值与阀门行程为 1:25 反等百分比转换关系。
n1-33	位置设定值与阀门行程为 1:33 反等百分比转换关系。
n1-50	位置设定值与阀门行程为 1:50 反等百分比转换关系。
FrEE	用户自由定义位置设定值与阀门行程的转换关系。将 0-100% 的设定值范围等间隔分为 21 个设定点。每个点上都可设置行程范围为 0-100% 的值。可在 FR 0 , FR 5 , ..., FR 100 选项中设置数值。



图 38.CHAR

8.3.2.7. FREE

设置 CHAR 功能选项中 FrEE 特性曲线的数值。

FREE 的子功能选项为 FR 0, FR 5, ..., FR100, 共 21 个设定点。

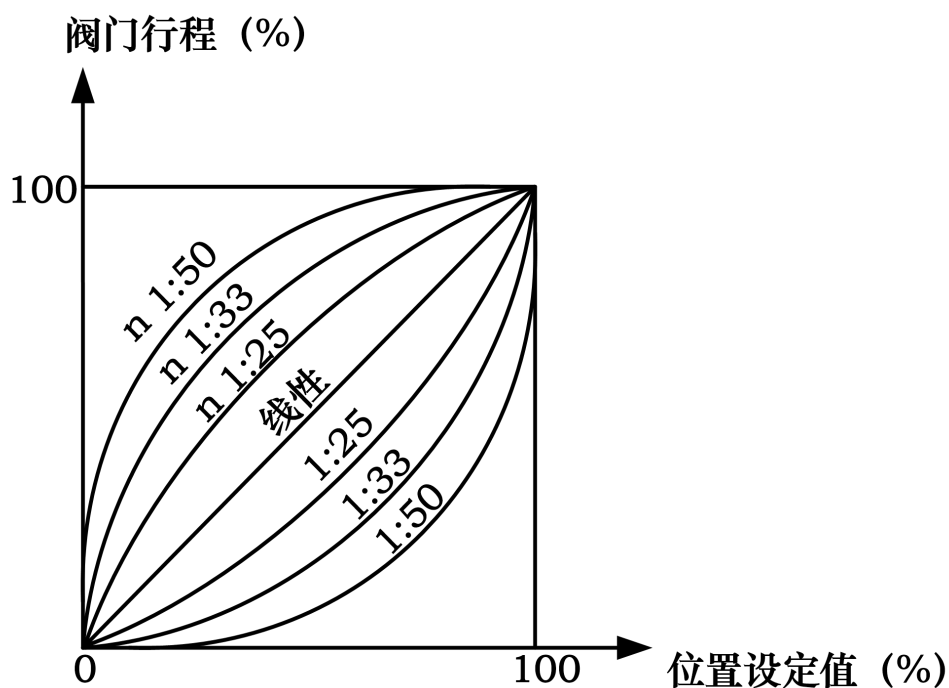
菜单中选择此功能, 按 \odot 键进入子功能选择操作, 按 $\blacktriangledown/\blacktriangle$ 键选择设定点, 按 \odot 键开启参数设置, 参数闪烁显示。按 $\blacktriangledown/\blacktriangle$ 键设置参数, 持续按 \blacktriangledown 键或 \blacktriangle 键可快速修改参数。按 \odot 键确认修改。



图 39.FREE

8.3.2.8. DB

定位器死区设置。

阀位值与阀位设定值之间的差值在死区设置范围内时, 系统认为调节到位而不做位置调

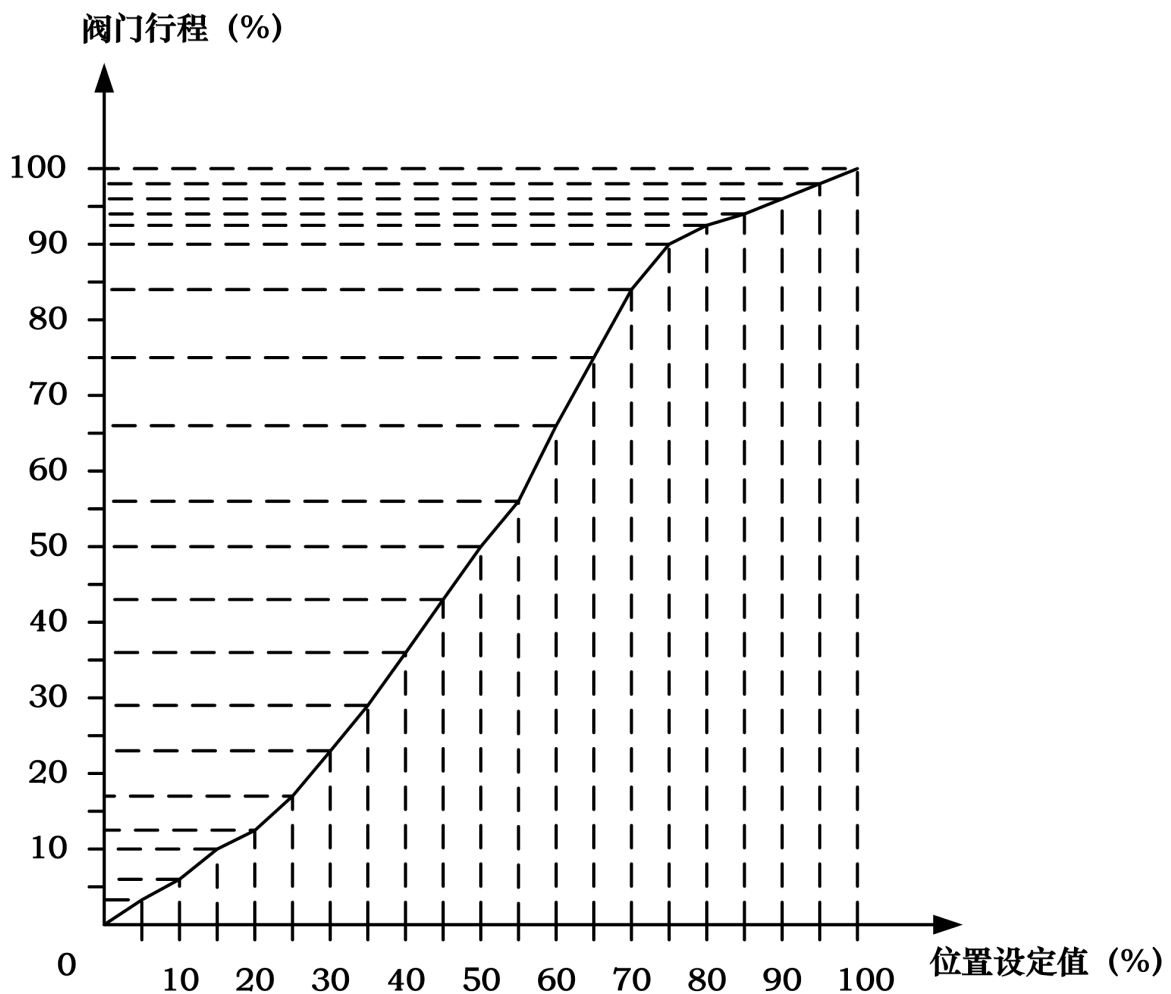
节动作。

例如，阀位设定值为 50%，死区值为 1%。则实际阀位在 $50\pm 1\%$ 范围内不做调节动作。如果实际阀位不在 $50\pm 1\%$ 范围内，则驱动压电模块调节阀位，最终使阀位处于 $50\pm 1\%$ 范围内。

如果阀位震荡，可将死区调大抑制震荡。死区越小，控制精度就越高。

菜单中选择此功能，按 \odot 键开启参数设置，参数闪烁显示。按 $\blacktriangledown\blacktriangle$ 键设置参数，持续按 \blacktriangledown 键或 \blacktriangle 键可快速修改参数。按 \odot 键确认修改。

8.3.2.9. LIM

此功能用于限制阀门在物理行程范围内的调节范围。

LIM 的子功能选项 L MIN 和 L MAX 分别设置限制行程的最小最大值。

菜单中选择此功能，按 \odot 键进入子功能选择操作，按 $\blacktriangledown\blacktriangle$ 键选择子功能选项 L MIN 或 L MAX，按 \odot 键开启参数设置，参数闪烁显示。按 $\blacktriangledown\blacktriangle$ 键设置参数，持续按 \blacktriangledown 键或 \blacktriangle 键可快速修改参数。按 \odot 键确认修改。



图 40.LIM

8.3.2.10.YDIR

此功能用于设置位置显示和位置反馈信号的动作方向。

菜单界面选择此功能，按 键开启参数设置，参数闪烁显示。按 键设置参数。
按 键确认修改。

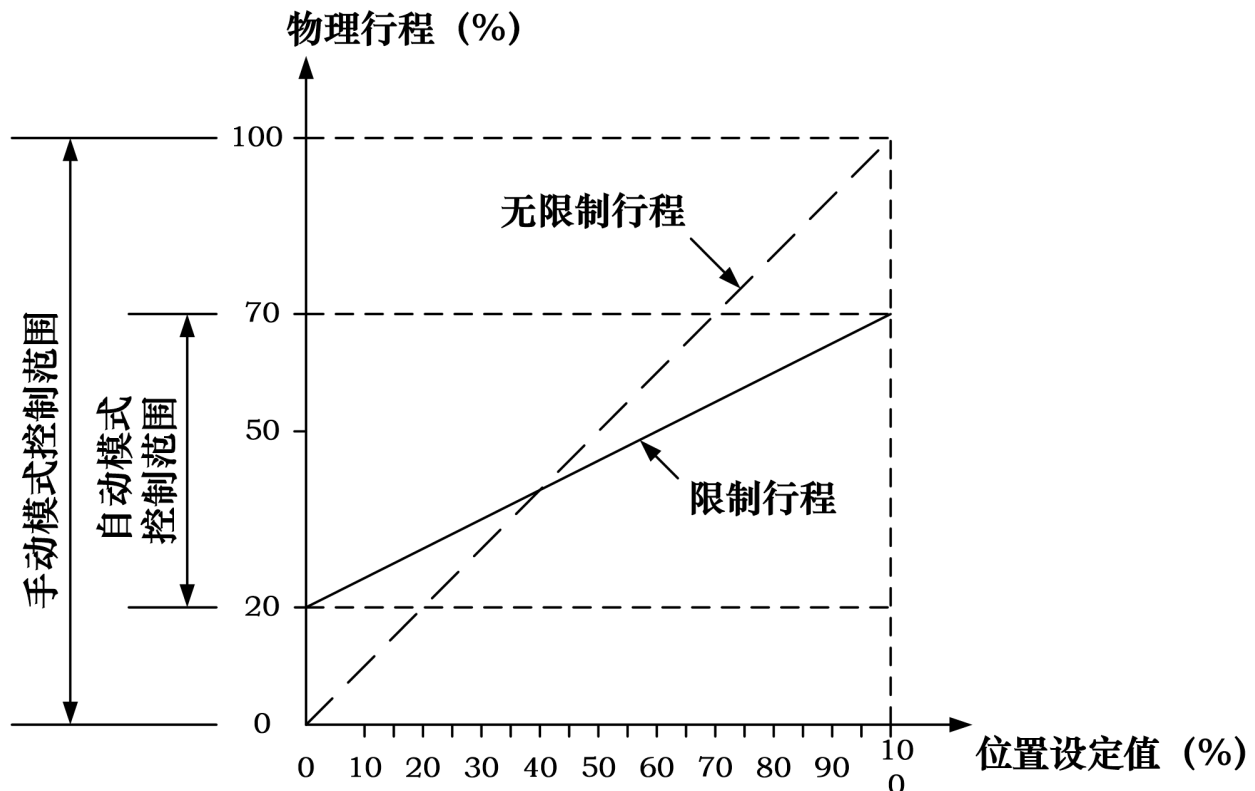
设置参数选项

选项	描述
riSE	位置显示以及位置反馈信号值与定位器检测的行程相对应。
FALL	位置显示以及位置反馈信号值与定位器检测的行程相反。

8.3.2.11.CUT

此功能用于定位器在自动模式下使阀门完全关闭或完全打开。当紧闭功能使能后，主界面左下角显示 CU 标志。

CUT 的子功能选项 C MIN 和 C MAX 分别设置紧闭最小最大值。

菜单中选择此功能，按 键进入子功能选择操作，按 键选择子功能选项 C MIN 或 C MAX，按 键开启参数设置，参数闪烁显示。按 键设置参数，持续按 键或 键可快速修改参数。按 键确认修改。

当 C MIN 为 0 时，完全关闭不起作用。当 C MAX 为 100 时，完全打开不起作用。

在阀门定位状态，当设定值 \leq C MIN 时，阀门完全关闭；当设定值 \geq C MAX 时，阀门完全打开。

在完全关闭状态，当设定值 $>$ C MIN + 1% 时，阀门脱离完全关闭状态。

在完全打开状态，当设定值 $<$ C MAX - 1% 时，阀门脱离完全打开状态。



图 41.CUT

8.3.2.12.POS

此功能用于设置位置显示和反馈信号输出的标准。

菜单界面选择此功能，按 键开启参数设置，参数闪烁显示。按 键设置参数。

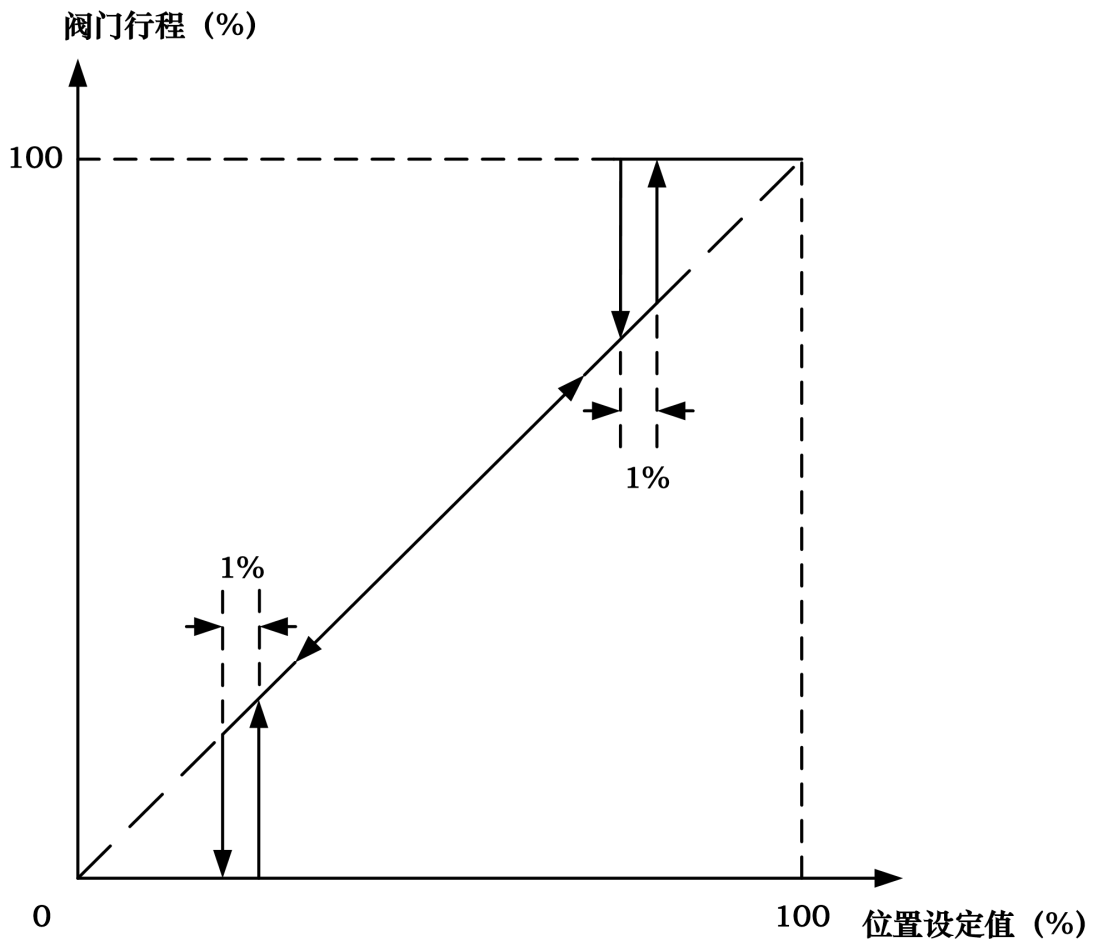
按 键确认修改。

设置参数选项

选项	描述
FS	位置显示和反馈信号输出对应机械行程 0-100%。设定值以实际阀位设定值显示。不受 L MIN 和 L MAX 参数影响。
LS	位置显示和反馈信号输出采用 0-100% 的形式来表示 L MIN 和 L MAX 参数之间的范围。设定值以此标准显示。



图 42. 示例: POS = FS, L MIN = 20%, L MAX = 90%





图 43. 示例: POS = LS, L MIN = 20%, L MAX = 90%

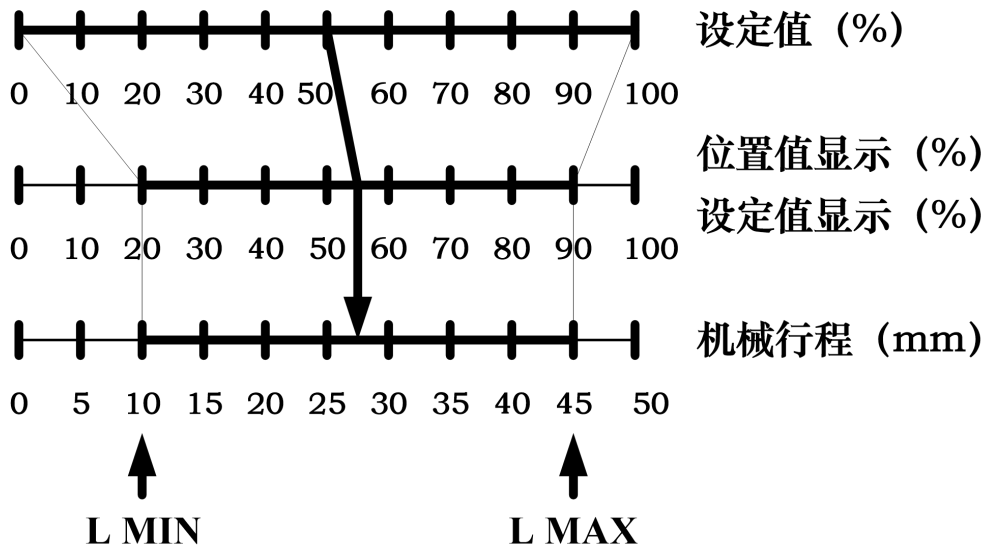

8.3.2.13.FACT

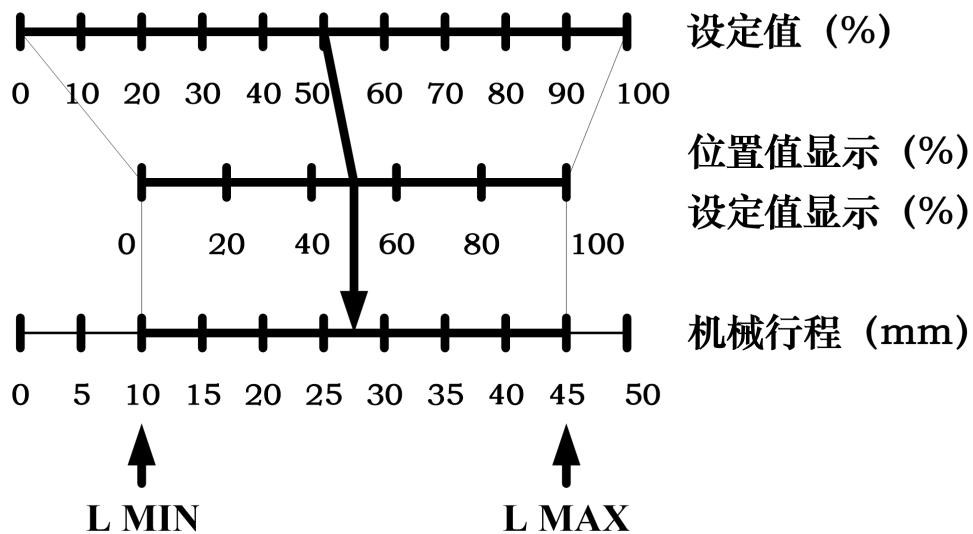
将定位器恢复到出厂设置。

菜单中选择此功能，长按  键 3 秒左右恢复出厂设置。恢复出厂设置后，系统处于未初始化状态，LCD 显示 FINSH。

8.3.2.14.WP

此功能为参数写保护功能。参数 **oFF** 为写保护关闭，参数 **on** 为写保护开启。

菜单界面选择此功能，按  键开启参数设置，参数闪烁显示。按  键设置参数。

按  键确认修改。

当写保护开启后，菜单选项 1-13 无法操作。

8.3.2.15.ACT



作用方式选择。厂家内部使用。无特殊情况不建议用户操作此选项。

8.3.2.16.REF

直行程反馈杆参考点标定。厂家内部使用。无特殊情况不建议用户操作此选项。

8.3.3. 初始化过程错误提示

提示标志	提示说明	推测原因	处理方法
ERR 1	执行器动作错误	<ul style="list-style-type: none"> ● 无气源压力或气源压力不够。 ● 定位器或阀门存在漏气。 	<ul style="list-style-type: none"> ● 检查气源和气源压力，确保供气正常。 ● 消除漏气问题。
ERR 2	反馈摆杆或转动轴的转动角度错误。	<ul style="list-style-type: none"> ● 定位器安装不到位。致使执行器反馈摆杆或转动轴的转动角度不满足安装要求。 ● 手动初始化时，手动标定的 END 1 和 END 2 	<ul style="list-style-type: none"> ● 在初始界面（NOINI）下，通过 LCD 上显示的角度传感器百分比值调整安装位置，使角度传感器转动最小最大百分比差值大于 16%。 ● 如果是在手动初始化操作

		两个行程端点的差值不满足要求。	过程，则通过操作   键重新标定 END 1 和 END 2,使两个行程端点间的传感器百分比差值大于 16%。
ERR 3	传感器行程最小值错误。	定位器安装不到位。	在初始界面（NOINI）下，通过 LCD 上显示的传感器百分比调整安装位置。使传感器百分比最小值 $\geq 2\%$ 。
ERR 4	传感器行程最大值错误。	定位器安装不到位。	在初始界面（NOINI）下，通过 LCD 上显示的传感器百分比调整安装位置。使传感器百分比最大值 $\leq 98\%$ 。

8.3.4. 菜单选项或功能无法访问提示

当设置菜单选项参数或运行初始化时可能会出现如下标志来提示无法访问。具体说明见下表。

提示标志	提示说明
P1	写保护开启。
P2	直行程反馈杆参考点未标定，无法对直行程执行机构进行初始化操作。

8.3.5. 菜单功能选项汇总说明

选项	功能	参数值	出厂设置
1 TYPE	执行机构类型设置	Lin Turn FLin	Lin

2 INITA	自动初始化		
3 INITM	手动初始化		
4 CAL→4 mA	4mA 设定信号校正	当前信号 AD 值	765
4 CAL→20 mA	20mA 设定信号校正	当前信号 AD 值	3823
5 SDIR	设定信号方向设置	riSE FALL	riSE
6 CHAR	特性曲线选择	Lin 1:25 1:33 1:50 n1:25 n1:33 n1:50 FrEE	Lin
7 FREE→FR 0, FR 5...FR100	自定义参数设置	0.0% – 100.0%	0.0% 5.0% etc. to 100.0%
8 DB	死区设置	0.2 – 10.0%	1.0%
9 LIM→L MIN	行程限制功能最小值设置	0.0% – 100.0%	0.0%
9 LIM→L MAX	行程限制功能最大值设置	0.0% – 100.0%	100.0%
10 YDIR	位置显示和反馈方向设置	riSE FALL	riSE
11 CUT→C MIN	紧闭功能最小值设置	0.0% – 100.0%	1.0%
11 CUT→C MAX	紧闭功能最大值设置	0.0% – 100.0%	100.0%
12 POS	位置显示和反馈信号输出 标准设置	FS LS	FS
13 FACT	恢复出厂设置		
14 WP	写保护	oFF on	oFF
15 ACT	作用方式选择		
16 REF	直行程反馈杆参考点标定		

8.4. 反馈信号

定位器可选配输出 4-20 mA 的反馈信号。反馈信号用来指示阀门位置百分比。

进入菜单后，反馈信号输出将停止更新。

8.5. 流量调节

1. 取下电路板保护盖



图 44. 拆除电路板保护盖

注意：请在设备断电情况下拆装电路板保护盖。

2. 调整节流杆位置

- 对于小型执行机构而言，节流杆可减少空气输出，增加定位稳定性。为此，可使用节流杆 Y1①和 Y2②。
- 使用一字螺丝刀顺时针转动节流杆，可减少空气输出直至最终切断输出。

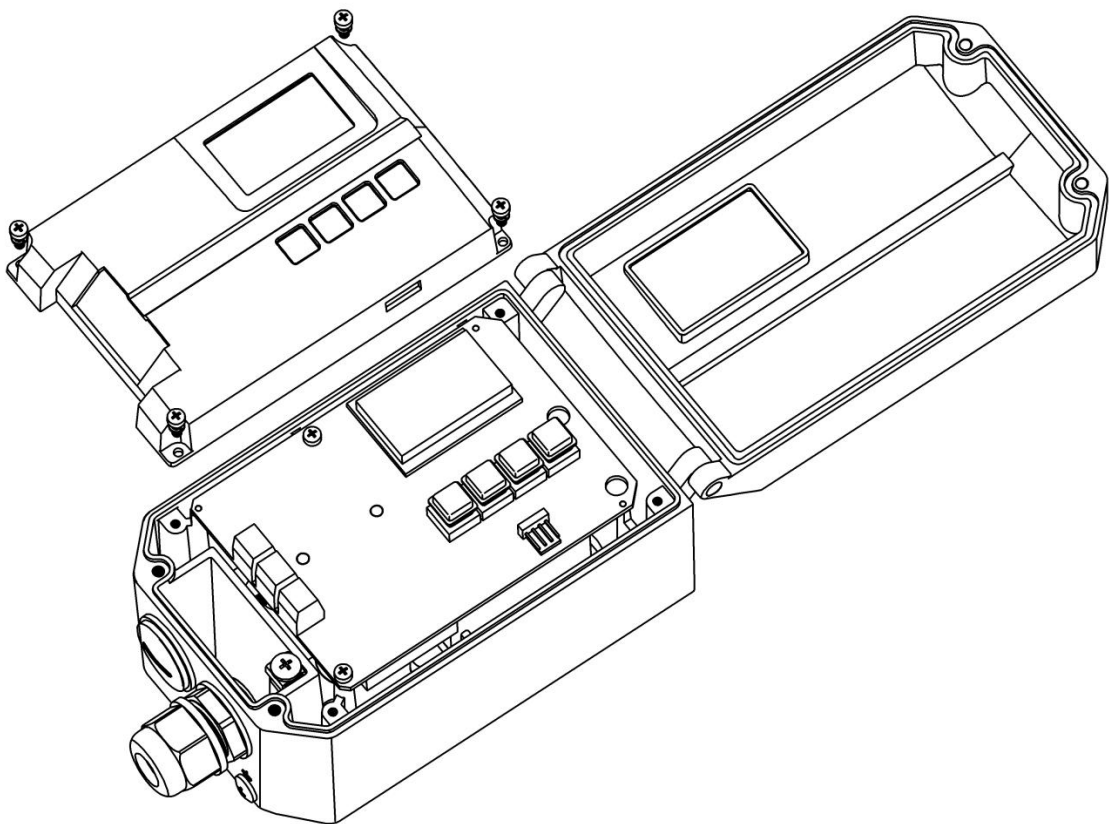
- 设置节流杆时，建议先将其关闭，然后再缓慢打开。
- 双作用阀的情况下，确保两个节流杆的设置位置相仿。



图 45. 流量调节

- ① 节流杆 Y1
- ② 节流杆 Y2，仅适用于双作用执行机构版本。

9. 故障检修

内容	推测原因	处理方法
LCD 无显示	电气接口连接错误	请确认定位器的电气连接
	电流源没有电流输出	确认输入电流源是否有电流输出
	使用超出规格范围的输入电流源	请使用正常的输入电流源
	其他	请向本公司询问
OUT1 或 OUT2 口无空气输出 (完全没有动作)	供气压力不正常	请确认供气压力减压阀的设定
	没有输入电流	请正确输入电流 (4-20mA DC)
	配管漏气	请确认配管及管头，阻止泄露
	其他	请向本公司询问

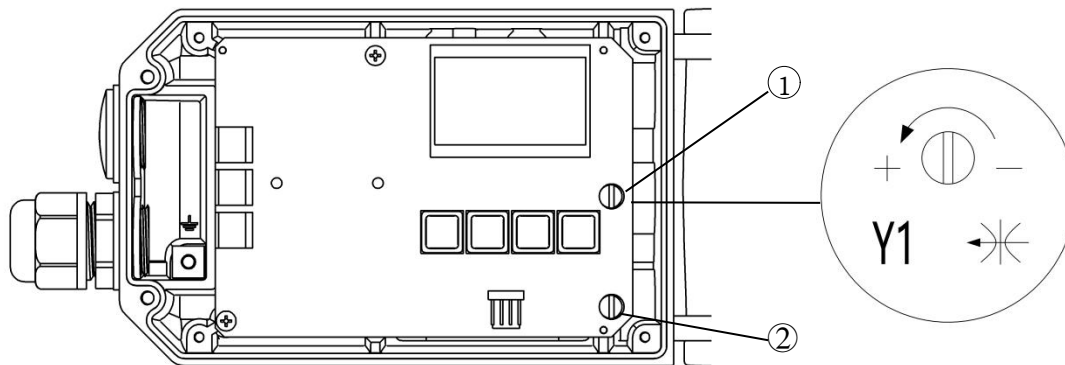
精度不好（线性、滞后现象）	供气压力发生变动	请确认供气压力减压阀是否有异常
	定位器安装螺栓松动	请确认定位器的安全螺栓紧固
	定位器和执行器的连接部有间隙	请确认定位器的连接方式
	设定值有偏差	请对电流源输出信号进行调整
		对设定信号进行校正
其他	请向本公司询问	

10. 保修条款

1. 发现产品有质量问题，经我公司人员确认后，客户享有在质保期内免费更换或维修的售后服务。服务响应时间为 24 小时（非工作日除外）。
2. 产品的质保期以本公司最新质保政策为准，不低于售出后 12 个月。
3. 如下情况的返修品，不属质保范围：
 - (1) 超过质保期的产品。
 - (2) 未经我公司授权和允许，私自拆装过的产品。
 - (3) 未按产品使用说明书操作或其他人为因素造成的产品损坏，包括但不限于：
 - 1> 产品表面有碰撞伤痕。
 - 2> 接线或供电错误造成元器件损坏。
 - 3> 零部件或配件丢失。
 - 4> 未加装过滤减压阀或油雾分离器导致油污进入产品内部造成元器件损坏。
 - 5> 未按使用规范使用防水电气接头导致产品损坏。
 - (4) 不可抗拒因素（自然灾害）造成产品故障或损毁。
4. 不属于产品质保范围的维修，我公司将视实际情况提供免费或收费维修服务。
5. 本条款自双方签定供货合同时生效。

Contents

1. Overview	52
2. One-key automatic initialization	52
3. Selection and ordering data	54
4. Technical data	55
5. Connection description	56
6. Dimension	57
6.1. Mechanical dimension	57
6.2. Mounting bracket dimension	58
6.3. Dimension of linear stroke feedback lever	62
6.3.1. Feedback lever A (with driving pin)	62
6.3.2. Feedback lever B (without driving pin)	62
6.4. Sensor dimension for remote type	63
7. Installation	64
7.1. Linear stroke (normal type or remote type)	64
7.2. Rotary stroke (normal type or remote type)	76
8. Operation	83
8.1. Interface description	83
8.2. Display and operation of main interface	84
8.3. Menu and functions	85
8.3.1. Display and operation of menu	85
8.3.2. Functions description and operation	86
8.3.2.1. TYPE	86
8.3.2.2. INITA	86
8.3.2.3. INITM	86
8.3.2.4. CAL	87
8.3.2.5. SDIR	88
8.3.2.6. CHAR	88
8.3.2.7. FREE	90
8.3.2.8. DB	91
8.3.2.9. LIM	92
8.3.2.10. YDIR	92
8.3.2.11. CUT	93

8.3.2.12.	POS	94
8.3.2.13.	FACT	95
8.3.2.14.	WP	95
8.3.2.15.	ACT	96
8.3.2.16.	REF	96
8.3.3.	Error message during initialization	96
8.3.4.	Tips of menu option or function cannot access	97
8.3.5.	Menu function options summary description	97
8.4.	Feedback signal	99
8.5.	Adjust air flow	99
9.	Trouble shooting	101
10.	Warranty terms	102



1. Overview

IP5500 series intelligent valve positioner is mounted on pneumatic actuators. It's used to control air intake and exhaust of the pneumatic actuators to drive the valve position to the set point by calculating both data from 4-20 mA DC signal and feedback position.

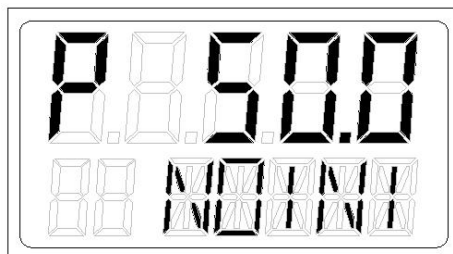

2. One-key automatic initialization

1. Please read the installation instructions in **chapter 7** before installing the positioner. Install the positioner according to the installation requirements described. Please pay attention to some installation points. For example, confirm the initial position of the feedback axis of the positioner or remote sensor before installation. Do not turn the feedback axis 360° during installation. For the positioner of normal linear type, make the upper plane of the positioner housing at a right angle to the main stem of the valve. Within the valve stroke range, the rotation angle of the positioner feedback lever meets the installation requirements.
2. After installing the positioner on the valve, connect the air source and electrical cables. Ensure that the air source pressure can fully open the valve. Power on the positioner by DC 24V.
3. After the positioner is powered on, Positioner is in the uninitialized state before initialization. When LCD displays the sign **NOINI**, interface displays percentage value of sensor in the top line. As shown below.



In this state, pressing   buttons can open and close valve. Open and close valve fully, and observe the percentage value of sensor displayed on the interface. For non-separate type, ensure that within the entire valve stroke range, the minimum sensor percentage value $\geq 2\%$, and the maximum sensor percentage value $\leq 98\%$. Otherwise, it is necessary to re-adjust the

installation position to make the linear stroke feedback lever or the angle stroke adapter move within the effective range. In addition, the minimum and maximum percentage difference of the sensor is required to be greater than 16%.

4. The actuator type has been set before the positioner leaves the factory. The user only needs one-key operation to execute the automatic initialization (**INITA**) function to complete the matching of the valve. In the initial interface (**NOINI**) or manual / automatic mode interface, press and hold  button for approx. 3s to run the automatic initialization. After the initialization is completed, **FINSH** is displayed on the LCD, press  button to exit. After exiting, the system enters the manual mode interface, press  button again to switch to the automatic mode. At this time, the user can control the valve position through the 4-20mA signal. For some reasons, the system will display an error message in the function option line during the automatic initialization process and the automatic initialization will be interrupted. Descriptions of error messages and solutions are showed in chapter 8.3.3.

3. Selection and ordering data

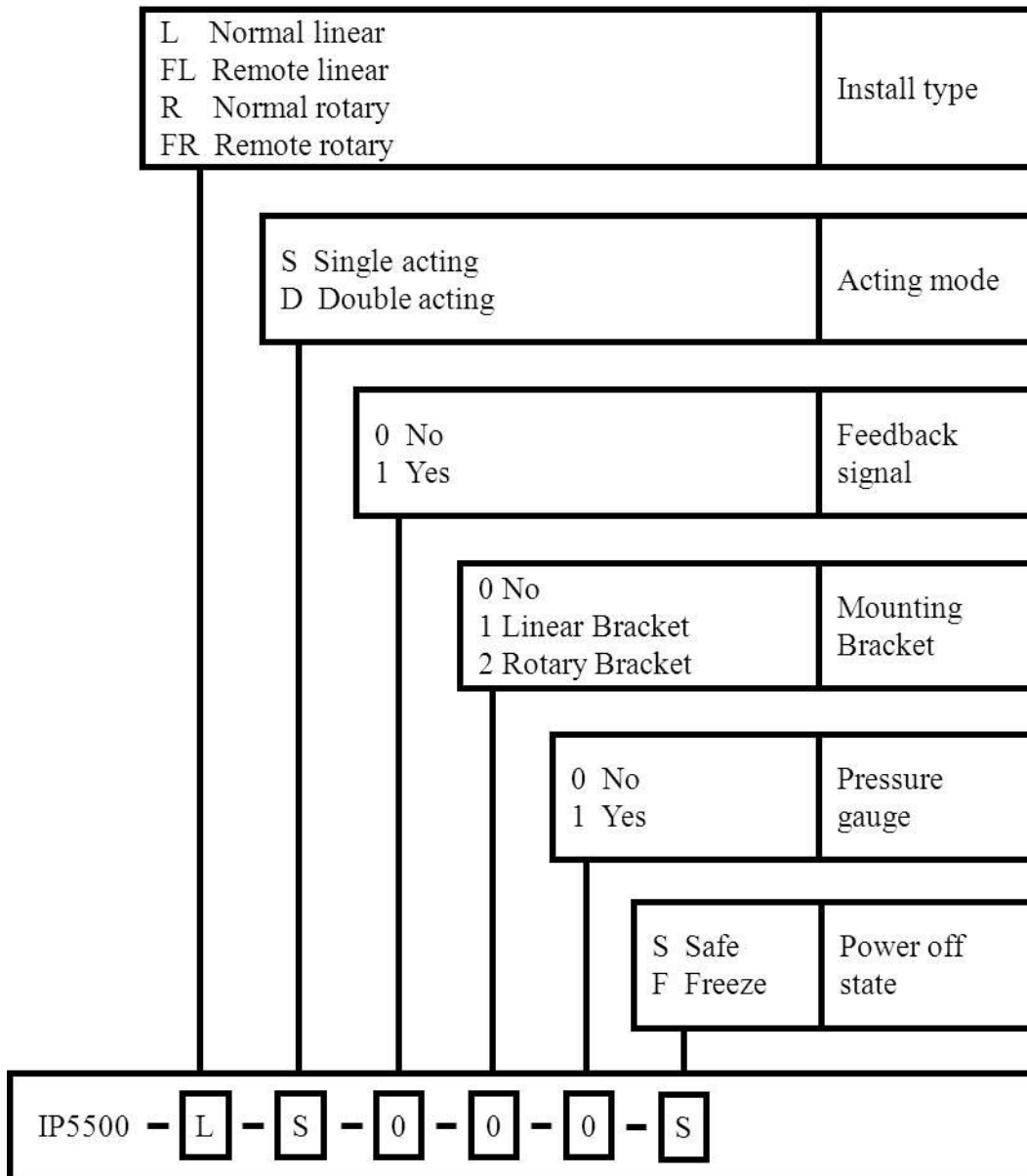

4. Technical data

Material	Aluminum
Power supply	24V DC $\pm 10\%$
Set-point Signal	4~20mA DC
Ambient Temperature	0~50°C
Gas Source Requirement	ISO 8573-1 <ul style="list-style-type: none"> ● Solid particle size and density Class 3 ● Dew point Class 3 ● Oil content Class 3
Vibration Resistance	0.15mm,10Hz-60Hz,20 cycle/axis 20m/ s ² ,60Hz-500Hz,20 cycle/axis Recommended range for control valve ≤ 20 m/s ² , no resonance peak
Supply Pressure	0.14~0.7MPa
Flow	75L/min (Sup=0.14MPa)
Basic error	$\leq 0.5\%$
Hysteresis error	$\leq 0.5\%$
Electrical Connection	M20×1.5
Pneumatic Connection	G1/4
Weight	1.5 kg
Protection Class	IP69K

5. Connection description

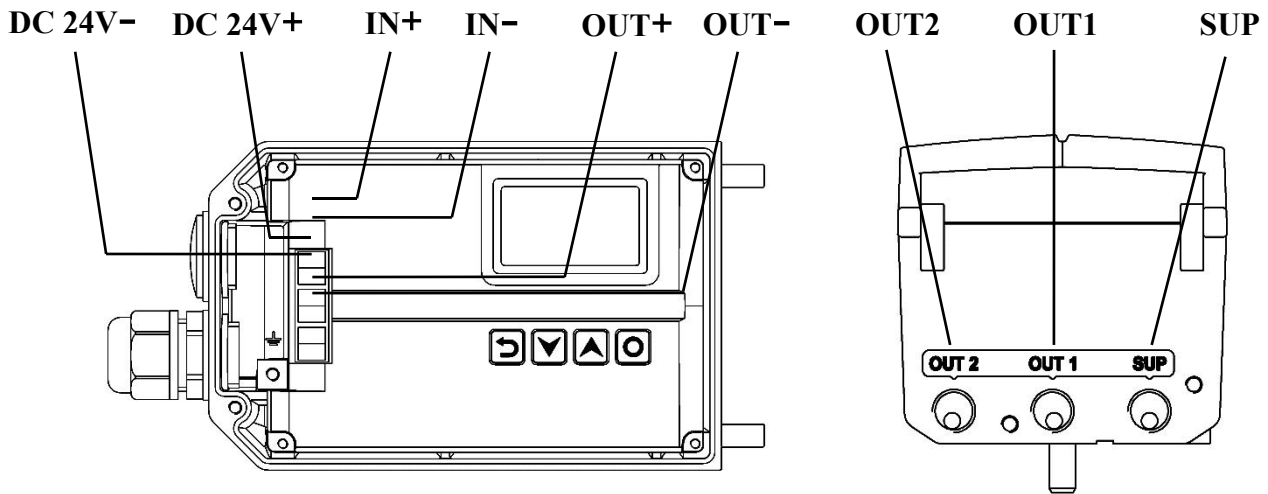

Figure 1. Connection description

Electrical Connection	Description
IN+	4-20 mA set-point signal +
IN-	4-20 mA set-point signal -
DC 24V +	Power supply DC 24V +
DC 24V -	Power supply DC 24V -
OUT+	4-20 mA feedback signal +
OUT-	4-20 mA feedback signal -

Pneumatic Connection	Description
SUP	Air supply enter
OUT1	Pilot air outlet 1
OUT2	Pilot air outlet 2, used for double acting type.

NOTES:

- Electrical cables must use shielded twisted pair or shielded wires. Connect one end of the cable shielding layer to the \perp screw outside the casing or the \perp screw inside the casing, and the other end to the ground. So that the device is effectively grounded to prevent electromagnetic interference.
- Keep electrical cables away from strong magnetic fields.
- Must install or remove the electrical cable when the device is powered off.

6. Dimension

6.1. Mechanical dimension

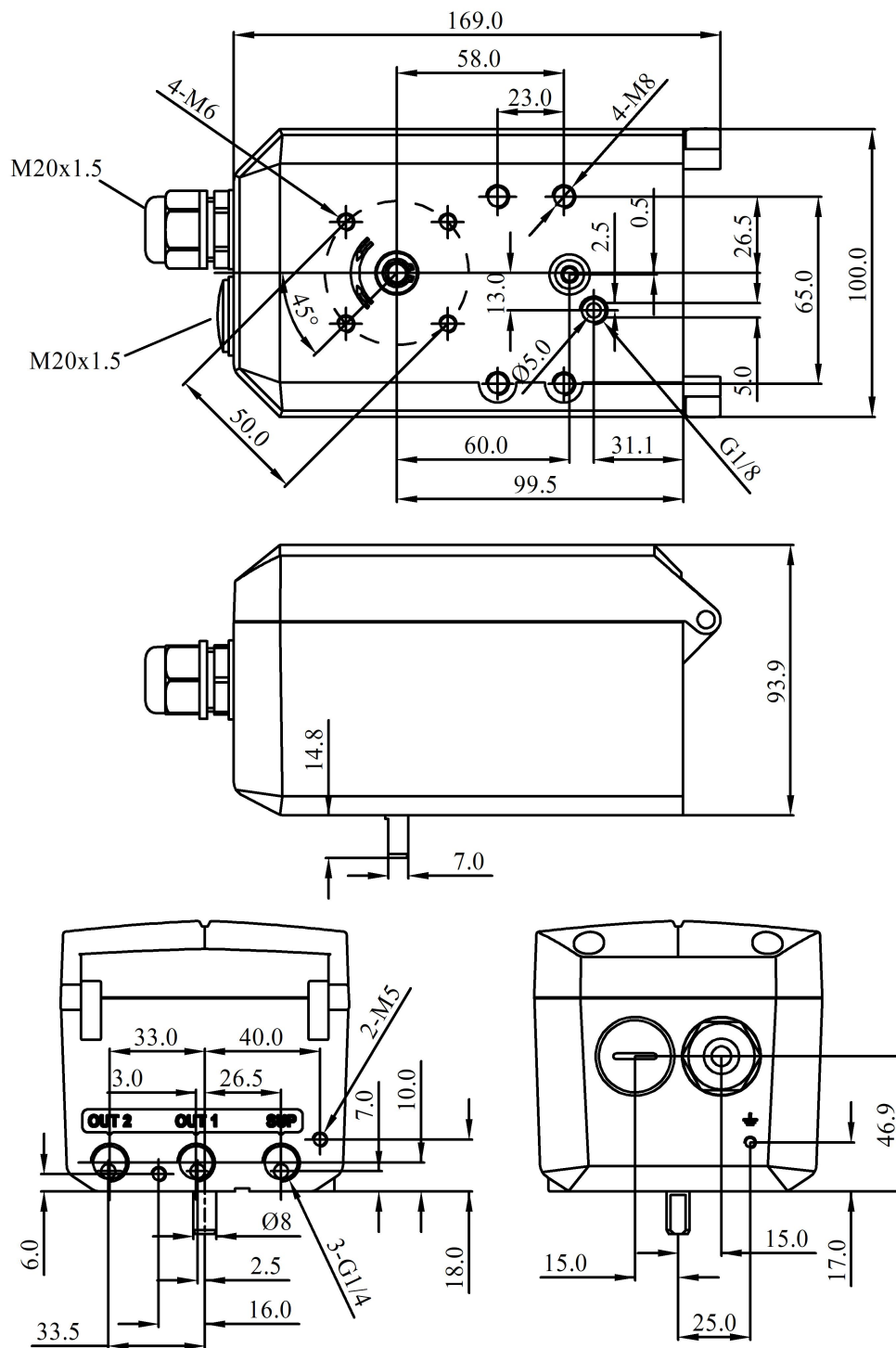

Figure 2. Mechanical dimension

6.2. Mounting bracket dimension

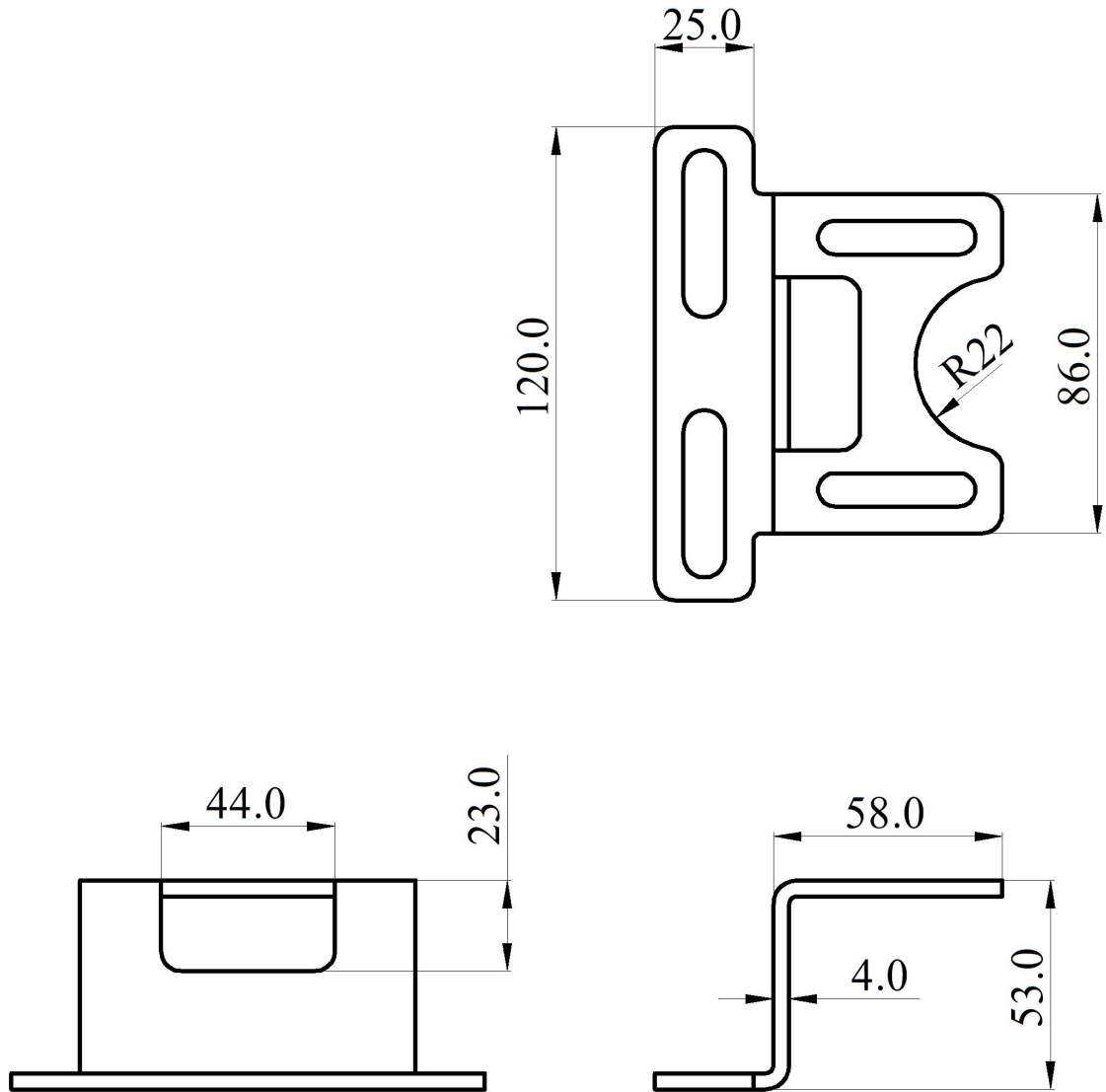

Figure 3. Normal linear mounting bracket

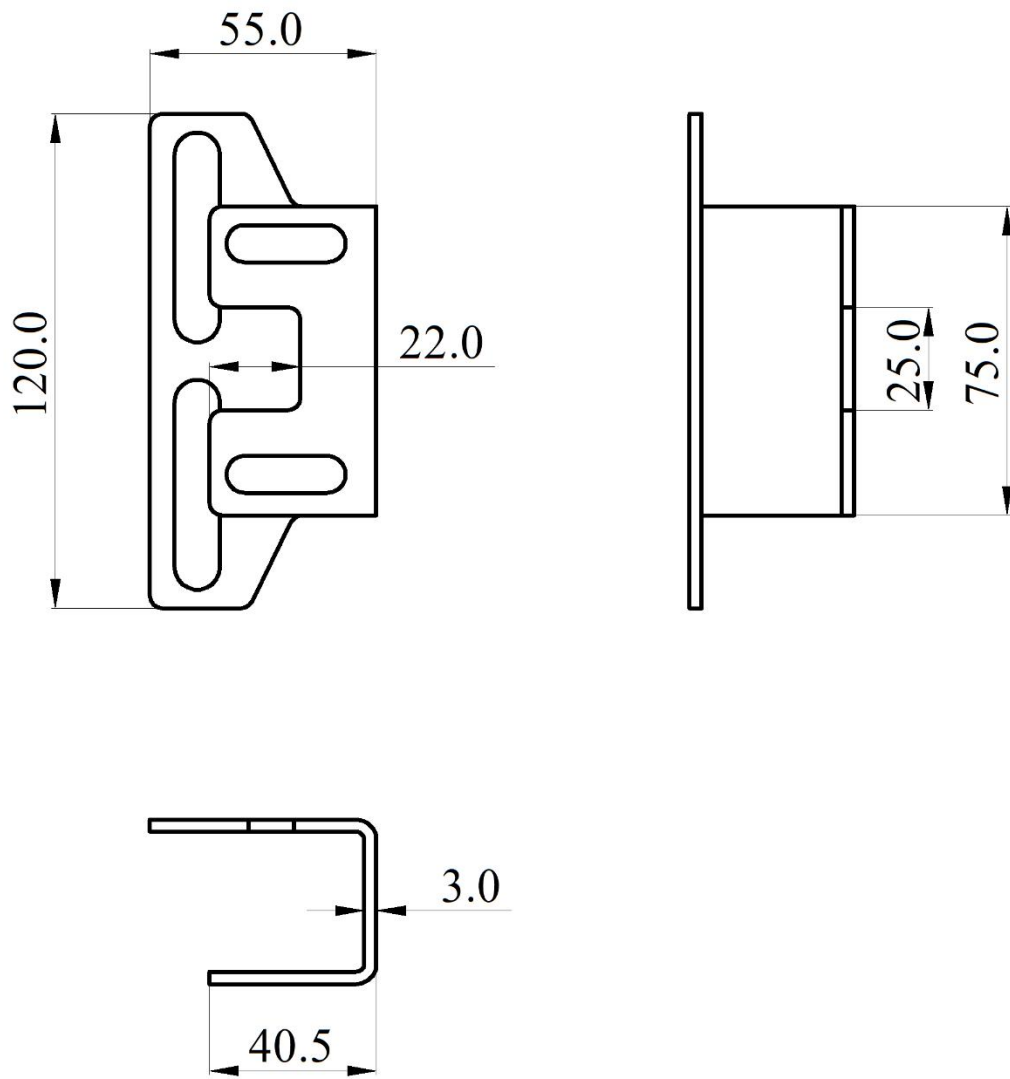

Figure 4. Remote linear mounting bracket

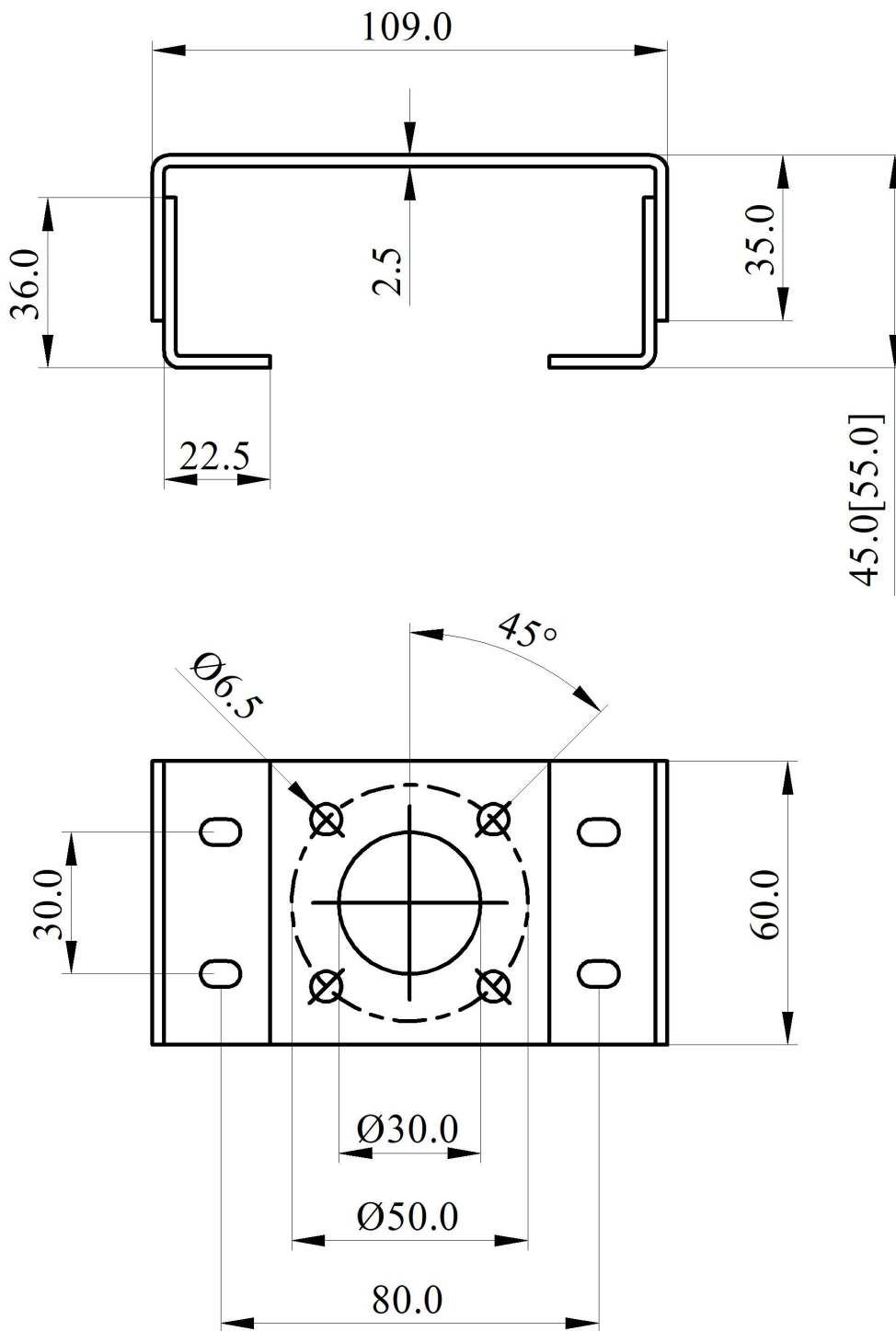

Figure 5. Rotary mounting bracket (Type A)

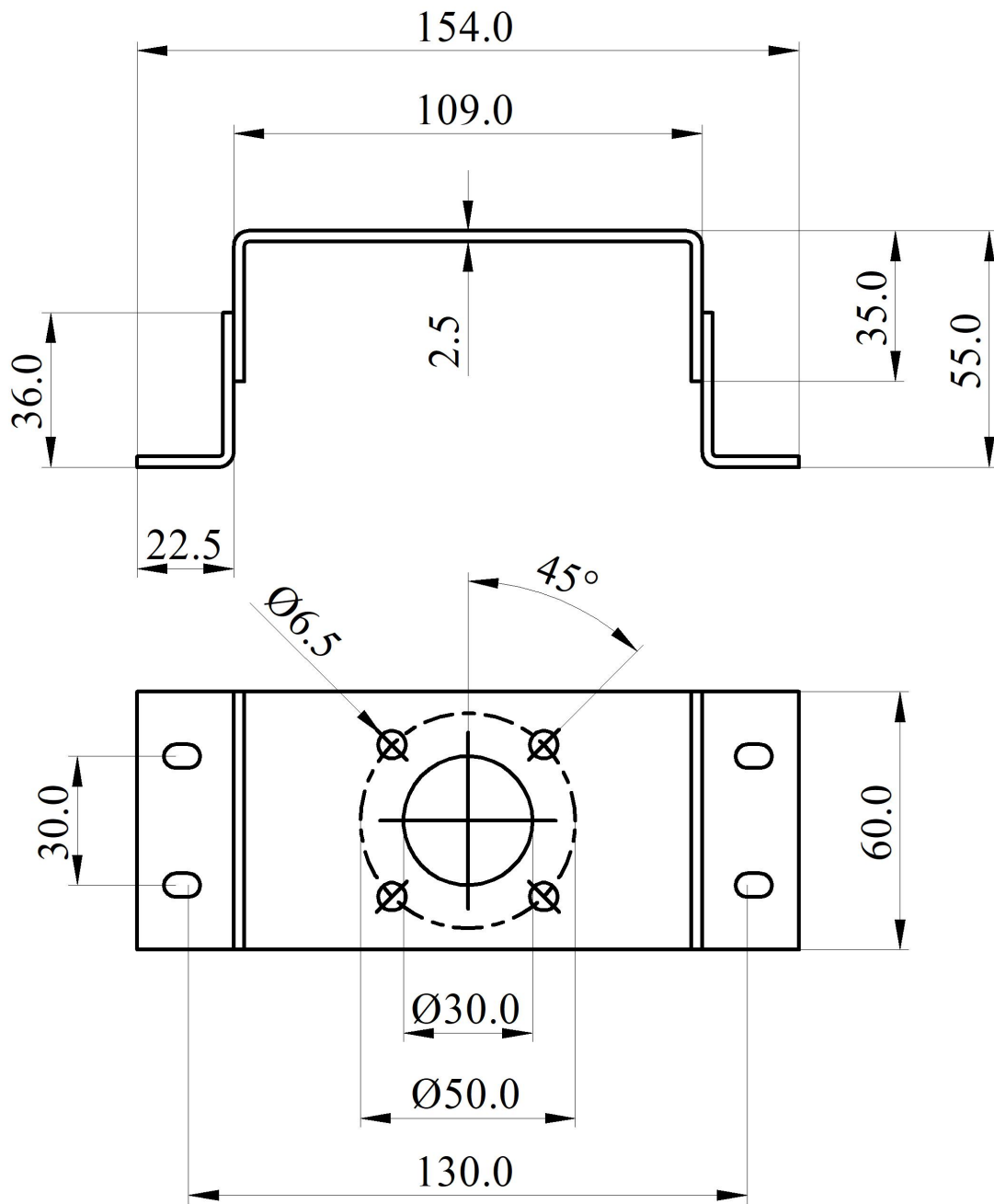

Figure 6. Rotary mounting bracket (Type B)

6.3. Dimension of linear stroke feedback lever

6.3.1. Feedback lever A (with driving pin)

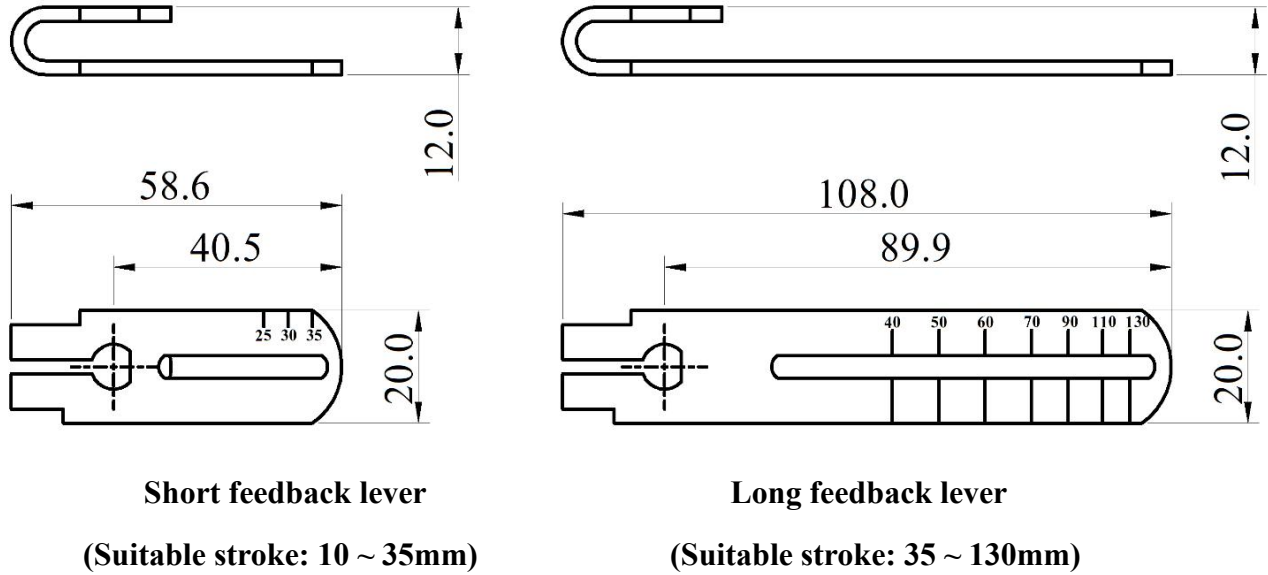

Figure 7. Dimension of feedback lever A

6.3.2. Feedback lever B (without driving pin)

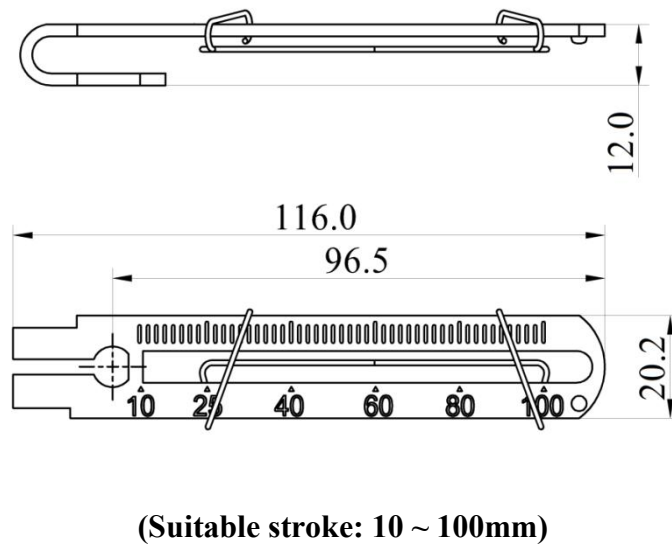

Figure 8. Dimension of feedback lever B

6.4. Sensor dimension for remote type

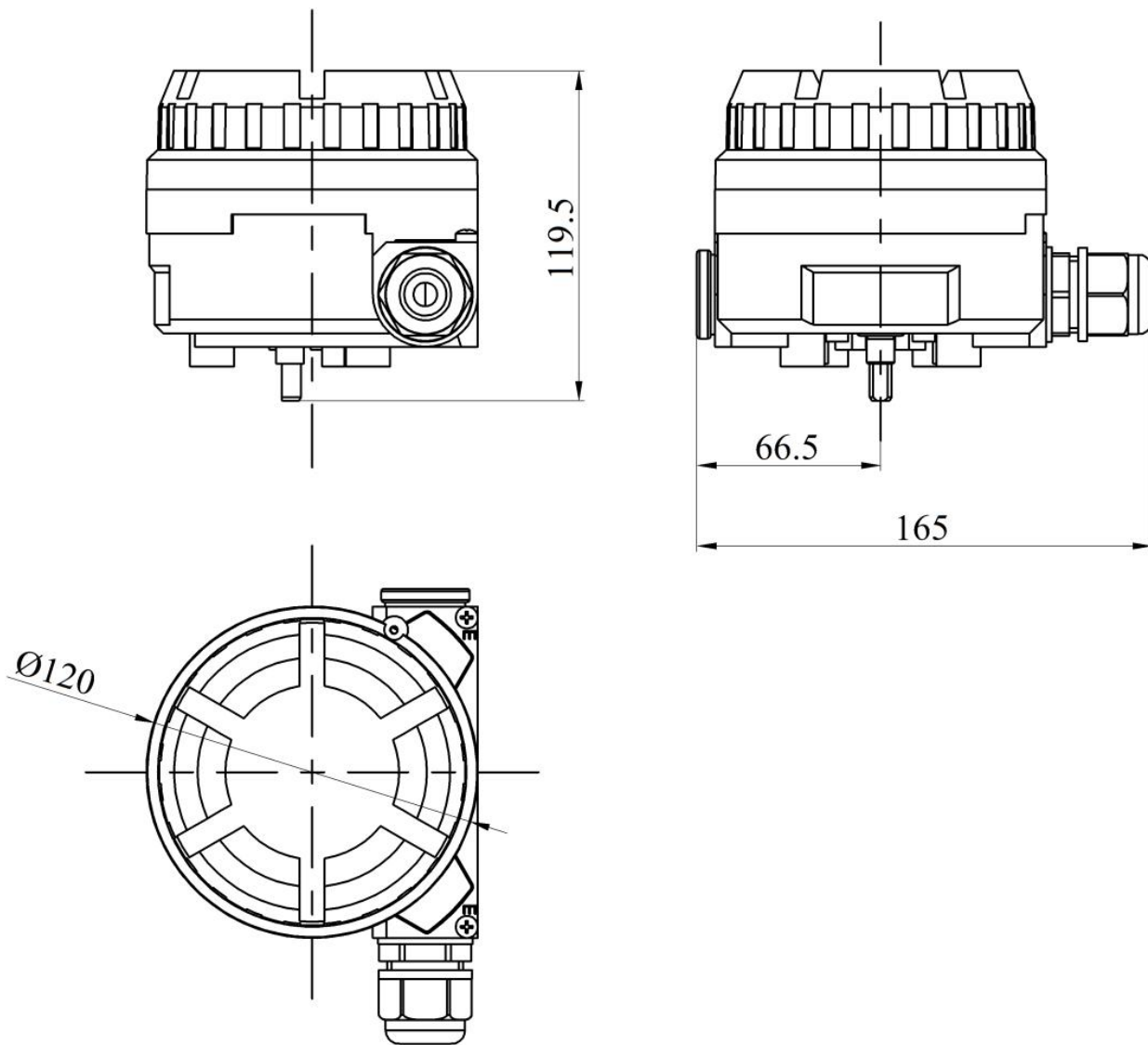

Figure 9. Sensor dimension for remote type

7. Installation

7.1. Linear stroke (normal type or remote type)

Linear actuator mounting components			
No.	Name	Amount	Note
①	U-shaped rod	1	Rotate the feedback lever in the working process
②	Clamping assembly	1	Mount U-shaped rod to actuator
③	M6 hexagon socket screw	2	M6×25
④	M6 spring washer	2	Prevent screw loosening
⑤	feedback lever	1	Mounted on the main stem of the positioner
⑥	M6 hexagon socket bolt	1	M6×20, match with square nut
⑦	Linear stroke mounting bracket	1	Connect positioner and actuator
⑧	M8 hexagon head bolts	2	M8×10
⑨	M8 spring washer	2	Prevent bolts loosening
⑩	M8 flat washer	2	Protect contact surface
⑪	Driving pin for feedback lever B	1	Mounted on the main stem of the valve

1. Confirm the initial position of the feedback axis of the positioner or the remote sensor

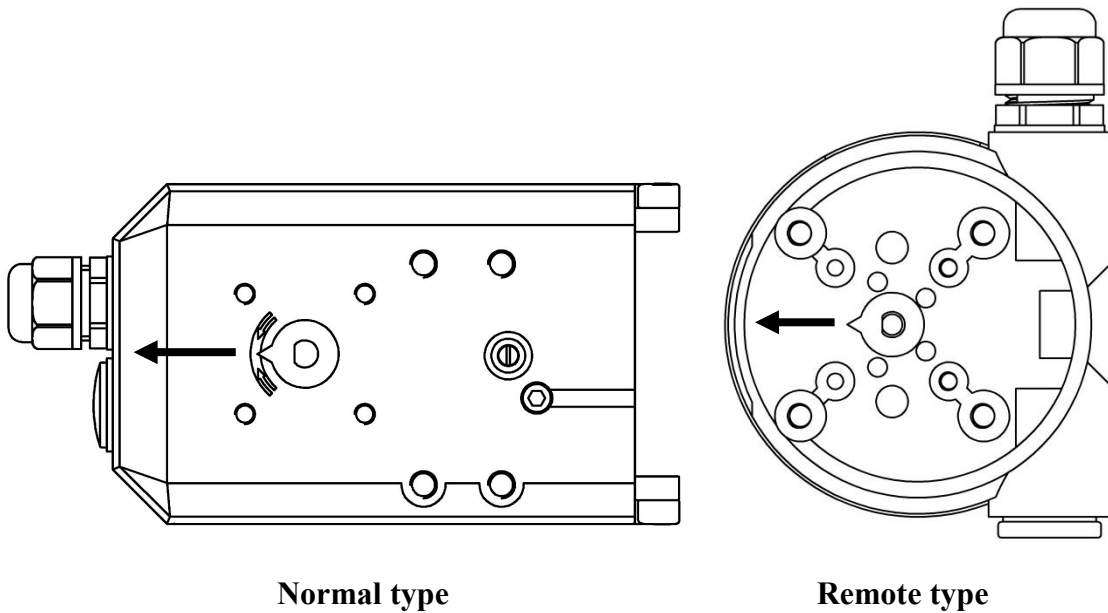

Figure 10. Initial position of the feedback axis

Rotate the feedback axis and point the pointer on the feedback axis in the direction of arrow in Figure 10. The direction of arrow is defined as the initial position. Power on the positioner, observe the percentage value of the sensor on the initial interface (NOINI), and confirm that the value is between 40-60%. If not, turn the feedback axis 360° and confirm again. After confirmation, power off the positioner.

2. Install the U-shaped rod that matches the feedback lever A or the driving pin that matches the feedback lever B to the actuator.

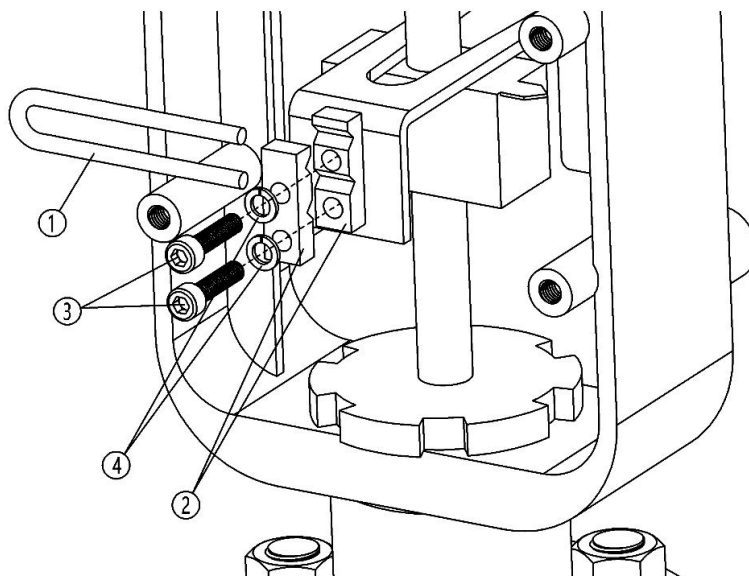

Figure 11. U-shaped rod installation

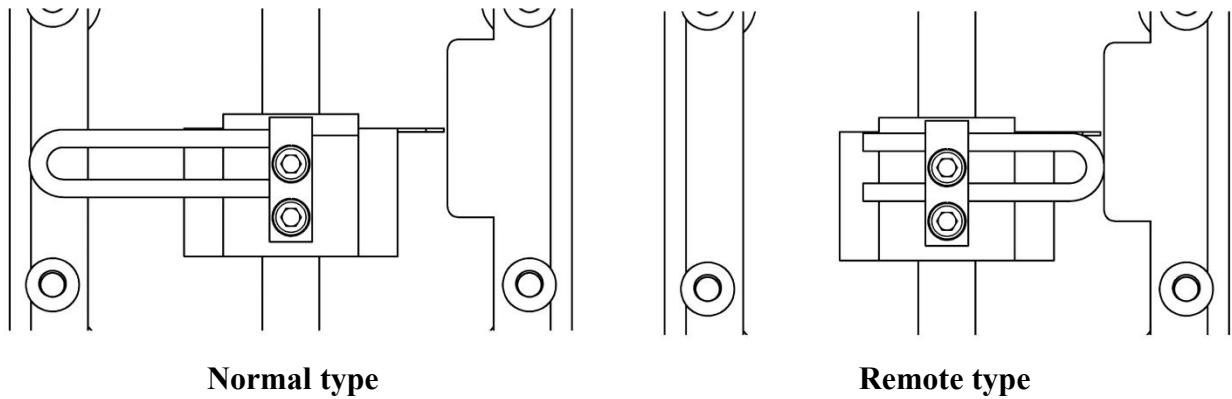

Figure 12. U-shaped rod direction

Fix U-shaped rod ① and Clamping assembly ② on the actuator center spindle with M6 hexagon socket screw ③ and M6 spring washer ④, and tighten screws with a hexagon socket wrench.

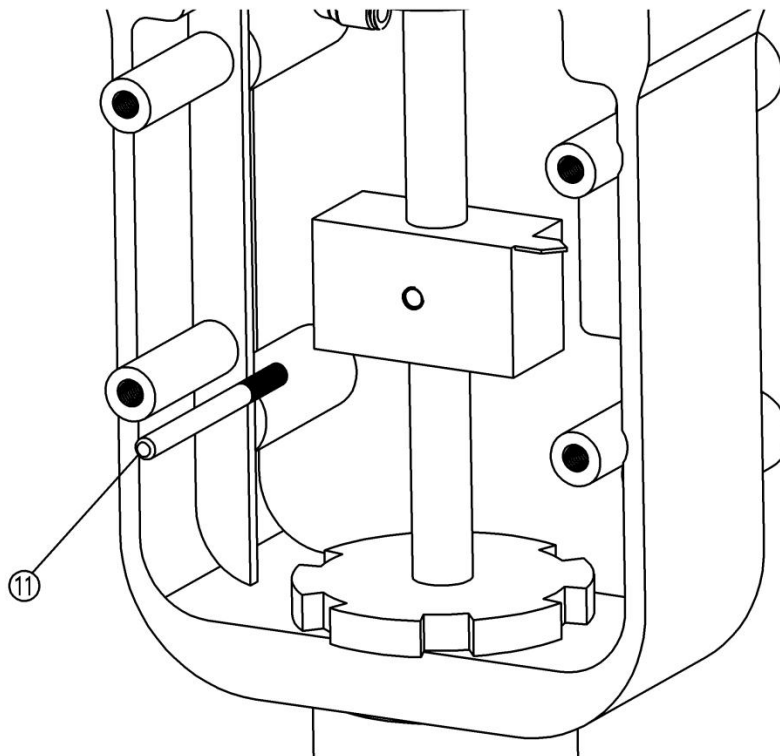

Figure 13. Driving pin installation

Install the driving pin ⑪ on the main stem of the valve. The slot height of the feedback lever B is 6.2 mm. Therefore, if the user does not use the provided driving pin, it should be noted that the diameter of the driving pin used is 6 mm, and the thread size of the driving pin and the main stem of the valve must be the same.

3. Install the driving pin that matches the feedback lever A.

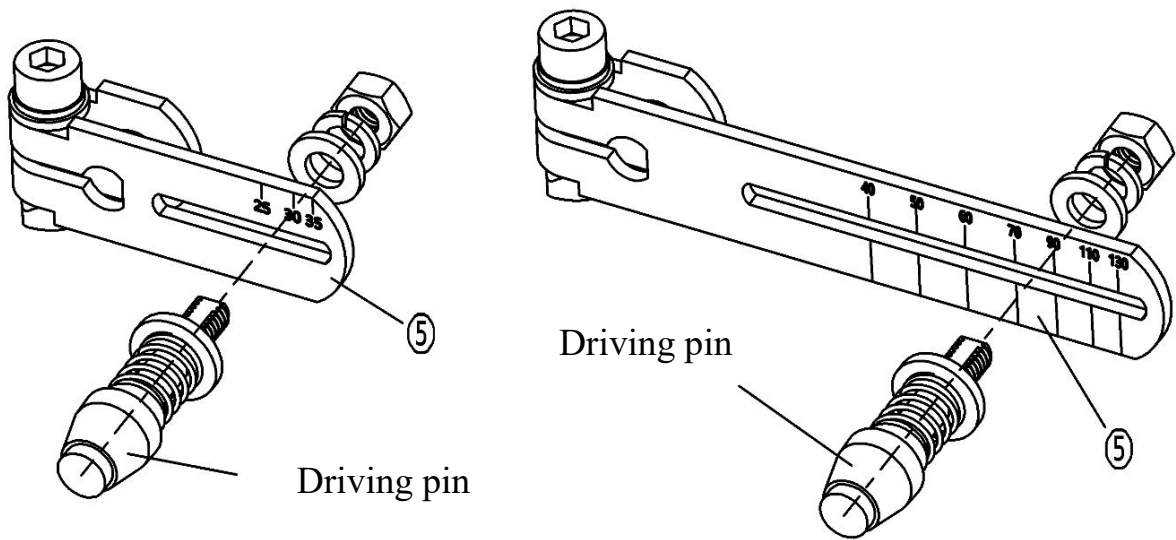

Figure 14. Driving pin that matches the feedback lever A installation

Select the feedback lever corresponding to the figure above according to valve actual stroke. The pin must be mounted at the corresponding stroke scaling value at the feedback lever, if it's not, the lever may be damaged when the valve is activated. For example, mounting driving pin at value 40 position for a valve with 100mm stroke, the feedback lever may be deformed when the valve is activated. If the valve stroke is out of the range of feedback lever A, please consult the manufacturer.

4. Mount feedback lever and linear mounting bracket to the positioner or the remote sensor.

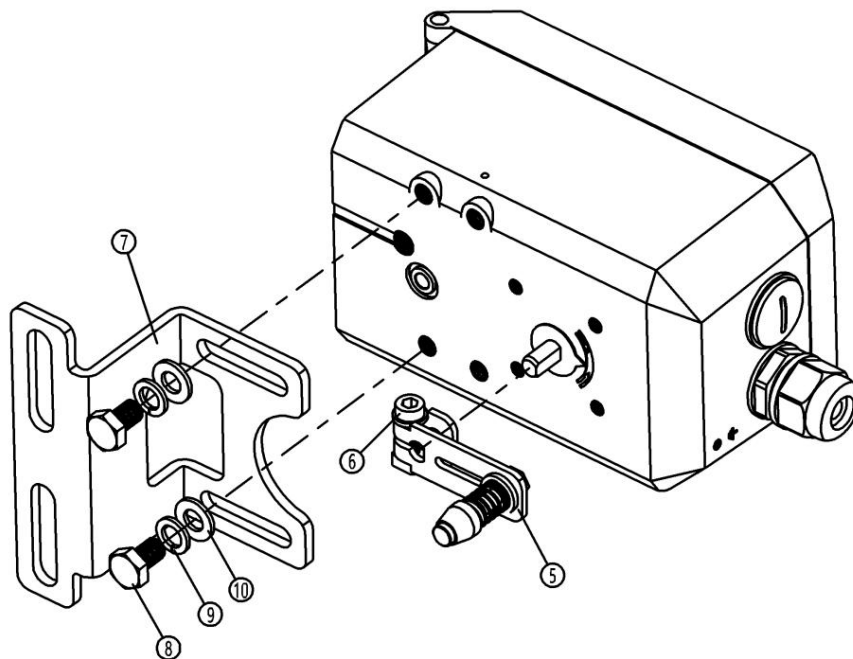

Figure 15. Feedback lever A and mounting bracket installation (normal type)

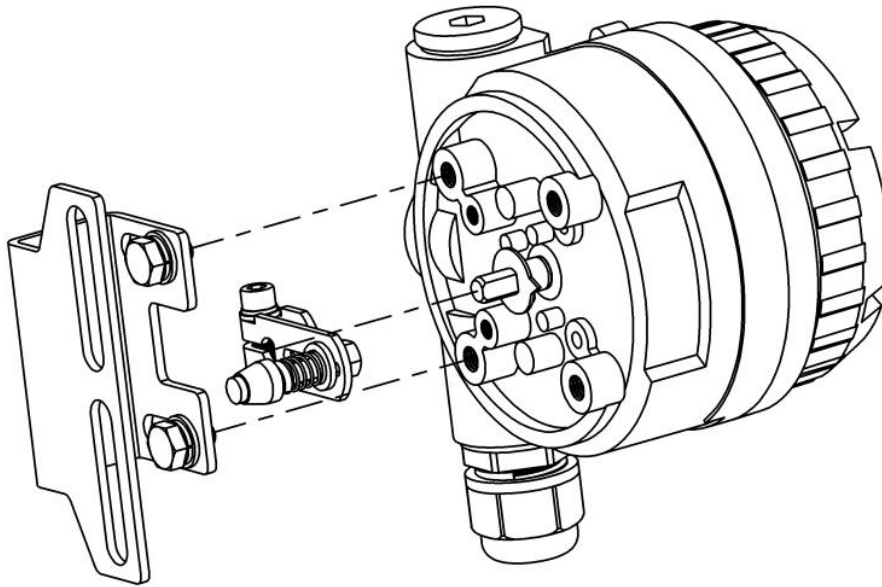

Figure 16. Feedback lever A and mounting bracket installation (remote type)

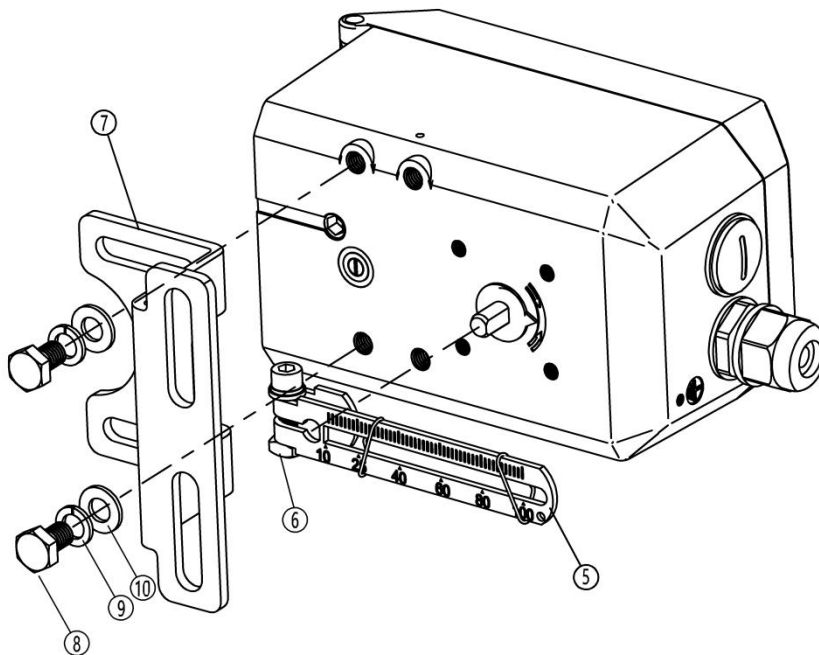

Figure 17. Feedback lever B and mounting bracket installation (normal type)

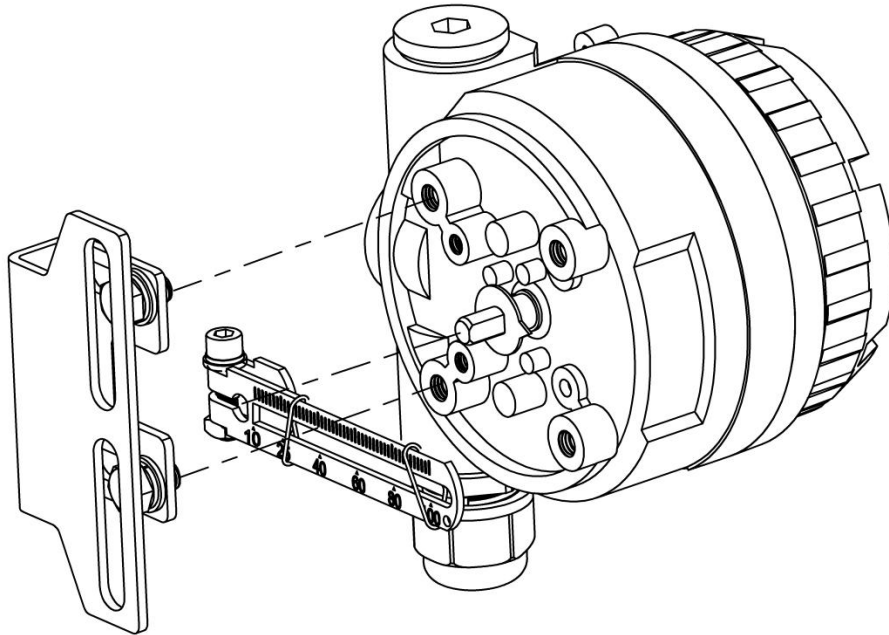

Figure 18. Feedback lever B and mounting bracket installation (remote type)

- Mount the feedback lever A or B ⑤ to the feedback axis on the rear of the positioner or the remote sensor.
 - Check whether the NUMAR lever stroke is within the operational range regarding to the arrow mark.
 - Fix the hexagon socket bolt⑥ with hexagon socket wrench.
 - Pre-fasten the mounting bracket⑦ to the positioner or the remote sensor with hexagon head bolts⑧, spring washer⑨ and flat washer⑩.
5. Fix linear mounting bracket to the actuator.

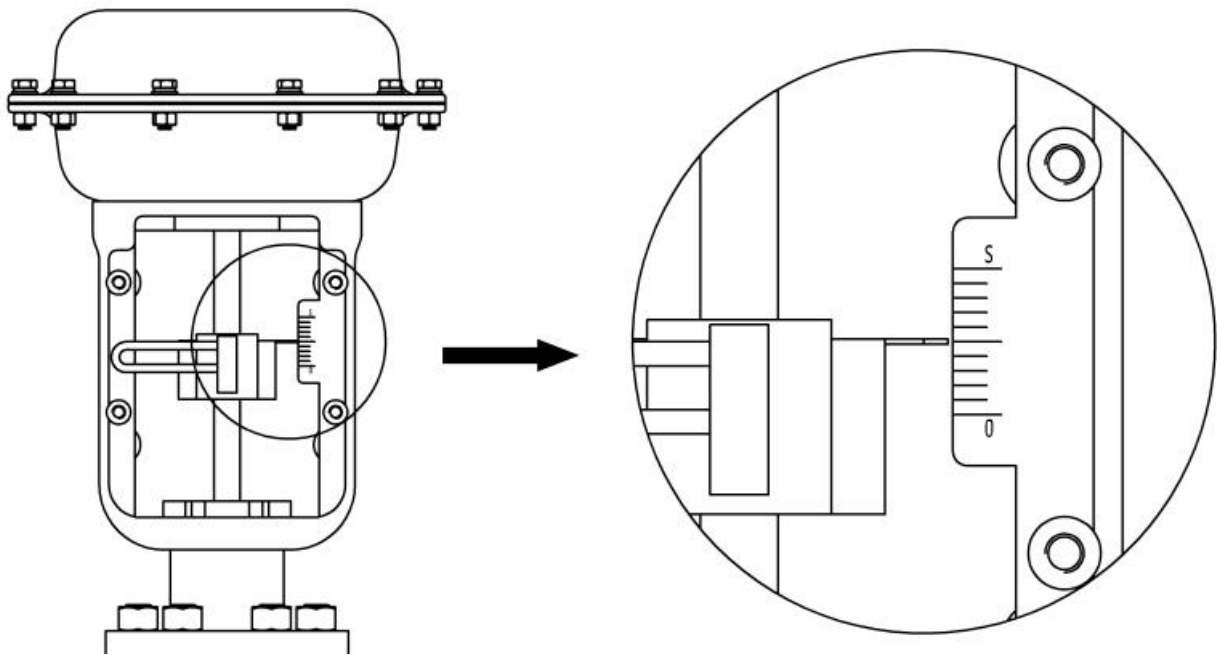

Figure 19. Valve mid-stroke point

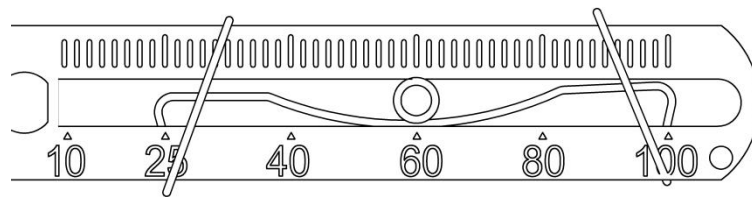

Figure 20. Feedback lever B and driving pin connection

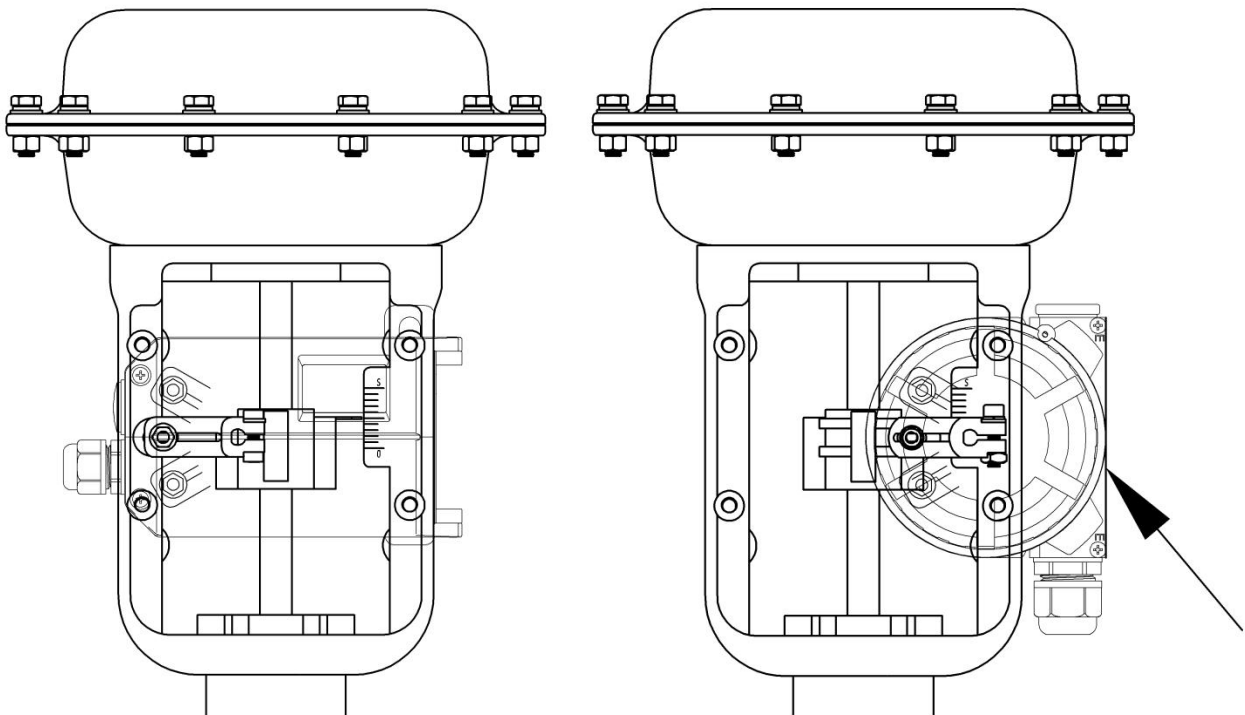

Figure 21. Installation with actuator (Feedback lever A)

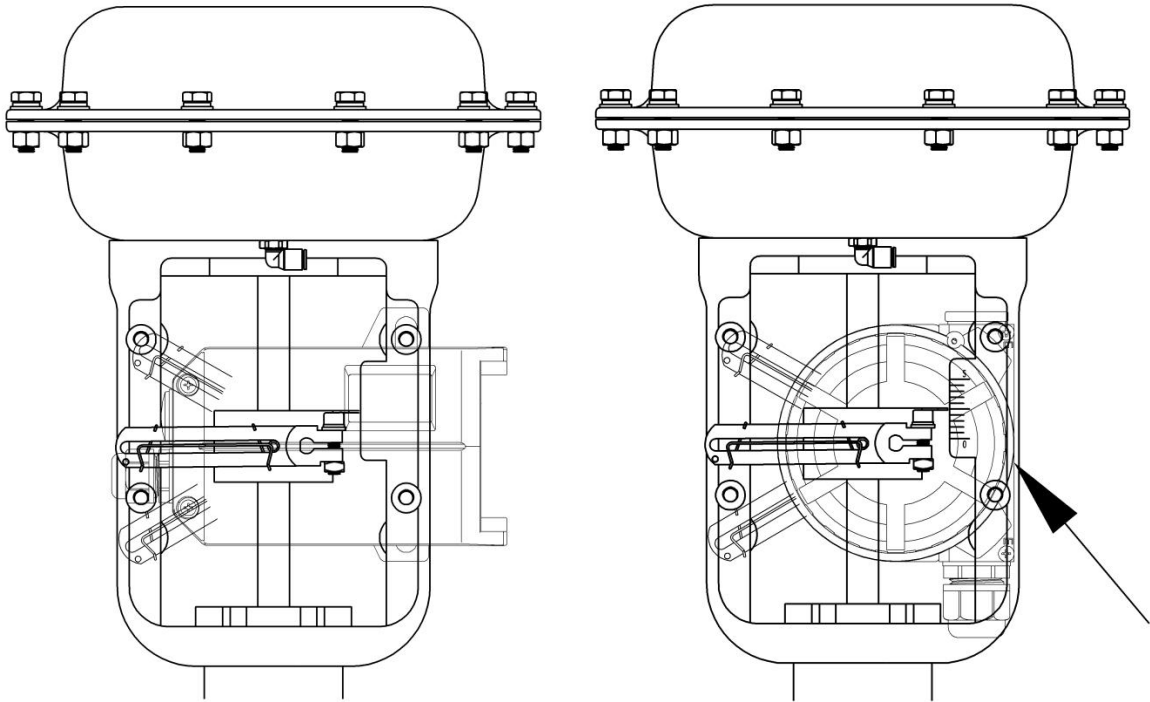

Figure 22. Installation with actuator (Feedback lever B)

- Input air to the valve cylinder, adjust the valve position to the mid-stroke point according to the stroke ruler on the valve, as shown in Figure 19.
- For feedback lever A, hold the linear stroke mounting bracket⑦ against the actuator. Plug the head of feedback lever⑤ into the U-shaped rod①. For feedback lever B, insert the driving pin⑪ into the fixed spring in the slot of the feedback lever B, as shown in Figure 20. Make the valve main stem and feedback lever are at right angle. If it cannot be at right angle, install according to the actual situation.
- The whole rotary angle is recommended to be between 40°~90°. User can adjust the distance (Angle rotation radius) between the driving pin and the rotation shaft of the positioner or the remote sensor to change the angle.
- For the positioner of normal linear type, make the upper plane of the positioner housing at a right angle to the main stem of the valve. For the positioner of remote linear type, make the plane indicated by the arrow (on the right side of Figure 21 and Figure 22) on the sensor housing and the main stem of the valve are parallel to each other. Otherwise it will affect the control accuracy. Finally, tighten the bracket with bolts.

6. Overall schematic diagram.

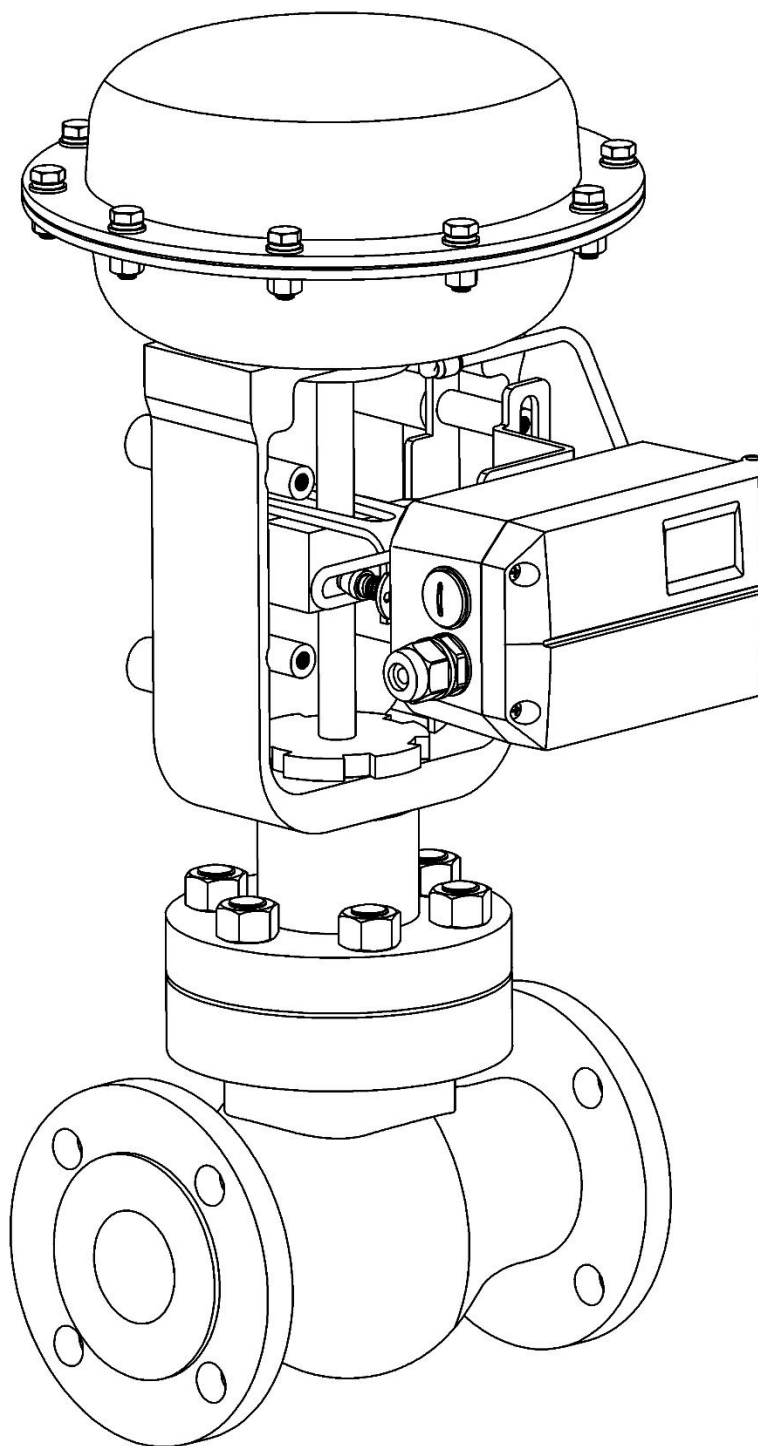

Figure 23. Linear stroke for normal type (Feedback lever A)

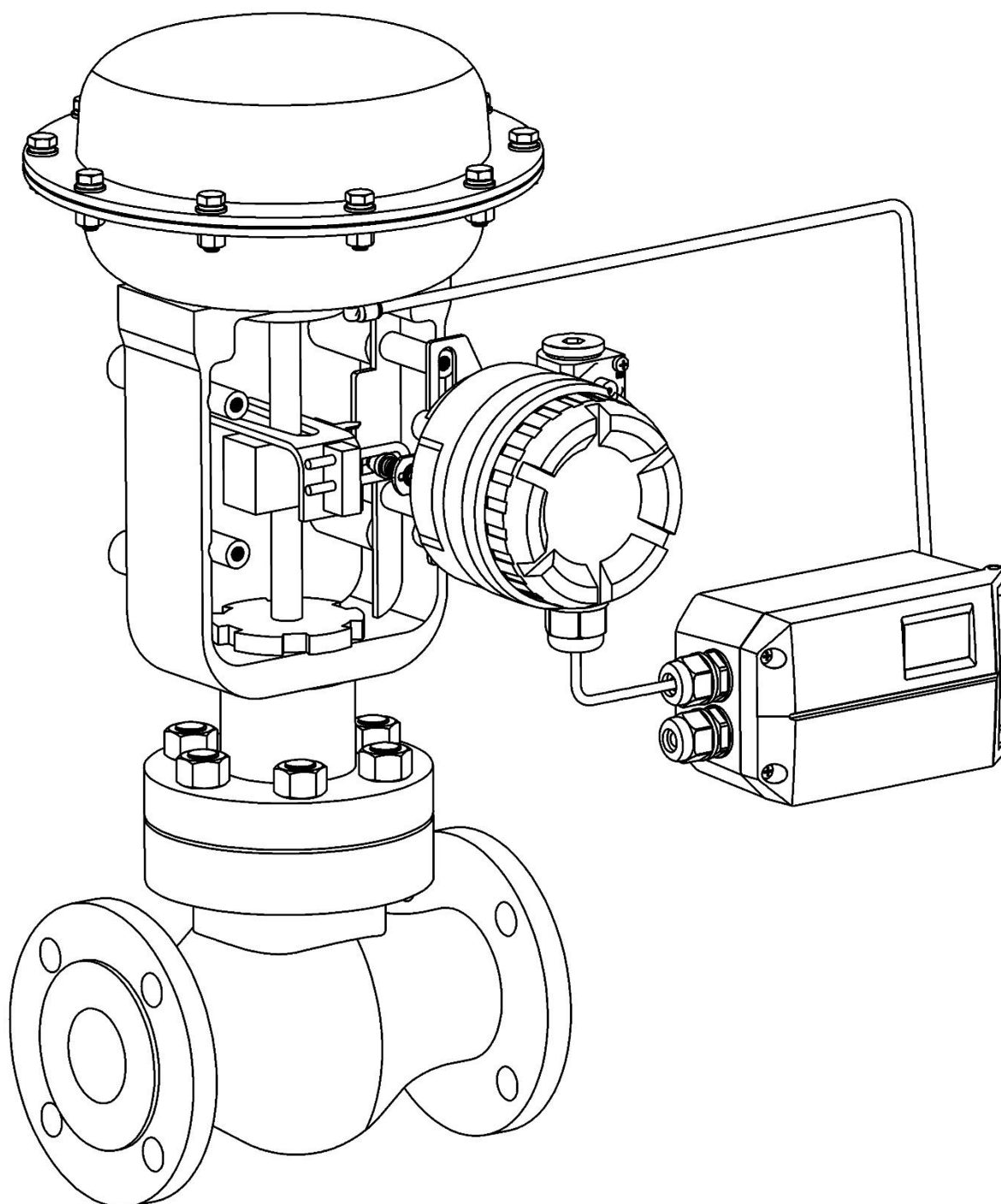

Figure 24. Linear stroke for remote type (Feedback lever A)

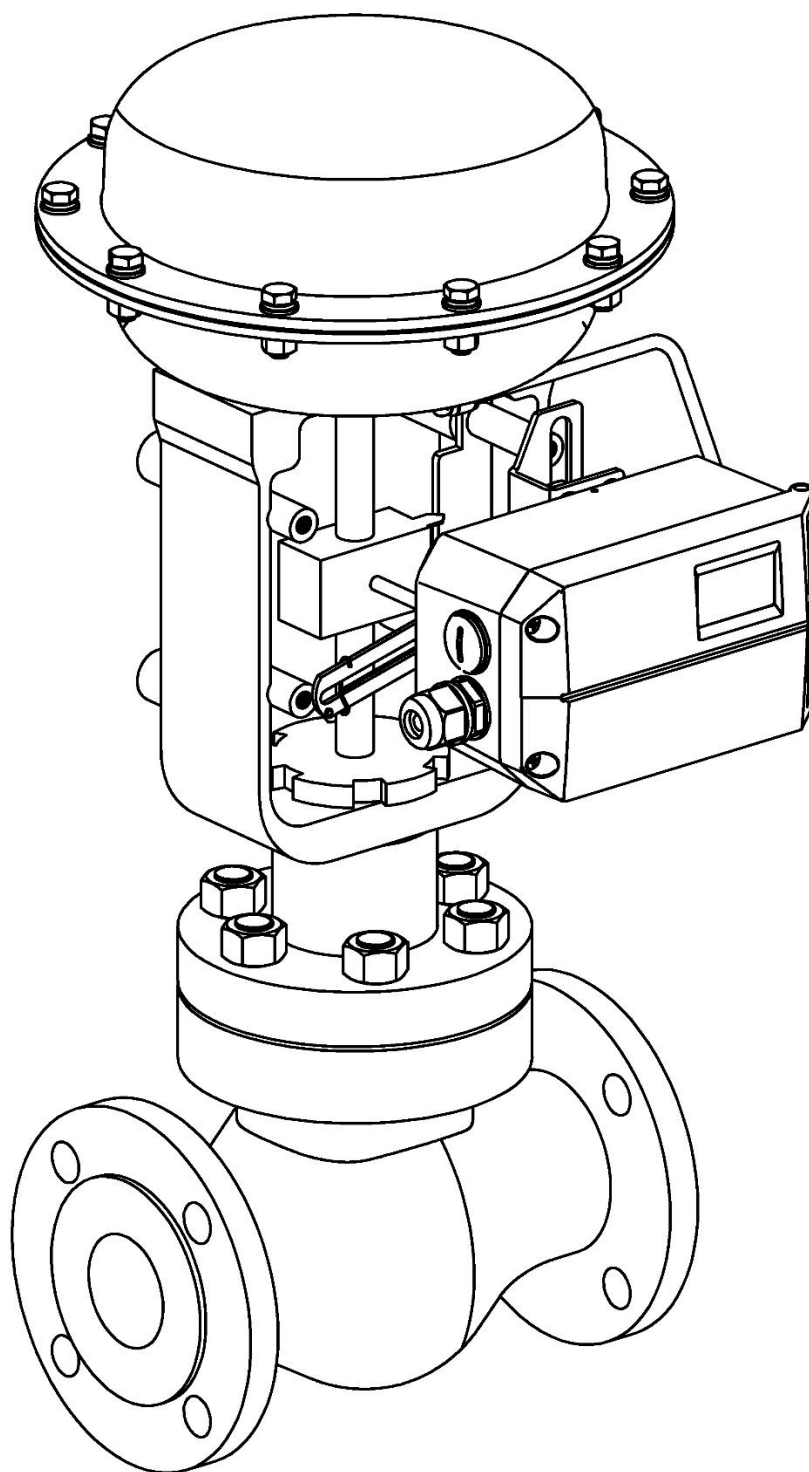

Figure 25. Linear stroke for normal type (Feedback lever B)

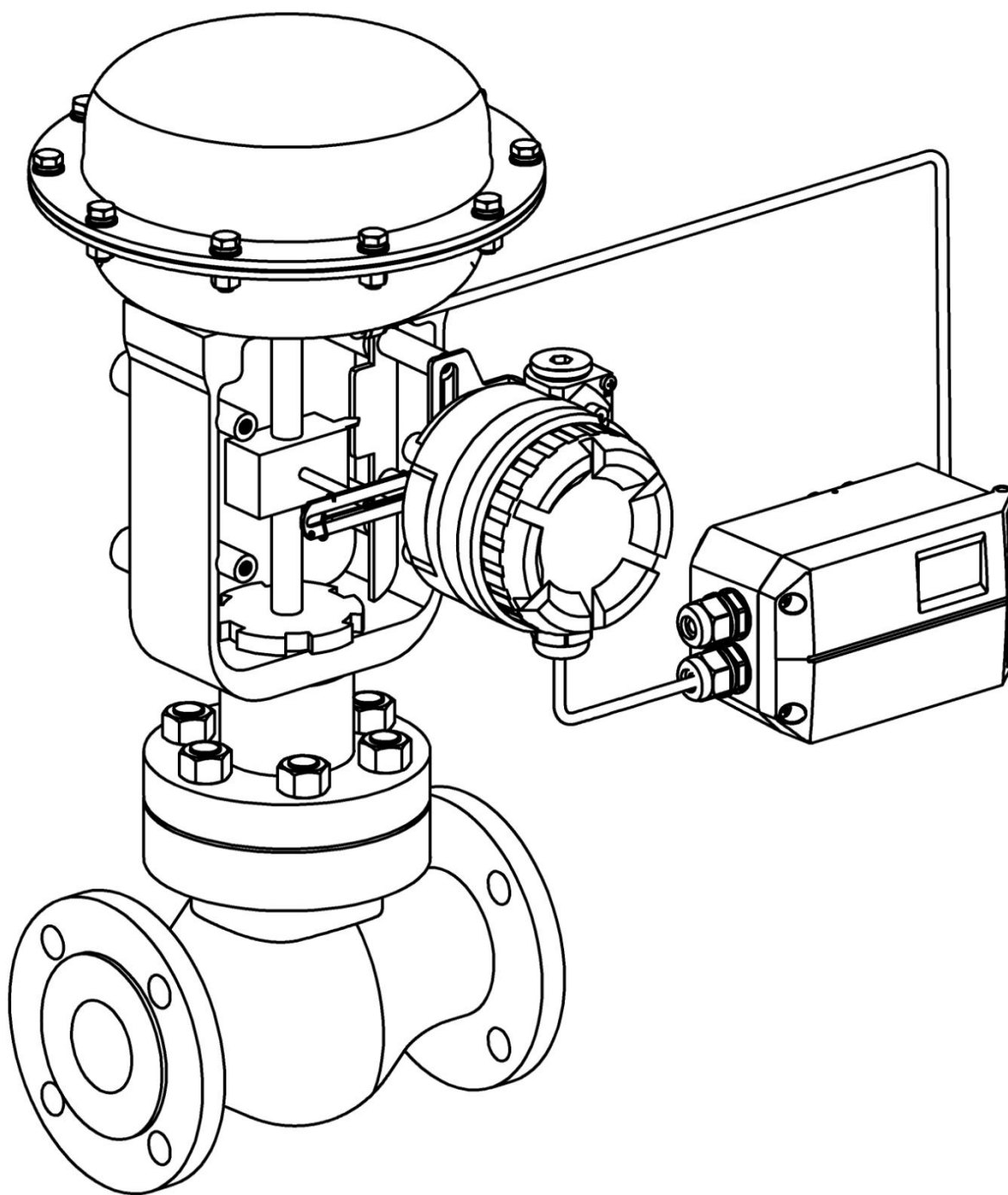

Figure 26. Linear stroke for remote type (Feedback lever B)

7.2. Rotary stroke (normal type or remote type)

Rotary actuator mounting components			
No.	Name	Amount	Note
①	Adapter	1	Mounted on the positioner main stem.
②	Hexagon socket set screw	2	M4×8, fix adapter to the positioner main stem.
③	Rotary stroke mounting bracket	1	Compatible for actuators in different specifications.
④	M6 flat washer	4	Protect contact surface
⑤	M6 spring washer	4	Prevent screw loosening
⑥	M6 hexagon socket screw	4	M6×10
⑦	M5 hexagon socket screw	4	M5×8
⑧	M5 spring washer	4	Prevent screw loosening
⑨	M5 flat washer	4	Protect contact surface

Note before installation:

Please make the following preparations. In the installation steps, the first situation shown in Figure 27 is taken as an example. Figure 27 shows the slot direction and rotation direction of the actuator rotation axis at the initial position. ↓ indicates the position of the actuator pneumatic interface.

- Adjust the actuator rotation axis to the initial position. For single-acting actuators, exhaust the air from the actuator cylinder fully. For double-acting actuators, exhaust the air from one cylinder and fill the air into the other cylinder fully. Pay attention to the slot direction of the rotation axis at the initial position.
- Confirm the direction of rotation of the actuator axis. For single-acting actuators, fill air into the actuator cylinder at the initial position. For double-acting actuators, at the initial position, fill air into the cylinder which the air inside is fully exhausted, and exhaust air from the other cylinder which is filled with air. In this way, the direction of rotation of the rotating axis is

judged.

- Rotate the pointer of the positioner feedback axis to the corresponding position shown in the following picture, and be sure to rotate the feedback axis within the range of the rotation mark.
- Place the adapter in the direction corresponding to the following picture.

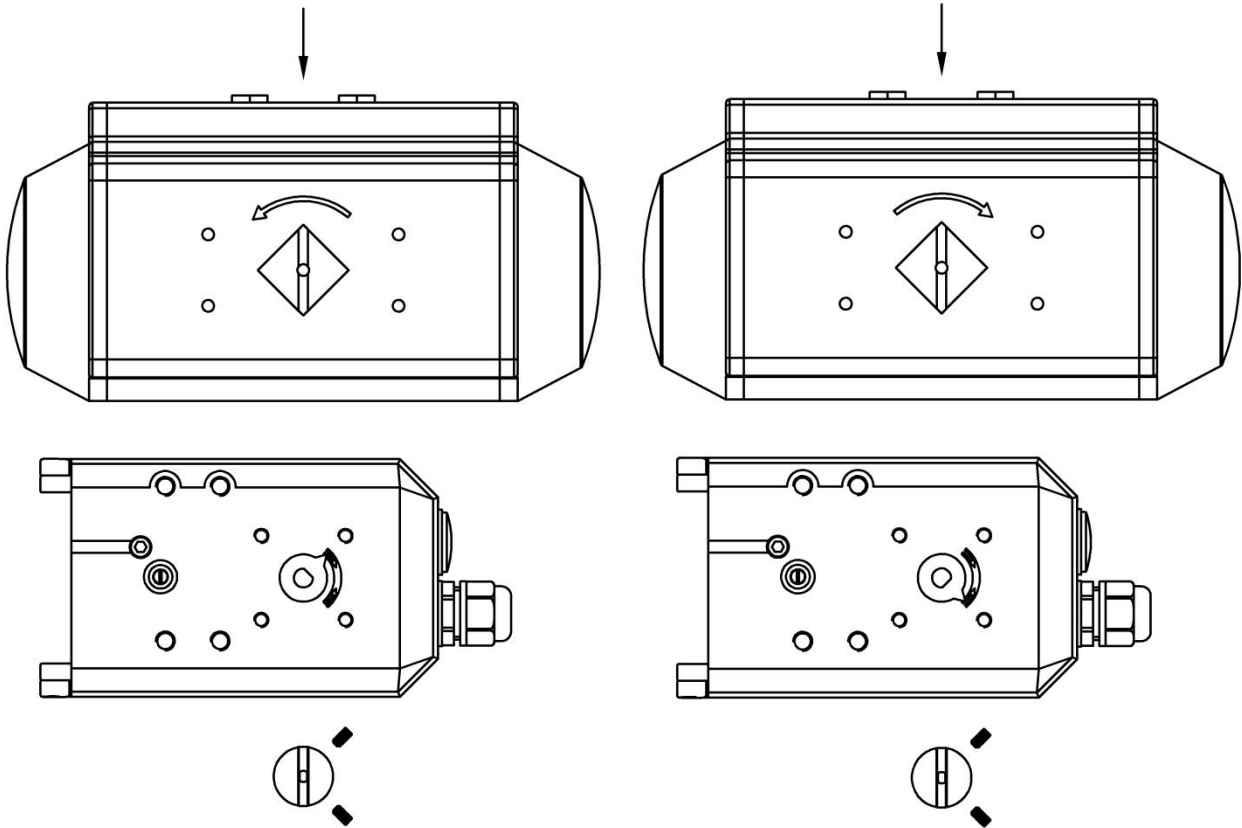

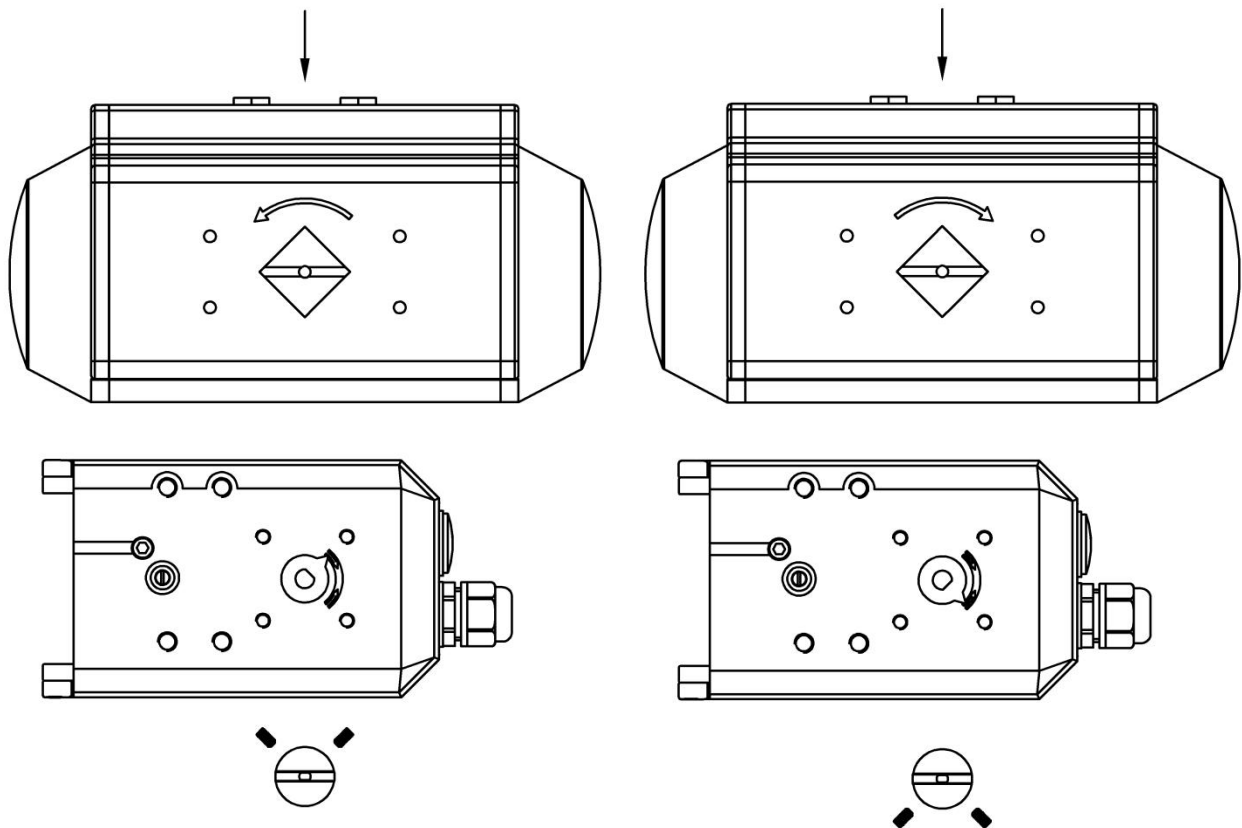

Figure 27. Four cases of installation matching

- Pay attention to the difference between the remote type and the normal type. For the installation of the remote type, please refer to the installation of the normal type.

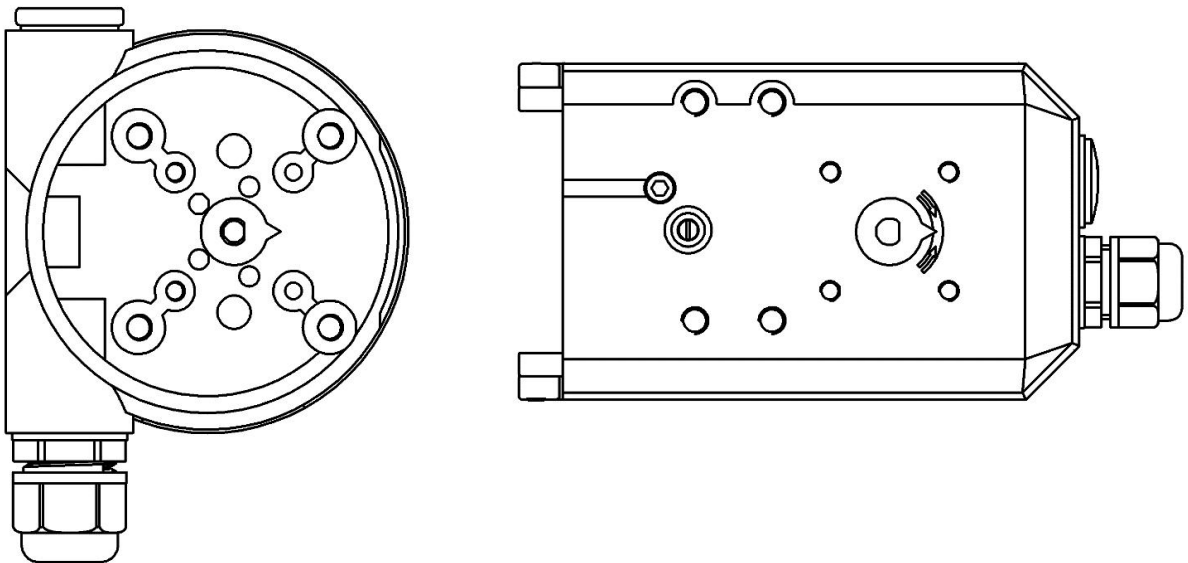

Figure 28. Comparison of the feedback axis pointers (remote type and normal type)

1. Confirm the initial position of the feedback axis of the positioner or the remote sensor (The operation is the same as the linear stroke installation in chapter 7.1).

2. Mount the adapter to the feedback axis of the positioner or the remote sensor.

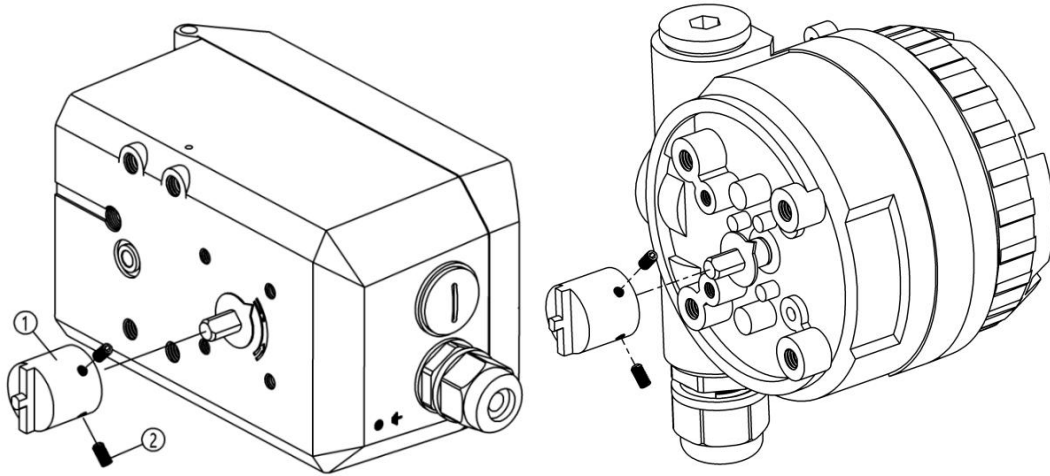

Figure 29. Adapter installation

Attach the adapter to the feedback axis in the direction in which it was prepared, and fix it with set screws②. Make sure one of the set screws is locked on the flat side of the feedback axis.

3. Mount rotary stroke mounting bracket to the bottom of the positioner.

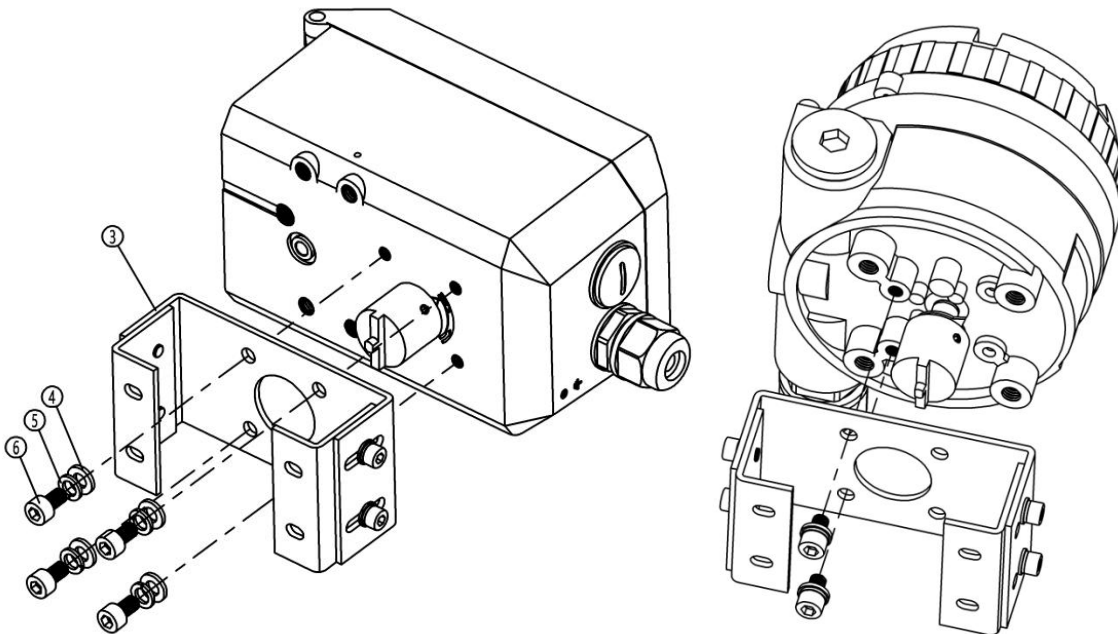

Figure 30. Rotary stroke mounting bracket installation

4. Mount the rotary stroke mounting bracket to the actuator.

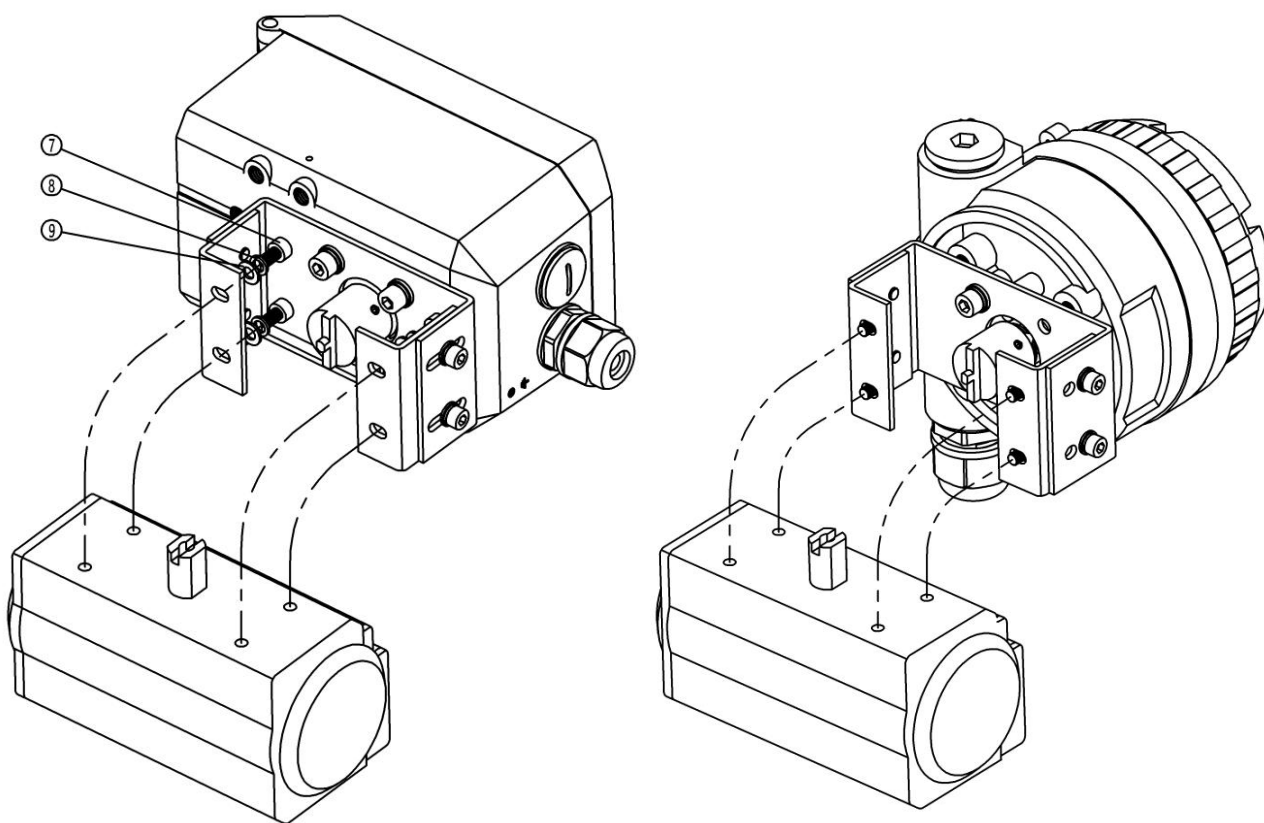

Figure 31. Installation with actuator

5. Overall schematic diagram.

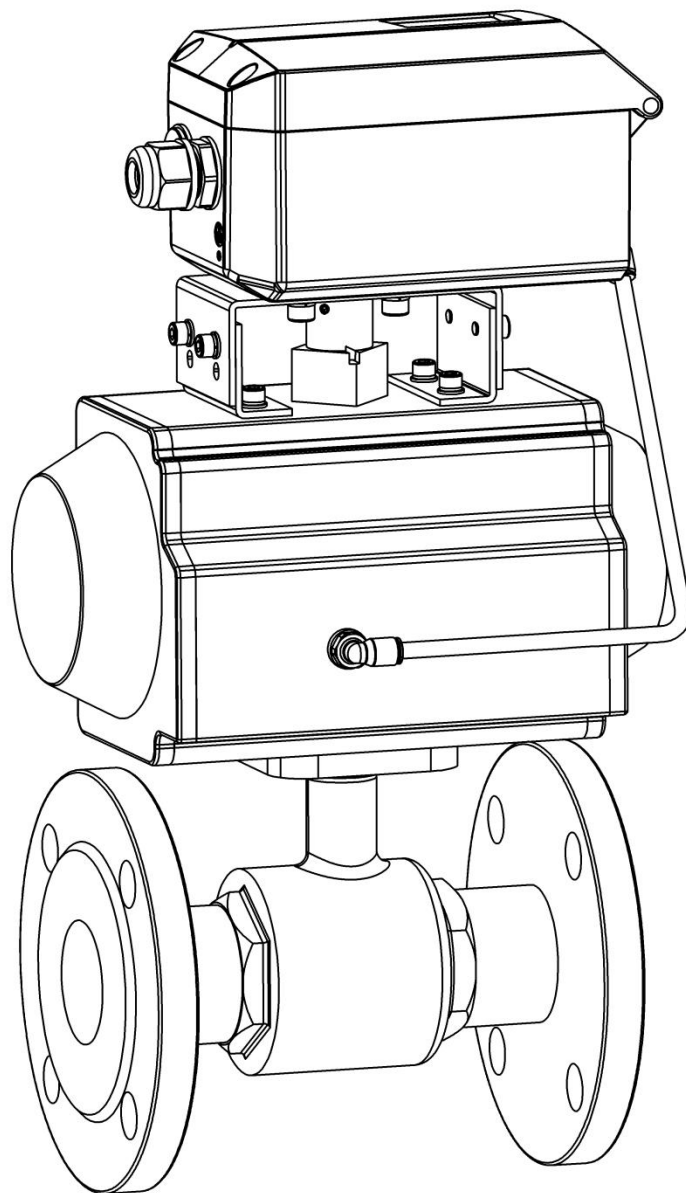

Figure 32. Rotary stroke for normal type

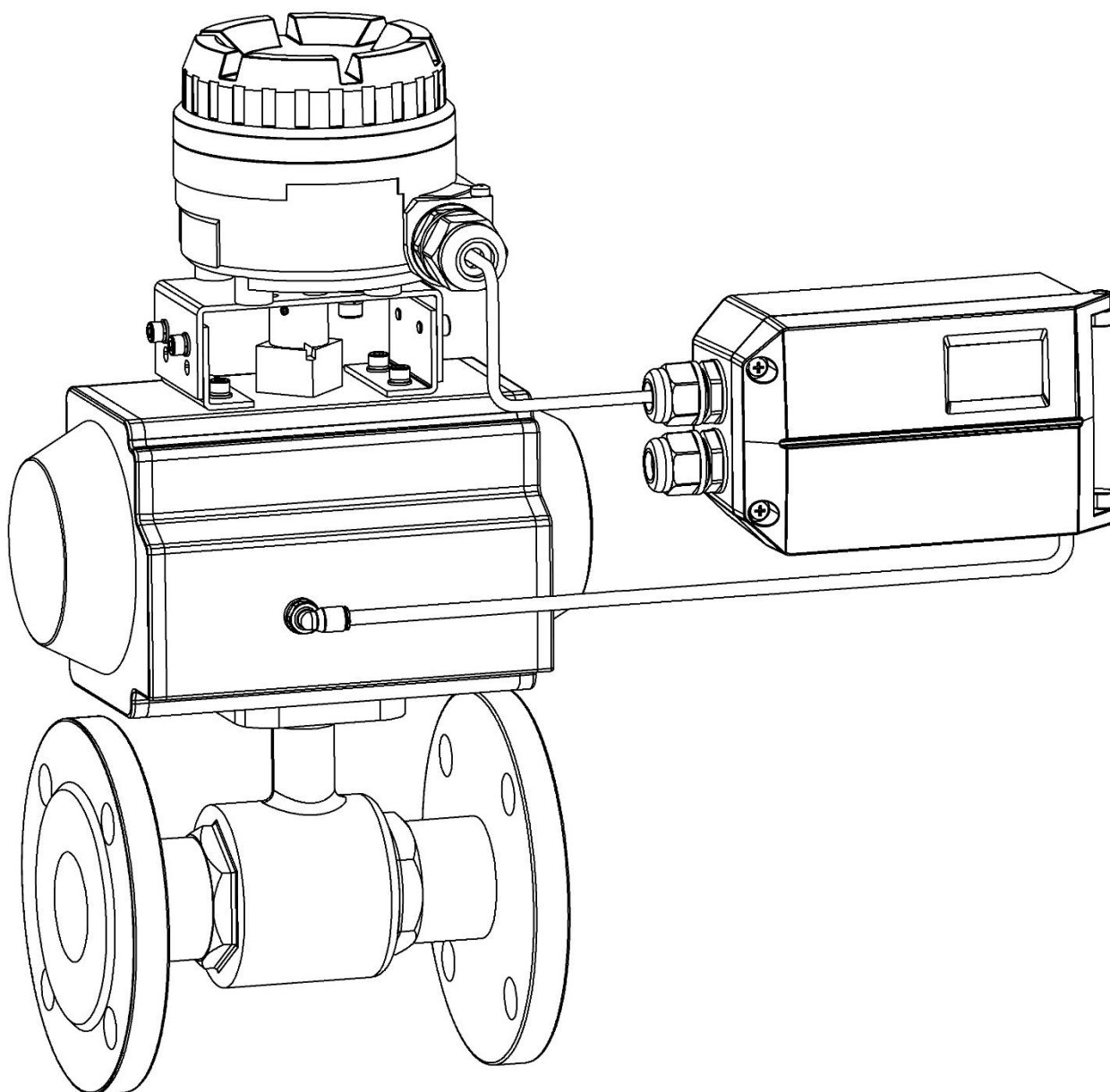

Figure 33. Rotary stroke for remote type

8. Operation





8.1. Interface description

User's operating interface includes one LCD screen and 4 buttons.

LCD display description

Position	Description
Top line	<ul style="list-style-type: none"> ● Display the percentage value of angle sensor in the initial interface (NOINI) or when running the initialization function. ● Display valve position percentage value in operating mode. ● Display parameter values in menu mode.
Bottom line	<ul style="list-style-type: none"> ● Display indication signs in uninitialized state. ● Display automatic or manual mode in operating mode. ● Display setpoint percentage value in operating mode. ● Display function options in menu mode. ● Display initialization step and error sign in initialization process.

Button operation description

Button	Description
	<ul style="list-style-type: none"> ● Enter the system menu. ● Switch automatic and manual mode in operating mode. ● Exit from the system menu to main interface ● Exit from submenu to previous menu.
	<ul style="list-style-type: none"> ● Open or close valve in the initial interface (NOINI). ● Decrease the valve position value in manual mode. If press and hold this button first, then press and hold  button, the valve position value will be reduced quickly. ● Select function options or parameters down and decrease parameter values in menu mode.
	<ul style="list-style-type: none"> ● Open or close valve in the initial interface (NOINI). ● Increase the valve position value in manual mode. If press and hold this button first, then press and hold  button, the valve position value will be increased

	<p>quickly.</p> <ul style="list-style-type: none"> ● Select function options or parameters up and increase parameter values in menu mode.
	<ul style="list-style-type: none"> ● Enter submenu, enable or confirm parameter modification in menu mode. ● Run initialization or reset to factory settings. ● Run initialization in initial interface (NOINI) or in operating mode.

8.2. Display and operation of main interface

Positioner is in the uninitialized state before initialization. When LCD displays the sign **NOINI**, interface displays percentage value of sensor in the top line. As shown in Figure 34.

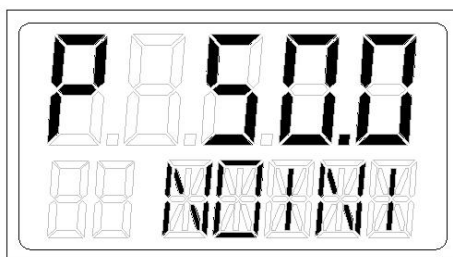







Figure 34. Uninitialized state interface

In this state, pressing   buttons can open and close valve. Open and close valve fully, and observe the percentage value of sensor displayed on the interface. Ensure that within the entire valve stroke range, the minimum sensor percentage value $\geq 5\%$, and the maximum sensor percentage value $\leq 95\%$. Otherwise, it is necessary to re-adjust the installation position to make the linear stroke feedback lever or the angle stroke adapter move within the effective range. In addition, the minimum and maximum percentage difference of the sensor is required to be greater than 16%.

If you want to take a shortcut of running automatic initialization (**INITA**), press and hold  button for approx. 3s to run it in the initial interface (**NOINI**) or in the operating mode. In the initialization process, pressing  button will exit. After exiting, if the initialization is completed before, system enters manual mode interface. Otherwise, system enters initial interface (**NOINI**). After the initialization is completed, press  button to exit. After exiting, the system enters the manual mode interface.

Operating mode includes automatic mode and manual mode.

In automatic mode, system adjusts the valve position automatically by collecting the external

4-20mA input signal.

In manual mode, valve position can be adjusted by pressing $\square\downarrow$ $\square\uparrow$ buttons manually.

In the main interface, the top line shows the valve position percentage value, and the bottom line shows the set-point percentage value. The last digit of the set-point percentage value is one decimal place. Sign **A** means automatic mode and sign **M** means manual mode. They can be switched by pressing $\square\hookrightarrow$ button. If the release time after pressing the $\square\hookrightarrow$ button is less than the operation time of entering the menu, operating mode can be switched. Otherwise, it will enter the menu. As shown in Figure 35.

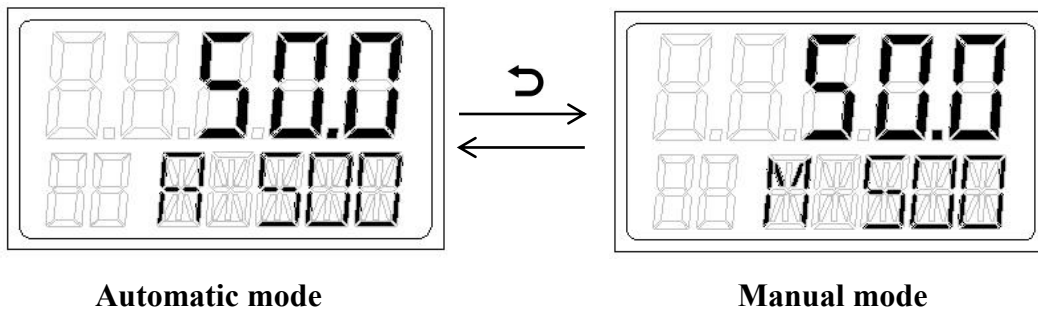

Figure 35. Operating mode interface

When the 4-20mA input signal $\leq 3.5\text{mA}$, the system considers the signal to be wrong. The **ERR** sign is displayed at the position of the set-point percentage value on the bottom line of the main interface. At this time, the valve position state is in the power off state of the product selection.

8.3. Menu and functions

8.3.1. Display and operation of menu

Press and hold $\square\hookrightarrow$ button for approx. 3s to enter the menu. The menu interface will display as Figure 36. Press $\square\hookrightarrow$ button, it will exit from menu interface to manual mode interface. The positioner with HART function cannot modify parameters or perform initialization operation through HART communication in the menu interface.

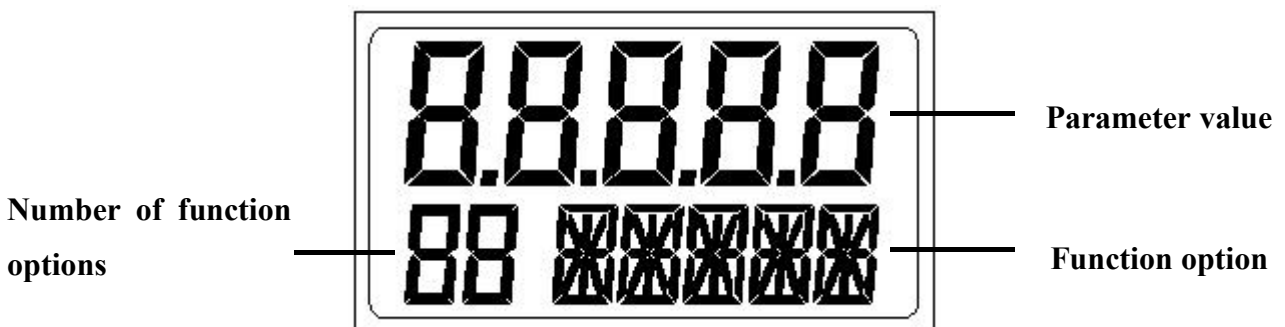

Figure 36. Menu interface



8.3.2. Functions description and operation

8.3.2.1. TYPE

TYPE is for setting the actuator type.

Options for setting parameter

Option	Description
Lin	Linear actuator with feedback lever A installed.
Turn	Rotary actuator.
FLin	Linear actuator with feedback lever B installed.

Select this function in the menu interface, press  button to start setting parameters, and the parameter will flash. Press   buttons to set parameter and press  button to confirm.

8.3.2.2. INITA

The function is auto initialization. It will automatically detect action direction, actual physical stroke of valve and control parameters.

Select this function in the menu interface, press and hold  button for approx. 3s to run, a scroll sign will appear in the lower left corner of LCD. Top line shows the percentage value of sensor and the step is showed in the bottom line. Sign **FINSH** will display on LCD after the auto initialization is completed.

For some reasons, the system will display an error message in the function option line during the auto initialization process and the auto initialization will be interrupted. Descriptions of error messages and solutions are showed in chapter 8.3.3.

8.3.2.3. INITM

The function is manual initialization. It is suitable for the user to confirm the valve stroke manually. The function requires the user to calibrate the valve stroke manually. Then it will automatically detect action direction and control parameters. The operation flow is as follows:

- 1) Select this function in the menu interface, press and hold  button for approx. 3s to run, a scroll sign will appear in the lower left corner of LCD. Top line shows the percentage value of

sensor and bottom line shows **END 1**.

- 2) When LCD displays **END 1**, press buttons to let the valve position move to the endpoint 1 of the manual calibrating stroke, and press button to confirm, then LCD will display **END 2**. Next, press buttons again to let the valve position move to the endpoint 2 of the manual calibrating stroke, and press button to confirm.
- 3) If there isn't error message after confirmation of **END 2**, the system will run the step 1 of initialization automatically and skip step 2 for stroke detection.

LCD will display **FINSH** when manual initialization is completed.

For some reasons, the system will display an error message in the function option line during the manual initialization process and the manual initialization will be interrupted. Descriptions of error messages and solutions are showed in chapter 8.3.3.

8.3.2.4. CAL

CAL is for calibrating 4-20mA input signal. When there is a big deviation between the set point value and the output value of the signal source, it can be calibrated by this function.

Sub-function options **4mA** and **20mA** are used for calibrating minimum and maximum value of 4-20mA input signal separately.

Select this function in the menu interface, press button to enter sub-function selection operation, and press buttons to select **4mA** or **20mA**, press button to start parameter setting, AD value of actual input signal flashes on LCD (Quantify the set signal numerically, ranging from 0 to 4095). For option **4mA**, set the front-end input signal to 4mA signal; for option **20mA**, set the front-end input signal to 20mA signal. For example, when the front-end input signal is 4mA, value 650 will flash on LCD. After the AD value on LCD is stable, press button to confirm it. The system will record current AD value (650) and it will be displayed on LCD. When the front-end input signal is 20mA, value 3270 will flash on LCD. After the AD value on LCD is stable, press button to confirm it. The system will record current AD value (3270) and it will be displayed on LCD. The calibration of the 4-20mA input signal is completed after the operation of option **4 mA** and option **20 mA**.

For example, if 4-20mA signal is set as 50%(12mA) in the field, while the actual signal value collected by positioner is 52% (12.32mA), it indicates that there is a deviation between the input signal and the signal actually collected by positioner. In this case, calibrate the input signal collected by the positioner by operating as above guidance to make it correspond to 4-20mA signal of the front-end of the system.

8.3.2.5. SDIR

SDIR function sets the corresponding relationship between 4-20mA set-point signal and set-point value.

Select this function in the menu interface, press button to start setting, and the parameter will flash. Press buttons to set parameter and press button to confirm.

Options for setting parameter

Option	Description
riSE	4 mA → 0%, 20 mA → 100%.
FALL	4 mA → 100%, 20 mA → 0%.

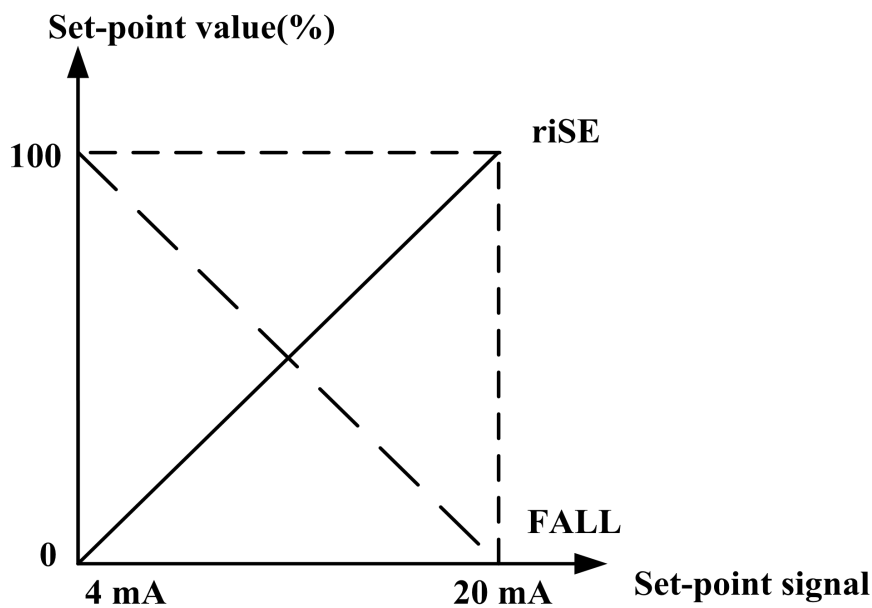

Figure 37. SDIR

8.3.2.6. CHAR

The characteristic curve is the relationship between set-point value and valve stroke.

In the actual control system, it is usually required to make the controlled variable have specific control characteristics (such as linearity). The user can choose and set the corresponding characteristic curve to achieve the control requirements.

The function is to determine the relationship between position set-point value and valve stroke.

Select this function in the menu interface, press button to start setting, and the parameter will

flash. Press buttons to set parameter and press button to confirm.

Option for CHAR

Option	Description
Lin	1:1 linear transfer relationship between position set-point value and valve stroke.
1-25	1:25 equal percentage transfer relationship between position set-point value and valve stroke.
1-33	1:33 equal percentage transfer relationship between position set-point value and valve stroke.
1-50	1:50 equal percentage transfer relationship between position set-point value and valve stroke.
n1-25	1:25 inverse equal percentage transfer relationship between position set-point value and valve stroke.
n1-33	1:33 inverse equal percentage transfer relationship between position set-point value and valve stroke.
n1-50	1:50 inverse equal percentage transfer relationship between position set-point value and valve stroke.
FrEE	Freely programmable transfer relationship between position set-point value and valve stroke for user. The position set-point value scale ranging from 0-100% is divided uniformly into 21 nodes. A freely programmable valve stroke ranging from 0-100% is assigned to each node. User can set value by selecting option FR 0 , FR 5 , ..., FR 100 .

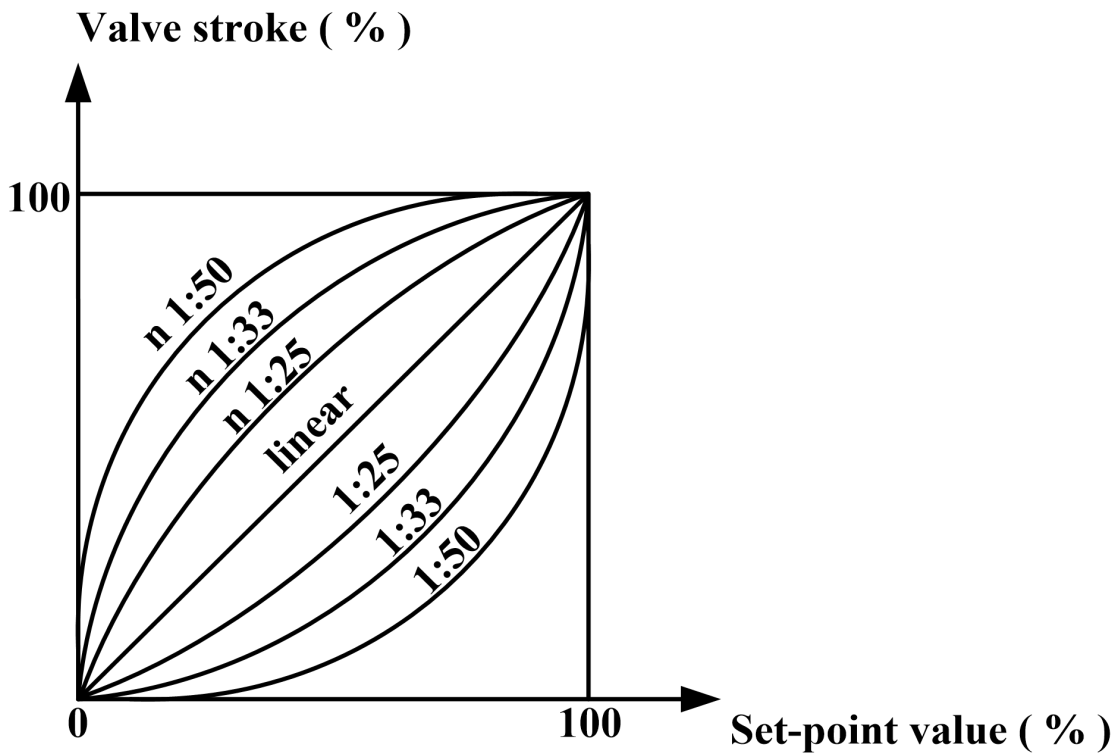

Figure 38. CHAR

8.3.2.7. FREE

Set value of **FrEE** characteristic curve in **CHAR** function option.

Sub-function options of **FREE** are **FR 0**, **FR 5**, ..., **FR 100**, 21 set points in total.

Select this function in the menu interface, press button to enter sub-function option, and select set point by pressing buttons, then press button to start setting parameter, and the parameter will flash. Press buttons to set parameter, it can be modified quickly by pressing or button continuously, finally press button to confirm.

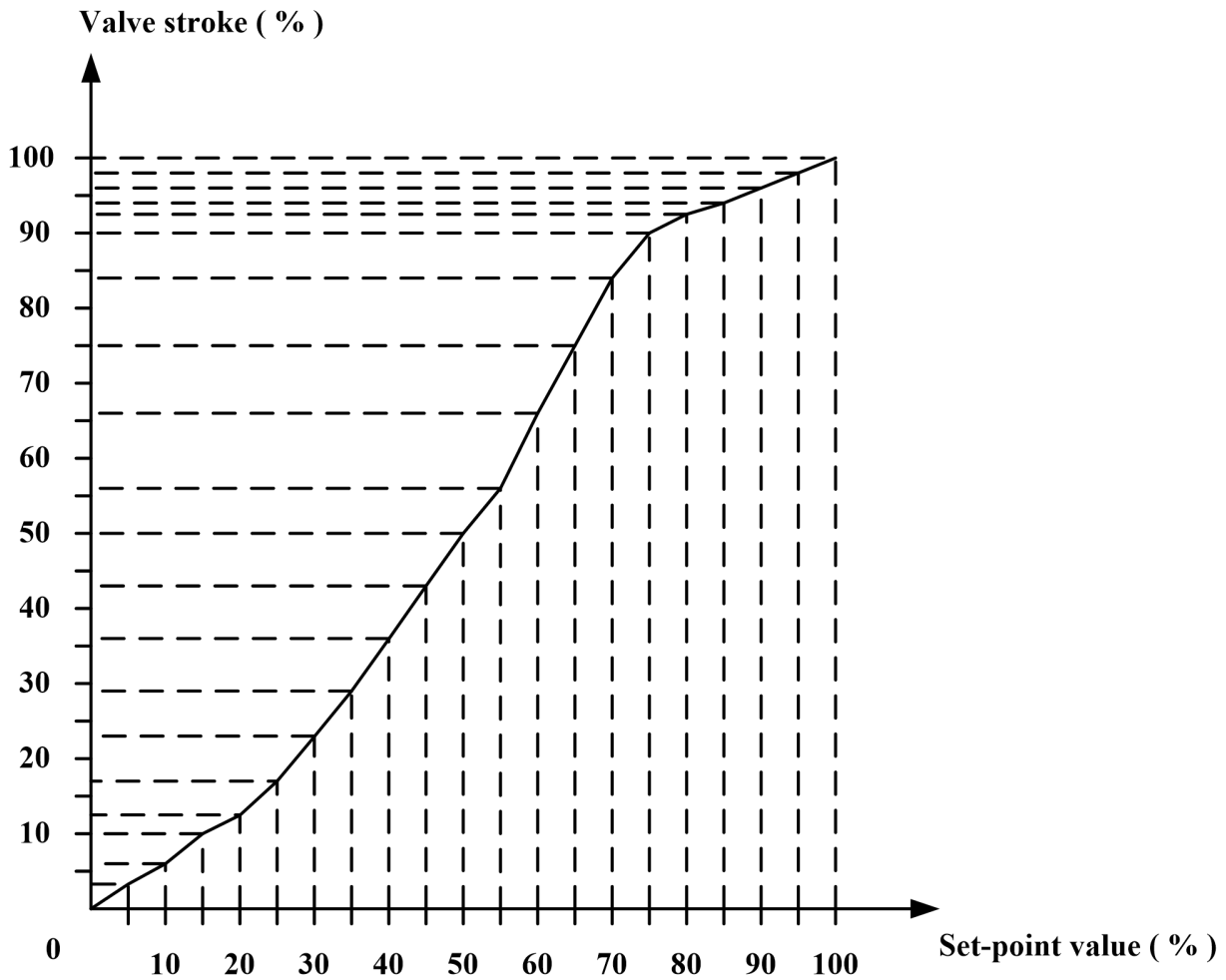

Figure 39. FREE

8.3.2.8. DB

Set Dead band zone of positioner.

The system does not adjust the valve stroke when the gap between the stroke value and the position set-point value is not bigger than the dead band value.

For example, positioner will not do adjustment if the actual valve position is not in the range of $50 \pm 1\%$ when the position set-point value is 50% and dead band value is 1%. If it's not in the range of $50 \pm 1\%$, the piezoelectric module will be driven to adjust valve position until it's in the range of $50 \pm 1\%$.

It's recommended to increase the dead band value if the valve position oscillates. The smaller the dead band sets, the higher control accuracy gets.

Select this function in the menu interface, press button to start setting, and the parameter will flash. Press buttons to set parameter, it can be modified quickly by pressing or

button continuously, finally press \odot button to confirm.

8.3.2.9. LIM

This function limits the automatic adjustment range in the whole valve physical stroke.

The LIM sub-function options L MIN and L MAX of set the minimum and maximum limits of the stroke respectively.

Select this function in the menu interface, press \odot button to enter sub-function option, press ∇ \blacktriangle buttons to select option L MIN or L MAX, press \odot button to start setting, and the parameter will flash. Press ∇ \blacktriangle buttons to set parameter, it can be modified quickly by pressing ∇ or \blacktriangle button continuously, finally press \odot button to confirm.

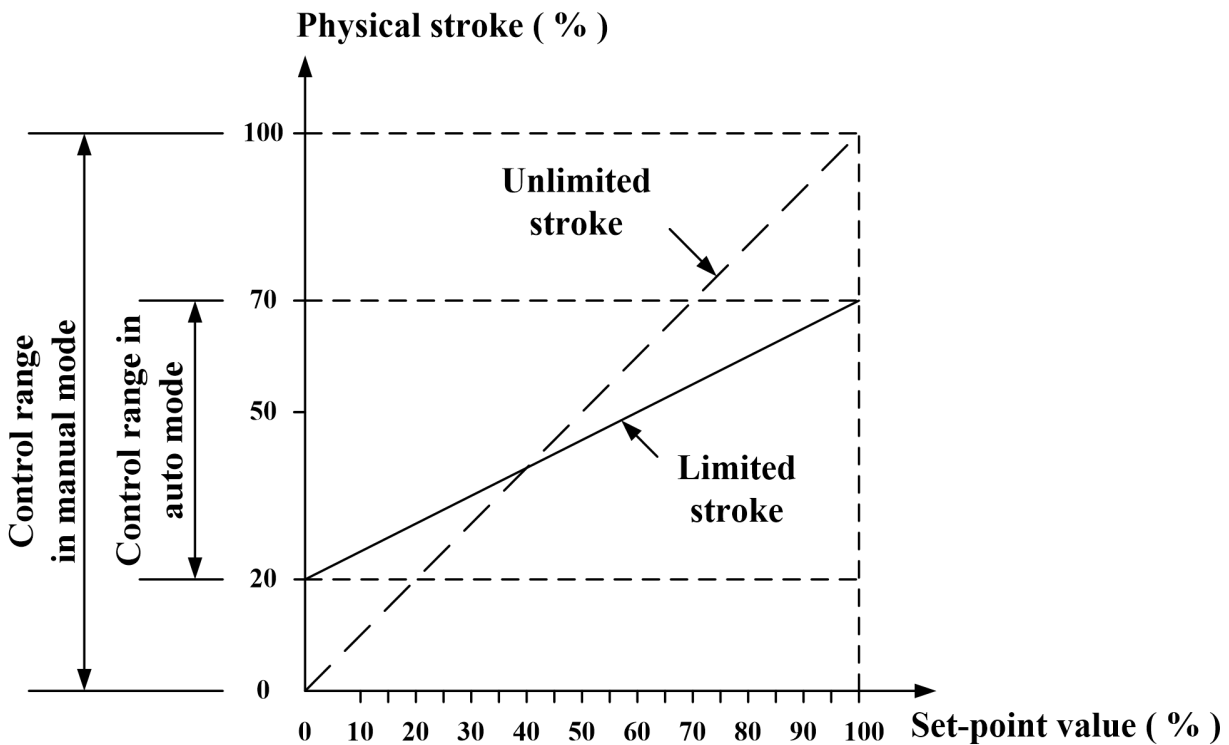

Figure 40. LIM

8.3.2.10. YDIR

This function is used to set the direction of the position display and position feedback signal.

Select this function in the menu interface, press \odot button to start setting, and the parameter will flash. Press ∇ \blacktriangle buttons to set parameter and press \odot button to confirm.

Options for setting parameter

Option	Description
riSE	The position display and the value of the position feedback signal correspond to the stroke detected by the positioner.
FALL	The position display and the value of the position feedback signal are opposite to the stroke detected by the positioner.

8.3.2.11.CUT

This function is used for the positioner to fully close or open the valve in automatic mode. When the function is enabled, sign **CU** displays in the left bottom in main interface.

The **CUT** sub-function options **C MIN** and **C MAX** respectively set the minimum and maximum values.

Select this function in the menu interface, press button to enter sub-function option, press buttons to select option **C MIN** or **C MAX**, press button to start setting, and the parameter will flash. Press buttons to set parameter, it can be modified quickly by pressing or button continuously, finally press button to confirm.

When **C MIN** value is 0, full closing is disabled. When **C MAX** value is 100, full opening is disabled.

When valve is in the positioning state, if the set point value \leq **C MIN**, the valve will be fully close; if set point value \geq **C MAX**, it will be fully open.

When the set point value $>$ **C MIN** + 1%, valve will disengage from the full closing state.

When the set point value $<$ **C MAX** - 1%, valve will disengage from the full opening state.

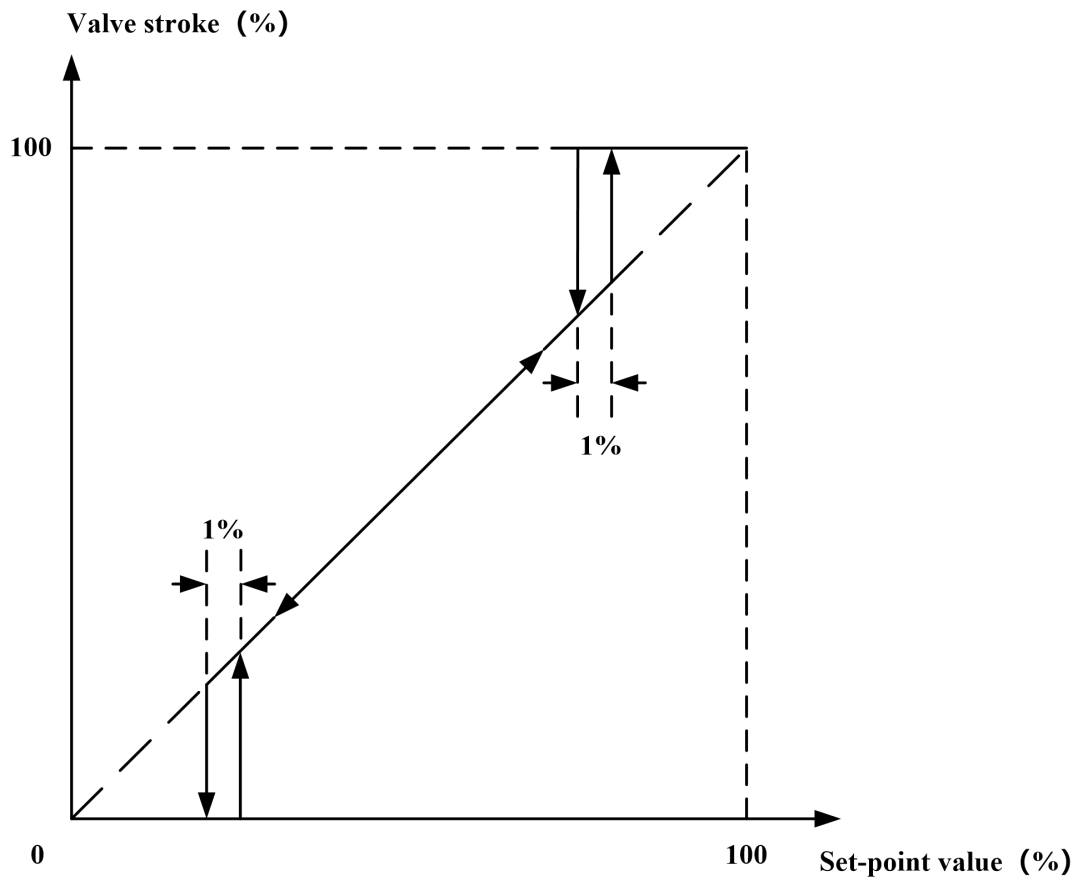

Figure 41. CUT

8.3.2.12.POS

This function is used to set the standard of position display and feedback signal output.

Select this function in the menu interface, press button to start setting, and the parameter will flash. Press buttons to set parameter and press button to confirm.

Options for setting parameter

Option	Description
FS	The position display and feedback signal output correspond to 0-100% of mechanical stroke. The set-point value is displayed as the actual valve position set value. Not affected by the L MIN and L MAX parameters.
LS	The position display and feedback signal output take the form of 0-100% to represent the range between the L MIN and L MAX parameters. The set-point value is displayed with this standard.

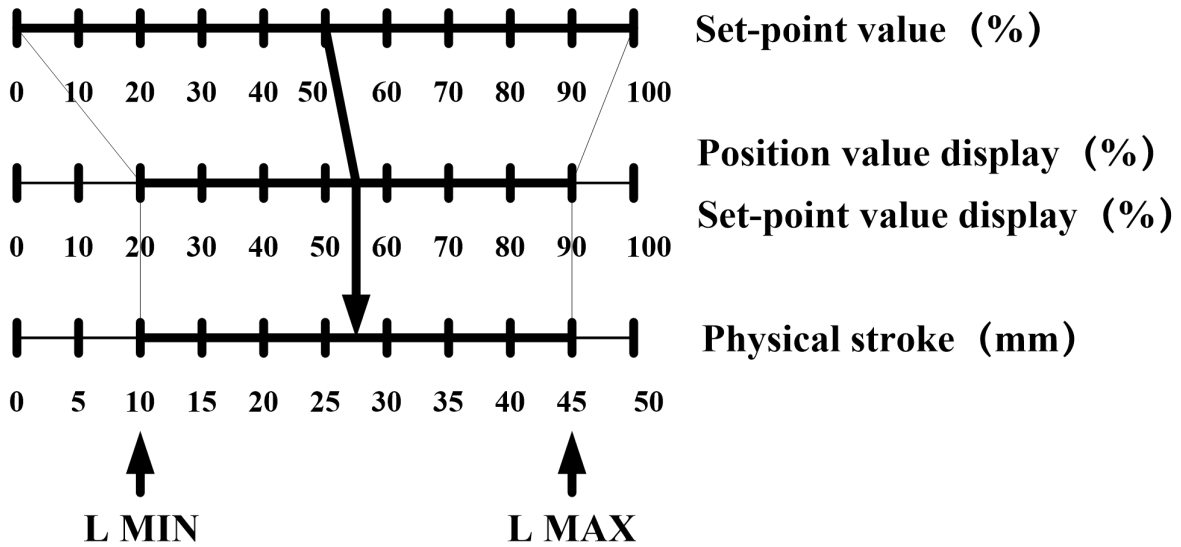

Figure 42. Example: $POS = FS$, $L MIN = 20\%$, $L MAX = 90\%$

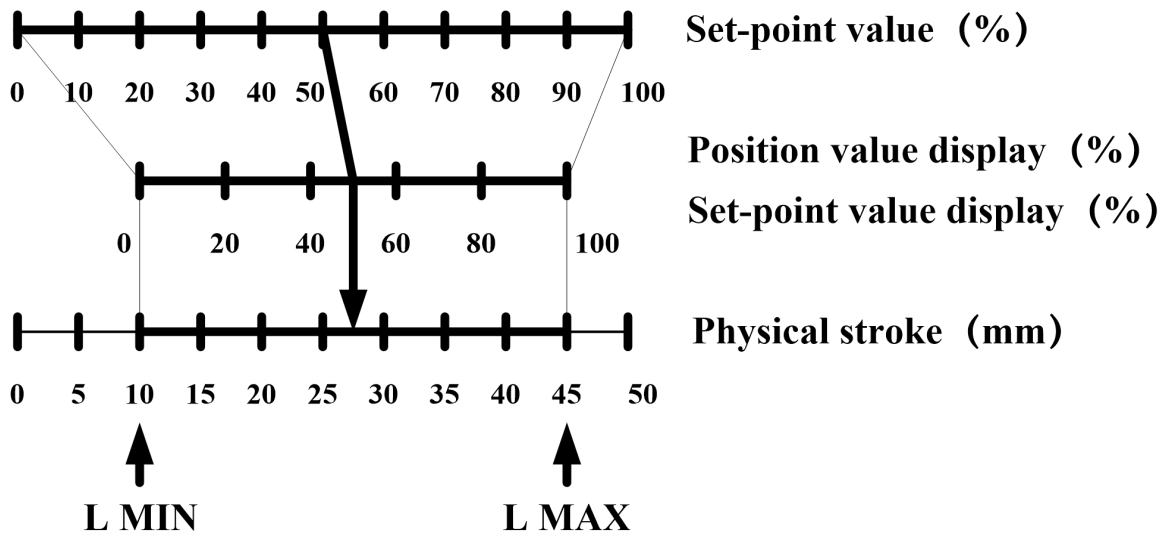



Figure 43. Example: $POS = LS$, $L MIN = 20\%$, $L MAX = 90\%$





8.3.2.13.FACT

All setting parameters in the menu reset to factory default values.

Select this function in the menu interface, press and hold  button for approx. 3s to reset to factory setting. Then the system is in an uninitialized state and the LCD displays **FINSH**.

8.3.2.14.WP

This function is a parameter write protection function. The parameter **oFF** is write protection disabled, and the parameter **on** is write protection enabled.

Select this function in the menu interface, press  button to start setting, and the parameter will flash. Press   buttons to set parameter and press  button to confirm. When the write protection is enabled, menu options 1-13 are not operational.



8.3.2.15.ACT

This function is used to set acting mode. It is used for the manufacturer. It is not recommended for users to operate this option without special circumstances.

8.3.2.16.REF

Calibrate the reference point of the linear feedback lever. It is used for the manufacturer. It is not recommended for users to operate this option without special circumstances.

8.3.3. Error message during initialization

Sign	Meaning	Possible reasons	Solutions
ERR 1	Actuator action error	<ul style="list-style-type: none"> ● No air pressure or insufficient air pressure ● There is a leakage from actuator or positioner. 	<ul style="list-style-type: none"> ● Check air source and its pressure to make sure that it meets the requirement ● Eliminate air leakage
ERR 2	Rotation angle of actuator feedback lever or rotating shaft is error.	<ul style="list-style-type: none"> ● Positioner is not installed correctly. As a result, the rotation angle of actuator feedback lever or rotating shaft doesn't meet the installation requirements. ● When running the manual initialization, 	<ul style="list-style-type: none"> ● In the initial interface (NOINI), adjust the installation position by the angle sensor percentage value displayed on LCD, make sure the minimum and maximum percentage difference of the angle sensor rotation is greater than 16%. ● If it's in the manual initialization operation process, press  

		the difference from END 1 to END 2 doesn't meet the installation requirements.	buttons to re-calibrate END 1 and END 2 , make sure that difference percentage value between two endpoints of sensor is bigger than 16%.
ERR 3	error minimum stroke value of sensor	The positioner is not installed correctly.	In the initial interface (NOINI), adjust the installation position by the angle sensor percentage value displayed on LCD. Make sure that minimum percentage value of sensor is bigger than 2%.
ERR 4	Error maximum stroke value of sensor	The positioner is not installed correctly.	In the initial interface (NOINI), adjust the installation position by the angle sensor percentage value displayed on LCD. Make sure that maximum percentage value of sensor is smaller than 98%.

8.3.4. Tips of menu option or function cannot access

When setting menu option parameters or running initialization, the following signs may appear to indicate that they cannot be accessed. See the table below for specific instructions.

Sign	Meaning
P1	Write protection is enabled.
P2	The reference point of the linear feedback lever is not calibrated, and the initialization operation of the linear actuator cannot be performed.

8.3.5. Menu function options summary description

Options	Functions	Parameter value	Factory settings
1 TYPE	Actuator type setting	Lin Turn FLin	Lin

2 INITA	Auto initialization		
3 INITM	Manual initialization		
4 CAL→4 mA	Calibrate 4mA set point signal	Current signal AD value	765
4 CAL→20 mA	Calibrate 20mA set point signal	Current signal AD value	3823
5 SDIR	Set the direction of set point signal	riSE FALL	riSE
6 CHAR	Select characteristic curve	Lin 1:25 1:33 1:50 n1:25 n1:33 n1:50 FrEE	Lin
7 FREE→FR 0, FR 5...FR 100	Custom parameters settings	0.0% – 100.0%	0.0% 5.0% etc. to 100.0%
8 DB	Set dead band	0.2 – 10.0%	1.0%
9 LIM→L MIN	Set minimum value for stroke range limit function	0.0% – 100.0%	0.0%
9 LIM→L MAX	Set maximum value for stroke range limit function	0.0% – 100.0%	100.0%
10 YDIR	Set position display and feedback direction	riSE FALL	riSE
11 CUT→C MIN	Set minimum value for tight cut function	0.0% – 100.0%	1.0%
11 CUT→C MAX	Set maximum value for tight cut function	0.0% – 100.0%	100.0%
12 POS	Set Position display and feedback signal output standard	FS LS	FS
13 FACT	Reset to factory setting		

14 WP	Write protection	oFF on	oFF
15 ACT	Acting mode selection		
16 REF	Calibrate the reference point of the linear feedback lever		

8.4. Feedback signal

The positioner can be optionally equipped with a 4-20 mA feedback signal. It indicates the percentage value of the valve position.

The feedback signal will stop updating after entering the menu.

8.5. Adjust air flow

1. Remove the circuit board protective cover.

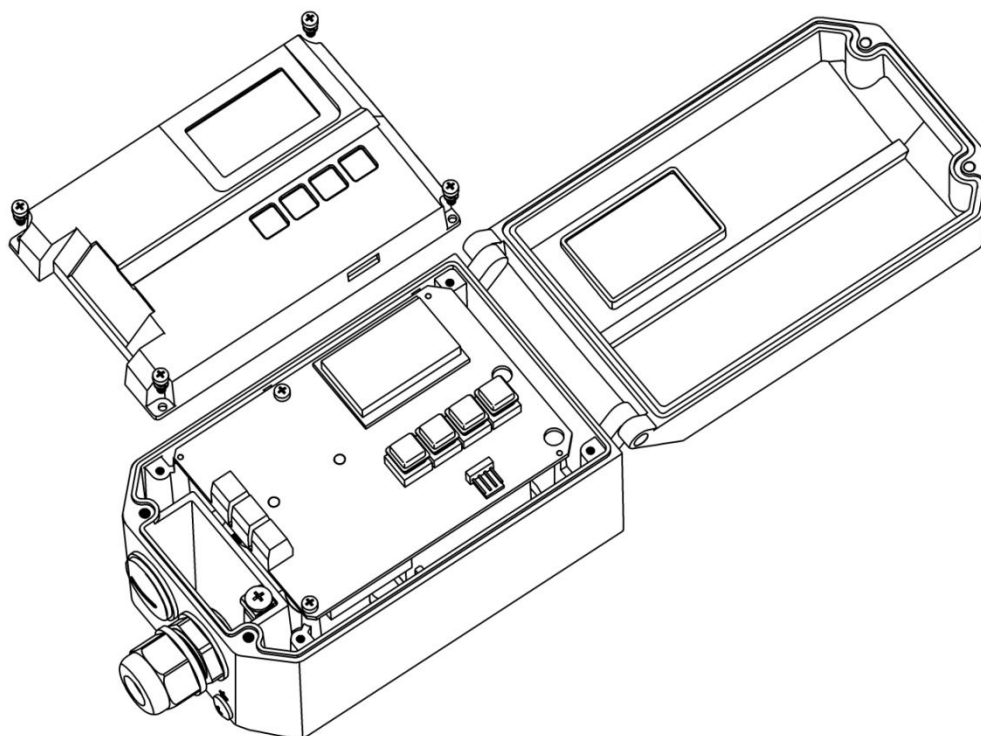

Figure 44. Remove the circuit board protective cover

NOTE: Must install or remove the circuit board protective cover when the device is powered off.

2. Adjust restrictors

- Restrictors Y1 ① and Y2 ② can reduce air output to increase the stability of positioning for small volume actuators.
- Turning the Restrictors in clockwise direction with a flat blade screwdriver can reduce the air flow until it is cut off.
- When adjusting restrictors, it is recommended to close them first and then open them again slowly.
- Make sure two restrictors are turned to the similar position for the double-acting actuator.

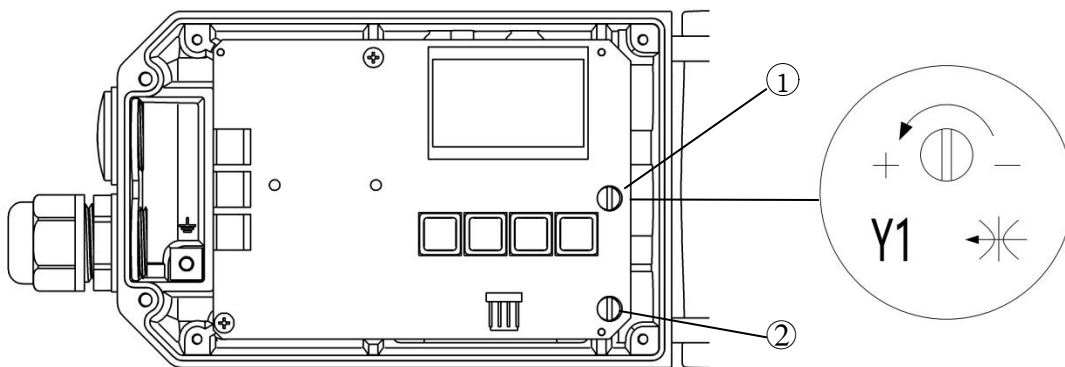

Figure 45. Air flow adjustment

- ① Restrictors Y1
- ② Restrictors Y2, only for double-acting actuator.

9. Trouble shooting

Contents	Possible reasons	Solutions
LCD has no display	Error electrical connections.	Check the electrical connections
	No current output from current source	Make sure that there is current output from the current source.
	The current source is out of specified range	Use the proper current source.
	Others	Consult with manufacturer.
There is no air output in OUT1 or OUT2 (Without any action)	The air supply pressure is abnormal	Check the setting of the air pressure reducing valve.
	No input current	Make sure the input current is proper. (4-20mA DC)
	Accessory pipe leakage	Check the pipe and connection to make sure that there isn't any leakage.
	Others	Consult with manufacturer.
Bad accuracy (Linear and hysteresis phenomena)	The air supply pressure changes	Check whether there is any abnormality of the air supply pressure reducing valve
	The mounting bolts loose	Make sure the mounting bolts are tightened.
	The connection place between the positioner and the actuator has gap	Check the connection.
	Set-point value deviation	Adjust the current output signal.
		Calibrate the set-point signal.
Others	Consult with manufacturer.	

10. Warranty terms

1. If the product is found to have quality problems which are confirmed by our company staff, customers have after-sale services for product maintenance or free replacement in the warranty period. Service response time is 24 hours (excluding non-working days).
2. The warranty period of the product is based on the company's latest warranty policy, which is no less than 12 months after the sale.
3. The following situations for repaired product do not belong to the warranty range:
 - (1) The date is not in the warranty period.
 - (2) The product is disassembled without authorization and permit by the product company.
 - (3) The damage causes from the operation which is not according to the product instruction manual or other human factors. Including but not limited to:
 - 1> The product surface has collision scars.
 - 2> Error wiring or error power supply makes the product damaged.
 - 3> Parts and accessories are lost.
 - 4> The product is damaged due to the oil entering the product without oil separator or filter pressure reducer being installed.
 - 5> Error using the waterproof electrical connectors makes the product damaged.
 - (4) Force majeure (natural disasters) causes product failure or damage.
4. According to the actual situation, the product company offers the free or fee-based maintenance services outside the warranty range.
5. The terms become effective since the two sides signed a supply contract.

V251127

本说明书内容变更，恕不另行通知。

相关技术更新本公司保留最终解释权。

The changed contents of this manual are not noticed.

The Company reserves the final interpretation for related technical updating

附件

智能阀门定位器气源要求

全系列产品

按照技术要求，全系列的智能阀门定位器气源要求为 3 级，提供符合气源要求的压缩空气，可以确保定位器的正常使用。

露点 3 级：露点为 -20°C 。（若定位器实际工作环境温度低于 -20°C ，则使用的压缩空气露点需相应低于定位器实际工作环境温度 -10°C ）

固体颗粒大小和密度 3 级： $5.0\text{mg}/\text{m}^3$ （对应粒径为 $5.0\mu\text{m}$ ），不允许有粒径大于 $5.0\mu\text{m}$ 的颗粒进入。

含油量 3 级： $1.0\text{mg}/\text{m}^3$ ，每单位立方米的空气累积油含量不超过 1.0mg 。

流程示例



图 1. 流程图

①在主管路中配备压缩空气干燥机，过滤掉压缩空气中产生的大部分水分，过滤后的压力露点可达到 -20°C ；

②选择任意与图 2 一致的调压过滤器组合安装在定位器管路的前端，安装时需过滤减压阀（空

气过滤器) 在前, 油雾分离器在后, 要求过滤器过滤粒径在 5.0um 以上的颗粒, 最高残余油含量 $\leq 1.0\text{mg}/\text{m}^3$ 。

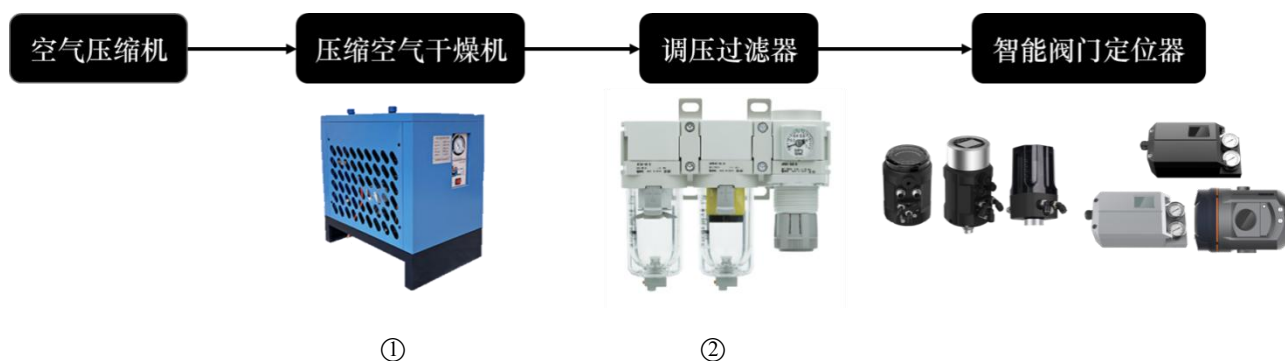

图 2. 调压过滤器组合

过滤器选型推荐

选型组合	<p>空气过滤器 + 油雾分离器 + 减压阀</p> <p>AF AFM AR</p>	<p>过滤减压阀 + 油雾分离器</p> <p>AW AFM</p>
	<p>AC 30 C- [] 03 DG - [] - [] - A</p> <p>① ② ③ ④ ⑤ ⑥</p>	<p>AC 30 D- [] 03 DG - [] - [] - A</p> <p>① ② ③ ④ ⑤ ⑥</p>

选型编号	SMC AC20C-02G-A	SMC AC20D-02G-A	SMC AC30D-02G-A
		入口侧压缩空气质量略低于定位器使用要求时	入口侧压缩空气质量符合定位器使用要求时
基础参数	流体：空气 环境温度及使用温度：-5~60°C（未冻结） 耐压：1.5MPa 使用压力范围：0.05~1.0MPa 设定压力范围：0.05~0.7MPa 过滤精度：AW:5um、AFM：0.3um（捕集效率 99.9%） 杯体材质：聚碳酸酯 结构：溢流型		
选型参数	①主体尺寸：20 额定流量：200L/min 杯体保护罩：标准（钢带） 质量：0.39kg ②螺纹种类（无记号）：Rc ③接口管径 02：1/4 ④无记号：手动排水器 压力表 G：圆形压力表（带限位指示器） ⑤无记号：无附件 ⑥无记号：无特殊选择	①主体尺寸：20 额定流量： 150L/min 杯体保护罩：标准 （钢带） 质量：0.33kg	①主体尺寸：30 额定流量： 330L/min 杯体保护罩：标准 装备（聚碳酸酯） 质量：0.66kg
		②螺纹种类（无记号）：Rc ③接口管径 02：1/4 ④无记号：手动排水器 压力表 G：圆形压力表（带限位指示器） ⑤无记号：无附件 ⑥无记号：无特殊选择	
1 系列定位器*	●	●	/

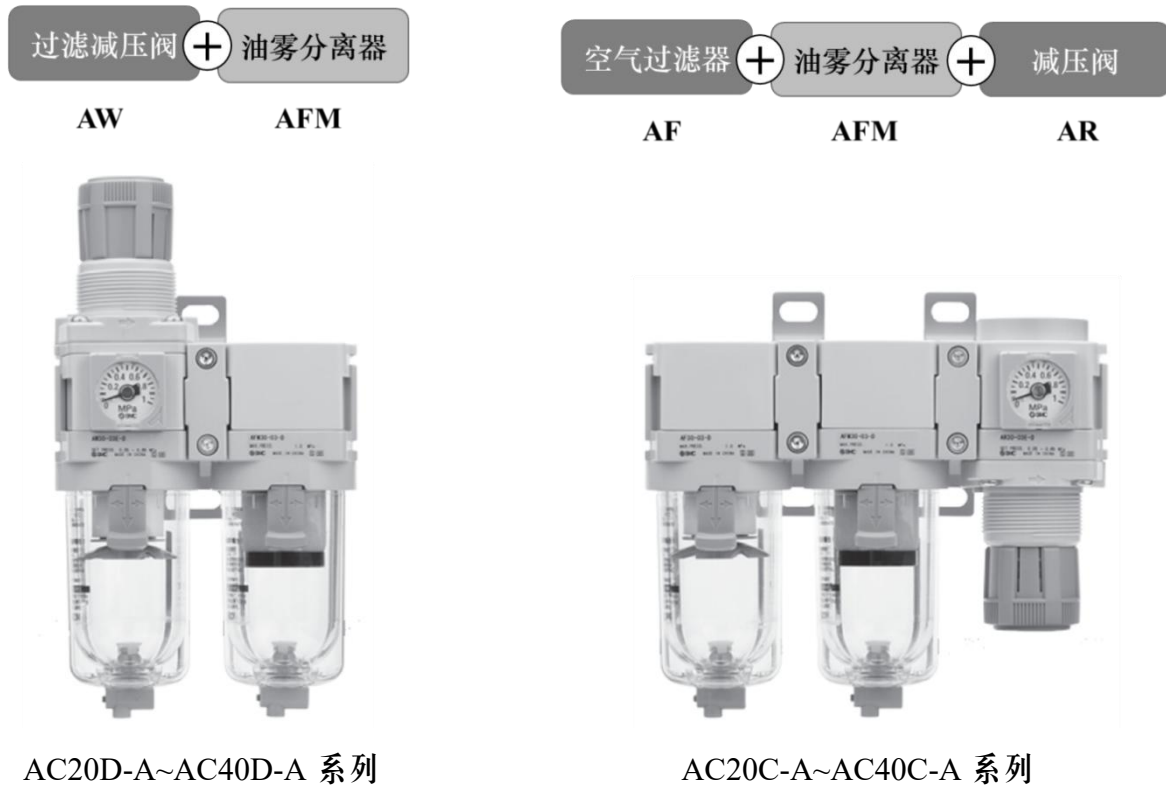
IP 系列定位器*	●	/	●
-----------	---	---	---

*●为推荐的选择

注：过滤器处理空气额定流量需大于定位器的最大工作流量，在同一串联管路上存在多台定位器时则最大工作流量需相加计算（1系列最大流量 1500、1600：Q1-17L/min；Q2-95L/min；1880S：17L/min IP系列最大流量 IP5500: 155 L/min；IP6000/IP6500:187 L/min；IP6000d: 150 L/min 以上数据均为 0.6MPa 下测量所得）。

注意事项

1. 应视工况要求选择不同性能的调压过滤器，避免因工作环境的高温、低温、高压、腐蚀等原因导致调压过滤器失效,详见末尾附录选型表。
2. 定期巡查过滤器的使用情况，若使用频繁的工况应提高巡查次数，避免因过滤器滤芯堵塞导致的故障问题（故障举例：①过滤失效，导致定位器进入异物，致使定位器故障；②滤芯堵塞，导致气源供应异常，定位器无法正常工作等）。
3. 采用自动排水功能的调压过滤器需要避免排水孔的堵塞，定期巡查可避免过滤器故障导致滤杯内大量积水。手动排水的应视工况下过滤器的积水速率，定时人工排水。
4. 按照调压过滤器的使用说明，定期维护或更换不合格的产品，可避免不必要的故障出现。